



Ratings		25 ÷ 800 VA			
Voltage range	Primary	230 / 400 / 460 V			
	Secondary	6 / 12 V	12 / 24 V	24 / 48 V	115 / 230 V

Voltage selection by means of metal connection bridges, offering the full rated power at any selected combination of input and output voltages.



Applications



- **Control Transformer:** Transformer able to supply a high instantaneous power without voltage drop at the output. Very suitable for interlocking contactors, relays and electro valves, as well as adaptation of the mains voltage to the necessary supply voltage of the loads.



- **Isolation Transformer:** Transformer with secondary voltage > 50 V, with double or reinforced isolation between primary and secondary. Its construction provides an excellent degree of attenuation of electrical distortions. Recommended for:
 - Electronic equipment, PLC's and automation systems.
 - Auxiliary elements in electrical panels.
 - Linear and switching power supplies.

Eliminates the risk of human accidents in case of unipolar contacts.



- **Safety Transformer:** Transformer with secondary voltage < 50 V, with double or reinforced isolation between primary and secondary. Eliminates any risk of human accidents in case of unipolar or bipolar contacts.

Standards

- IEC / EN / UNE-EN 61558-2-2 Control transformer
- IEC / EN / UNE-EN 61558-2-4 Isolating transformer
- IEC / EN / UNE-EN 61558-2-6 Safety transformer
- UL 506 Control, isolating and safety transformer

Characteristics

- Frequency 50 - 60 Hz
- Protection degree IP - 20
- Ambient temperature (ta) + 25 ° C (IEC 61558)
- Relative humidity (without condensation) < 95 %
- Safety class Class I or Class II (selectable)
- Installation location Indoor
- Duty Continuous
- Test voltage (Dielectric Strength):
 - between Primary and Secondary 4,6 KV
 - between Primary and Earth 3,2 KV
 - between Secondary and Earth 2,5 KV
- Voltage drop at nominal rating < 5 %
- Eternal cover Polymer of latest technology, non-flammable V-0 according to UL94
- Isolations Class B-130° C (IEC 61558)
- Windings Copper HC-200° C (double enamelled)
- Cooling (AN) Natural Aire
- Terminals Screws with self-lifting supporting washers
- Earth terminal Screws with self-lifting supporting washers
- Operation indicator Led

- **Fast mounting system:** enclosure suitable for mounting on DIN Rail 35 x 7,5 mm (EN 50022) up to 250 VA for easy mounting in electrical panels and switchboards.
- **Separation of connections:** by separations of technical polymer.
- **Protection of connection terminals:** by means of polycarbonate cover (V-2 according to UL94) avoiding accidental electrical contacts.

Dimensions and weights

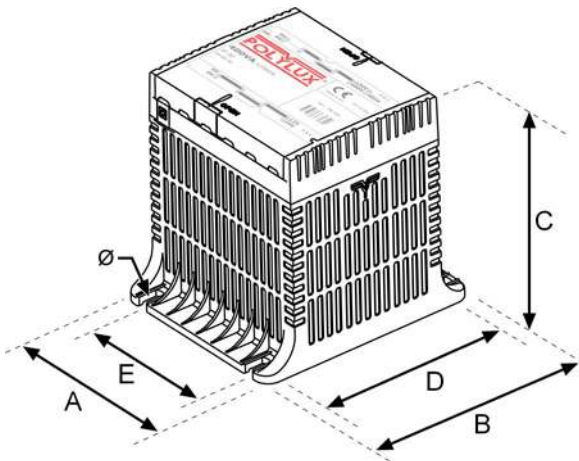

Reference	Dimensions (mm)						Weight (Kg)
	A	B	C	D	E	Ø	
P—25	69	92	80	79	45	5	0.64
P—40	69	92	80	79	45	5	0.79
P—63	84	101	98	88	55	5	1.1
P—100	84	101	98	88	55	5	1.6
P—160	106	123	118	110	74	5	2.3
P—200	106	123	118	110	74	5	2.7
P—250	106	123	118	110	74	5	3.3
P—315	118	138	131	121	88	6	4.1
P—400	118	138	131	121	88	6	4.9
P—500	136	162	156	145	104	6	5.8
P—630	136	162	156	145	104	6	6.8
P—800	136	162	156	145	104	6	8.6

Technical characteristics

Reference	Rating	Instantaneous power cos θ = 0,5	No load voltage Vo	No load losses Po	Short circuit losses Pk (*)	Efficiency η (*)	Short circuit voltage (100°C) Uk (*)
	ta = + 25 °C						
	VA						
P—25	25	43	10	3.4	3.9	77.4	15.5
P—40	40	66	10	4.9	5.0	80.2	12.3
P—63	63	117	10	4.5	10.7	80.6	16.8
P—100	100	174	8	6.8	11.0	84.9	11.3
P—160	160	373	6.8	9.5	16.1	86.2	9.6
P—200	200	494	6.4	8.8	19.1	87.8	8.4
P—250	250	607	5.4	11	21.2	88.6	7.7
P—315	315	967	4.8	10.9	22.4	90.4	6.5
P—400	400	1256	4.4	12.9	24.2	91.5	5.9
P—500	500	1613	3.2	13.9	27.3	92.4	5.1
P—630	630	2440	2.8	19.7	25.4	93.3	4.0
P—800	800	3140	2.7	20.7	28.5	94.2	3.5

References of standard transformers

Rating	Primary voltage	Secondary voltage			
		6 / 12 V	12 / 24 V	24 / 48 V	115 / 230 V
VA	V	References			
25	230 / 400	PA 25	PB25	PC25	PD25
40	230 / 400	PA 40	PB40	PC40	PD40
63	230 / 400	PA 63	PB63	PC63	PD63
100	230 / 400	PA100	PB100	PC100	PD100
160	230 / 400 / 460	PA160	PB160	PC160	PD160
200	230 / 400 / 460	PA200	PB200	PC200	PD200
250	230 / 400 / 460	----	PB250	PC250	PD250
315	230 / 400 / 460	----	PB315	PC315	PD315
400	230 / 400 / 460	----	PB400	PC400	PD400
500	230 / 400 / 460	----	PB500	PC500	PD500
630	230 / 400 / 460	----	----	PC630	PD630
800	230 / 400 / 460	----	----	PC800	PD800

Selection of the safety class

The transformer is delivered with default safety class setting: **CLASS I** which is indicated by the earth symbol below the earth terminal. The earth terminal is located at the secondary side, at the left side of the secondary terminals.



To convert the transformer from **CLASS I** to **CLASE II**, please carry out the following steps:

1. Take out the screw and washer of the earth terminal.
2. Enter the plastic cover (D) in the hole of the earth terminal, press firm until it is well fixed into the terminal.

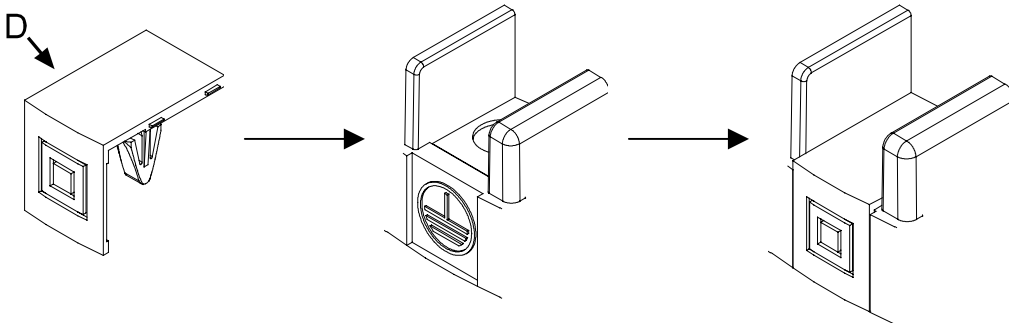

ATTENTION: This cover can not be taken out once it is fixed.

Voltage selection system

Before connecting the transformer, make sure that correct conductor sizes are used. In case the cables have diameter 3mm or less, it is not necessary to break the cable pass zone marked on the transparent cover. For cables with larger diameter, break the cable pass zone.

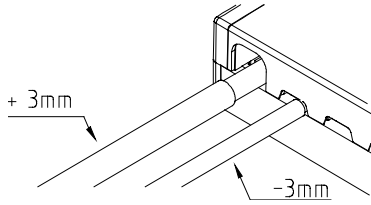

Reference	V21	V22
PA	6 V	12 V
PB	12 V	24 V
PC	24 V	48 V
PD	115 V	230 V

Voltage selection according to transformer rating:

25 and 40 VA

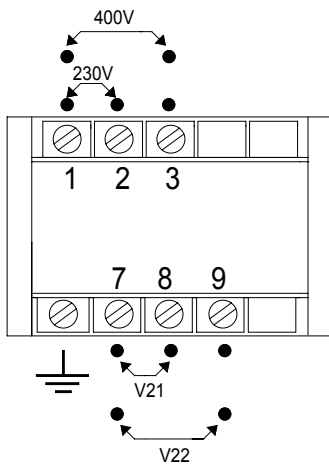

63 and 100 VA

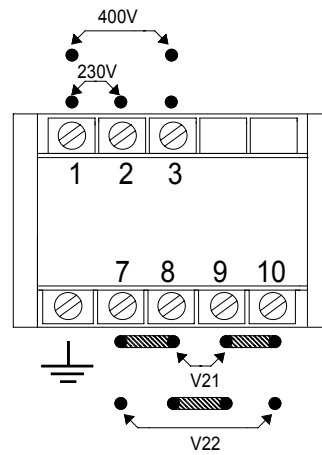

160, 200, 250, 315, 400, 500, 630 and 800 VA

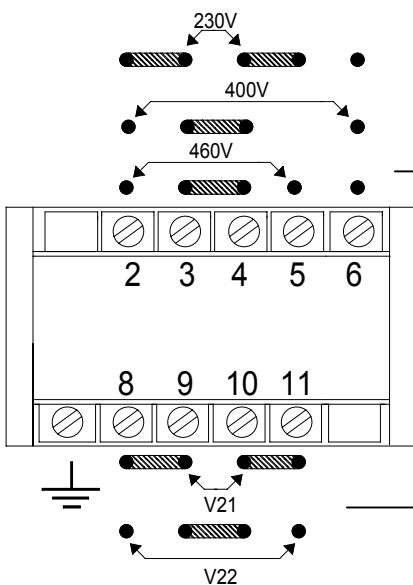

EXAMPLE

To select a supply voltage 400 V place the metal bridge between terminals 3 – 4 and connect the supply cables to terminals 2 – 6.

Placing the bridges between terminals 8 – 9 and 10 – 11, the lowest secondary voltage (V21) is obtained between terminals 9 – 10.

The metals bridges for voltage selection are included in the transformer box.

Protection type and rating

A) Protection at the primary side of the transformer:

The supply circuit of the transformer should only be protected against short circuits, by means by a protection with rating of at least 2 times the nominal current of the transformer due to the inrush current of the transformer (about 20 times I nominal during 10 ms).

PRIMARY						
RATING (VA)	230 V		400 V		460 V	
	Rating (A)	Type	Rating (A)	Type	Rating (A)	Type
25	0.25	T	0.125	T	----	----
40	0.40	T	0.20	T	----	----
63	0.63	T	0.315	T	----	----
100	1.00	T	0.50	T	----	----
160	1.60	D, aM	1.00	D, aM	0.63	T
200	2.00	D, aM	1.00	D, aM	1.00	D, aM
250	2.50	D, aM	1.25	D, aM	1.25	D, aM
315	3.15	D, aM	1.60	D, aM	1.60	D, aM
400	4.00	D, aM	2.00	D, aM	2.00	D, aM
500	5.00	D, aM	2.50	D, aM	2.50	D, aM
630	6.00	D, aM	3.15	D, aM	3.15	D, aM
800	6.30	D, aM	5.00	D, aM	4.00	D, aM

T : T type, temporised fuse / aM : aM type fuse / D : magnetic circuit breaker, curve D

B) Protection at the secondary side of the transformer:

The secondary side of the transformer should be protected against overloads, by means of a protection rated equal or inferior to the secondary current of the transformer.

SECONDARY												
RATING (VA)	6V		12V		24V		48V		115V		230V	
	Rating (A)	Type	Rating (A)	Type	Rating (A)	Type	Rating (A)	Type	Rating (A)	Type	Rating (A)	Type
25	4.00	gG, C	2.00	gG, C	1.00	gG, C	0.50	T	0.20	T	0.10	T
40	6.00	gG, C	3.15	gG, C	1.60	gG, C	0.80	T	0.315	T	0.16	T
63	10.00	gG, C	5.00	gG, C	2.50	gG, C	1.25	gG, C	0.50	T	0.25	T
100	16.00	gG, C	8.00	gG, C	4.00	gG, C	2.00	gG, C	0.80	T	0.40	T
160	25.00	gG, C	12.50	gG, C	6.00	gG, C	3.15	gG, C	1.25	gG, C	0.63	T
200	32.00	gG, C	16.00	gG, C	8.00	gG, C	4.00	gG, C	1.60	gG, C	0.80	T
250	----	----	20.00	gG, C	10.00	gG, C	5.00	gG, C	2.00	gG, C	1.00	gG, C
315	----	----	25.00	gG, C	12.50	gG, C	6.00	gG, C	2.50	gG, C	1.25	gG, C
400	----	----	32.00	gG, C	16.00	gG, C	8.00	gG, C	3.15	gG, C	1.60	gG, C
500	----	----	40.00	gG, C	20.00	gG, C	10.00	gG, C	4.00	gG, C	2.00	gG, C
630	----	----	----	----	25.00	gG, C	12.50	gG, C	5.00	gG, C	2.50	gG, C
800	----	----	----	----	32.00	gG, C	16.00	gG, C	6.00	gG, C	4.00	gG, C

T : T type, temporised fuse / gG : gI – gG type fuse / C : magnetic circuit breaker curve C