

MS3 1.5 ÷ 22kW / 400VAC

Electronic softstarter for squirrel cage motors

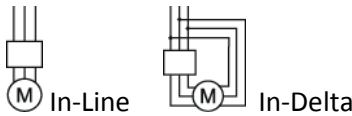
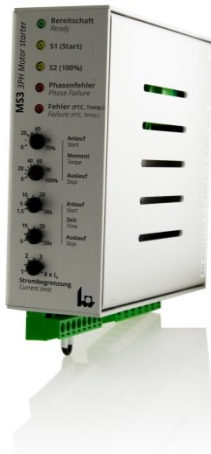

- Full 3PH power control
- Integrated by-pass for high efficiency
- Heavy duty start
- Current limit as standard
- Slim book size build, 42/51mm width
- Integrated Alarms
 - Phase reversal detection /failure
 - Instrument over temperature
 - Motor over temperature (PTC)
- Plugin load terminals from 1.5 ÷ 15kW
- DIN-Rail mounting
- Robust aluminum housing
- Output relays 1 (1.5-15kW) and 3 (18.5-22kW)

Features:

The MS3 is a modern versatile softstarter in a robust built housing, easy mounting and with - only a few steps - easy setup procedure. Integrated by pass and current measurement save wiring and external components. Five front potentiometers allow setting up the Start/Stop time and voltage as well as the maximum current. Five LEDs and 1÷3 relays show immediate the status of the softstarter. The auxiliary supply generated internally from the mains terminals, saves wiring and labor costs. To protect men and machine we have integrated a phase reversal protection. Well dimensioned power devices and real 3PH control makes the MS3 a versatile tool for regular and heavy-duty starting processes. Our up to date control electronics keeps the power losses low for high efficient operations during the next years. The MS3 is usable for "In-Line" and "In-Delta" motor wiring.

Versatile usability:

- Machinery and apparatus
- Cooling and ventilation
- Conveyor / Elevator
- Pump (centrifugal/piston style)
- Packaging machines
- Test rigs
- Circular saw/milling machines
- Compressor
- Power Press

Quick selection guide	
Regular start, class 10	Heavy duty start, class 30
<ul style="list-style-type: none"> • Fan • Centrifugal pump • Compressor • Conveyor belt • Elevator • Escalator 	<ul style="list-style-type: none"> • Centrifugal fan • Crusher • Conveyor belt (long) • Mill • Mixer • Stirrer
Select size according to nominal motor power	Select size one step lager then Nominal motor power

Type	Order code	P _{Motor} [kW]	I _{start} nom. [A]	I _{start} max. [A]	Weight [kg]	Build size	Dim. WxHxD [mm]
MS3 1.5	490459	1,5	3,5	12	0,50	A	42x128x130
MS3 2.2	490460	2,2	4,5	15	0,50	A	42x128x130
MS3 3.0	490461	3,0	6,6	20	0,50	A	42x128x130
MS3 4.0	490462	4,0	8,5	25	0,50	A	42x128x130
MS3 5.5	490463	5,5	12	40	0,50	A	42x128x130
MS3 7.5	490464	7,5	18	50	0,95	B	51x141x181
MS3 11	490465	11	25	70	0,95	B	51x141x181
MS3 15	490466	15	30	90	0,95	B	51x141x181
MS3 18.5	490467	18,5	37	110	1,65	C	51x224x179
MS3 22	490468	22	45	140	1,65	C	51x224x179

Technical data

Operating voltage	3x400V AC ±15%
Auxiliary supply	standard: internal generated, (optional: 24V DC external)
Frequency	50/60Hz self-synchronizing
Phase rotation	clockwise
Controlled phase	3- L1, L2, L3
Starts per hour	30 / restart every 2 min
Operating temperature	-20° C ÷ +50° C
Storage temperature	-25° C ÷ +75° C
Humidity	95% rF (not condensing)
Altitudes	Up to 1000m above sea, (above derating 2,2% / 100m)
Mechanical protection	IP40
Terminals	plugin (control & power), > 15kW plugin (control) and fixed (power)
LED-Indication	ready, S1 (start/run), S2 (top of ramp), phase detection error, Alarm (PTC, over temperature)
Adjustable parameter	Start/Stop time, Start/Stop voltage, current limit
Power sizes	1,5kW ÷ 22kW (related to motor power)
Internal protection (Alarm)	- Instrument temperature - PTC-input for motor - Phase reversal and phase fail
Operating category	AC-53a according IEC
Position	vertical
Control inputs	Fully isolated (start, PTC-motor)
Output 1 or 3	- Common Alarm (normally closed) - S1 (Run) (only MS3 18,5 and 22) - S2 (top of ramp) (only MS3 18,5 and 22)
CE-Standard	DIN EN 60947-4-2, 2006/95/EG

Instrument Front

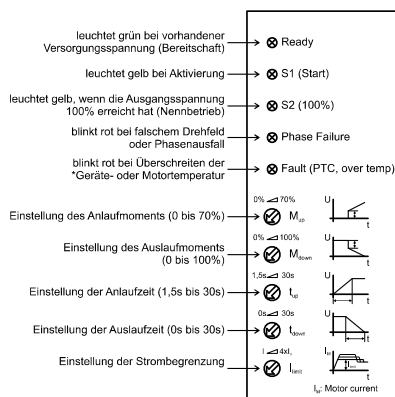

Wiring diagram (<18.5kW)

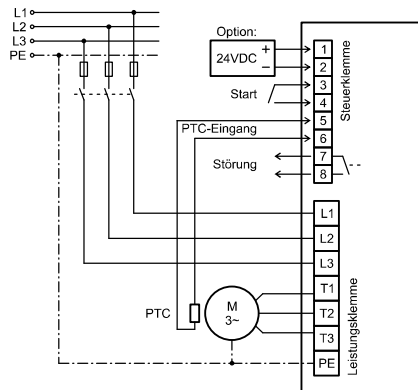

additional outputs 18.5 - 22kW

