

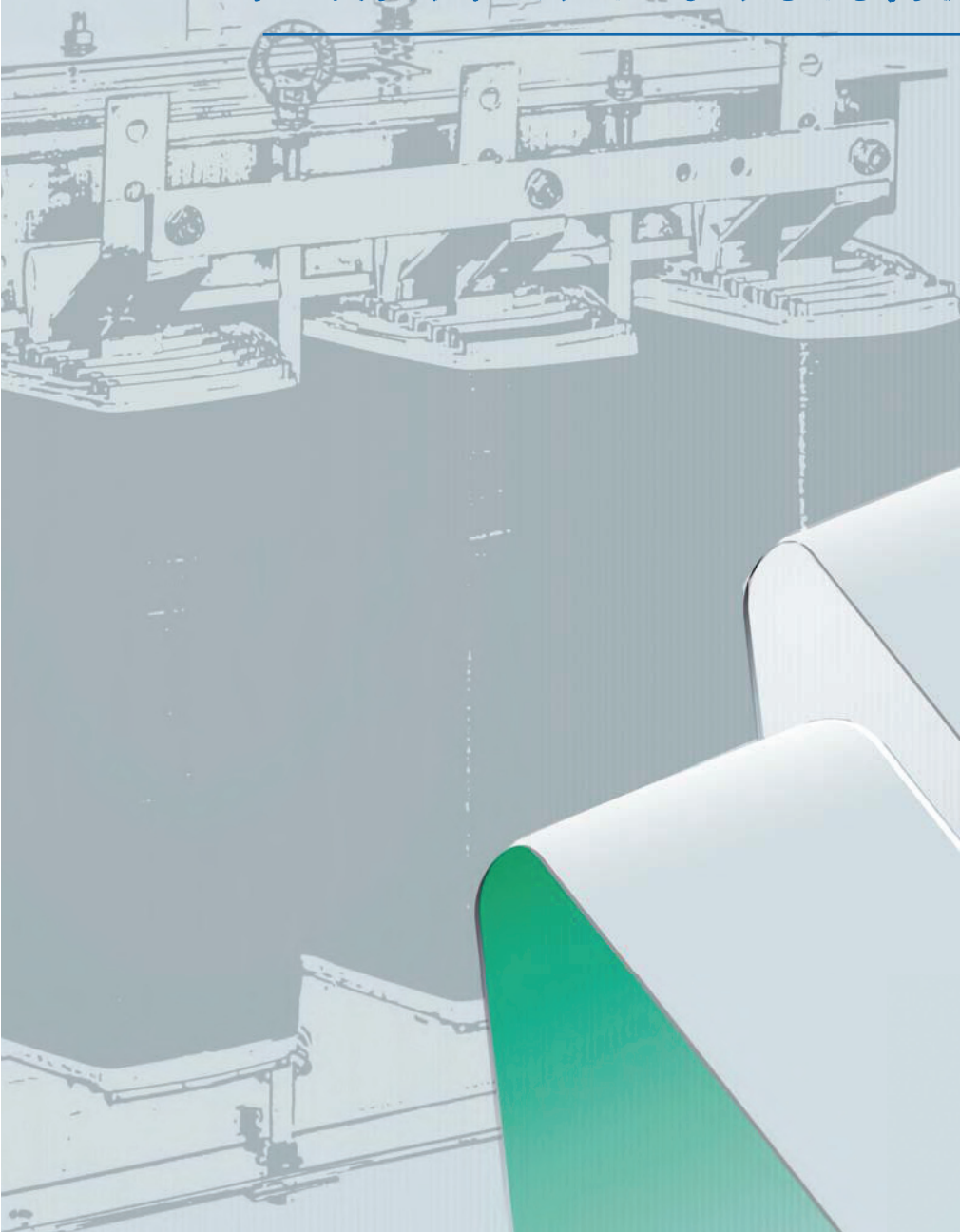

ELECTRIC TRANSFORMERS SINCE 1980

# ELECTRIC TRANSFORMERS POWER FOR YOUR SYSTEM



METH srl designs and manufactures electric transformers since 1980 focusing on the quality of its product performance, thanks to 30 years of experience in this business. Since 1998 multiple national and international certifications are the result of a continuous effort in updating our products to meet worldwide standards and requirements.

Meth is specialized in manufacturing **single-phase electric transformers from 3,2VA to 80kVA**, **three-phase transformers from 100VA to 1000kVA**, for applications in different fields from industrial to automation to photovoltaic to marine, **three-phase auto-transformers and three-phase reactors**.

Depending on the configuration, METH transformers bear the European or North American Approvals such as UL, KEMA and ENEC and Middle East Approvals (CoC - ex SASO). Meth experience and technology allow to develop and manufacture in a short time new products to meet any customers' requests and to improve new products programs.

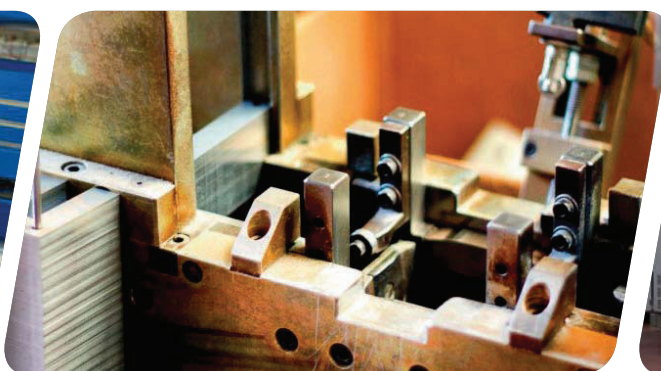

**QUALITY** Meth Quality System, certified since 1998, rules all the processes: customers and suppliers orders management, preliminary controls, manufacturing cycles, final tests, handling of non conformity. As further confirmation of the constant quality-research over the years, Meth has obtained the following certifications:

- UL-CSA for single phase transformers up to 10KVA and for three-phase transformers up to 80KVA. Meth is one of the few manufactures in Europe with UL-CSA LISTED certification.
- UL-CSA Insulation System class B-F-H.
- UL-CSA Insolution System for Three-Phase auto-transformers up to 250 KVA.
- ENEC-KEMA for single phase transformers up to 2KVA.
- GL for some single-phase transformers for marine use up to 1kVA.

Certification companies inspections are regularly scheduled, ensuring a constant quality level of the products.

**PLANNING** Meth obtains the transformers parameters that will be tested at the end of production, such as over-temperature, losses, performance, rigidity, insulation, induced voltage, ecc., using “RALE” calculation programs. During the calculation spacers and cooling channels are properly sized to assure a long and reliable service life.

**PRODUCTION** The entire manufacturing process is carried out internally: preliminary controls, automatic winding for small transformers and winding on machine for flat cable, copper or aluminium strip for bigger transformers, core-assembly and soaking or resin. At the end of production all transformers are tested internally with instruments according to ISO specifications and regularly calibrated in SIT centres.

**TEST** Meth transformers are 100% tested and test results are stored in Meth database and available on customers request. Meth test equipment allows to carry out all tests required by the standards. At the moment the equipment is available for the following tests: no-load losses, load losses, harmonic analysis, resistance, rigidity and insulation measurement, induced voltage, inrush current.



[www.meth.it](http://www.meth.it)

Meth Kft is specialized in manufacturing **single-phase electric transformers from 30VA to 5000VA** for industrial and automation applications and **three-phase filter reactors**. The Company is focused on the quality of product performance and deliveries in short time, empowered by the 30-year-experience gained in this business by Meth srl Italy.

Meth Kft performance is based on three statements which represent its core value: Technology and Customization, Dynamic Know-how and Cost Effectiveness. The production cycle refers to Meth srl Italy method and is based on three steps: planning, production, test.



#### **DYNAMIC KNOW-HOW AND COST EFFECTIVENESS**

Meth Kft is a dynamic and proactive company, focused on the quality of product performance and the optimization of delivery time. Thanks to technology efficiency and reduced cost line production Meth kft offers to own customers good products and competitive prices.

**PLANNING** All Meth Kft products are designed by technical dpt. using high-technology calculations programs like RALE for a proper evaluation of transformers electrical and technical features such as over-temperature, losses, performance, rigidity, insulation, induced voltage, dimensions and weight.

**PRODUCTION** The entire manufacturing process is carried out internally through a computerized production cycle. All the transformers are completely impregnated with resin. Preliminary check of raw materials and regular inspection of every single step during the production process are carried out to assure the best quality performance of the products.

**TEST** All Meth Kft transformers are tested internally at the end of the production process with routine tests. Test equipment allows to implement type tests required by the standards such as no-load losses, load losses, resistance, rigidity and insulation measurement, inrush current. Test results are stored in the Company database and available upon customer request.

## FOCUS ON METH CERTIFICATIONS



CE marking is the manufacturer's declaration that the product meets the requirements of the applicable EC directives. The CE marking is a symbol of free marketability in the European Economic Area (Internal Market)



UL is one of several companies approved to perform safety testing by the US federal agency Occupational Safety and Health Administration (OSHA)



GL is the abbreviation for "German Llyod", which certifies the products compliance with marine standards



ENEC-KEMA is an abbreviation for "European Norms Electrical Certification". It gives customers the assurance that a product has been certified by one of the national certification institutes in Europe and it complies with the relevant European safety standards



Coc Certification (ex SASO) allows the company to export in Saudi Arabia market, as the products passed strict technical test in a certified laboratory



## 36.01 /// SINGLE-PHASE TRANSFORMERS

<b>T1-T1Q- T1ULF-T1UL</b>		Low-voltage single-phase isolating and safety transformers ENEC and UL-CSA marked	pag. 8
<b>T1B</b>		Low-voltage single-phase isolating and safety transformers input/output in 2 sides – class F	pag. 11
<b>T1C</b>		Low-voltage single-phase isolating and safety transformers input/output in 1 side – class F	pag. 12
<b>T1-IT</b>		Low-voltage single-phase isolating and safety transformers – class B	pag. 13
<b>T1P</b>		Low-voltage single-phase isolating and safety transformers with resettable switch	pag. 14
<b>T1U</b>		Low-voltage single-phase univesal input low-voltage isolating and safety transformers	pag. 15
<b>T1L</b>		Low-voltage single-phase isolating and safety transformers for screw or DIN bar installation IP20	pag. 16
<b>T2</b>		Low-voltage single-phase dry-type transformers from 5 to 80 kVA	pag. 17
<b>T2H</b>		Low-voltage single-phase transformers for medical locations	pag. 18
<b>T1Q-GL</b>		Low-voltage single-phase transformers for marine applications	pag. 19
<b>T5-T6-T7</b>		PCB transformers	pag. 20
		Other transformers	pag. 22

## 36.02 /// THREE-PHASE TRANSFORMERS & AUTO-TRANSFORMERS

<b>T3TULF-T3TUL</b>		Low-voltage three-phase general purpose transformers UL-CSA marked up to 25 kVA	pag. 24
<b>T3T</b>		Low-voltage three-phase isolating and safety transformers up to 40kVA	pag. 26
<b>T3T</b>		Low-voltage three-phase dry-type power transformers up to 1000kVA	pag. 28
<b>T3TAH-UL</b>	<b>NEW</b>	Low-voltage three-phase industrial control transformers UL-CSA up to 80kVA	pag. 30
<b>AT3TH-UL</b>	<b>NEW</b>	Low-voltage three-phase industrial control auto-transformers UL-CSA up to 250kVA	pag. 31
<b>T3X</b>		Low-voltage three-phase dry-type power transformers with protection degree IP55	pag. 32
<b>T3SL</b>		LOW-LOSSES three-phase SLIM-LINE transformers ECO DESIGN	pag. 33
<b>T3T-FTV</b>		Low-voltage three-phase isolating transformers for “Renewable Energies” class B	pag. 34
		Three-phase auto-transformers and reactors motors starting	pag. 36

## 36.03 /// REACTORS

<b>R3F</b>	<b>NEW</b>	Three-phase filter reactors	pag. 38
<b>R3L</b>		Three-phase smoothing reactors	pag. 39

## 36.04 /// STEEL ENCLOSURE

<b>IP21-IP23-IP55</b>		Steel enclosure for three-phase transformers	pag. 40
-----------------------	--	--	---------

## 36.05 /// TECHNICAL NOTES

		Technical Notes	pag. 41
--	--	-----------------	---------

**36.01 ///**  
**SINGLE-PHASE**  
**TRANSFORMERS**

[www.meth.it](http://www.meth.it)



CoC certified products: T1ULF and T1  
For technical and electrical data see page 10 (T1ULF) and 11 (T1)

### General data

Input voltage	T1Q : 200-440 V
	T1ULF-T1UL : 100-600 V
Output voltage	T1Q : 12-440 V
	T1ULF-T1UL : 12-600 V
Rated power	T1Q : 30-2000 VA
	T1ULF : 30-5000 VA
	T1UL : >5 KVA - 10 KVA

Insulation class	class F
Temperature class	T1Q : class B
	T1ULF-T1UL : class F
Ambient temperature	Ta=40°C
Protection degree	IP 00 - class I
Test voltage	4,2 KV/1'
Terminals	terminal blocks

### Application:

Isolating transformer with secondary voltage > 50 V  
Safety transformer with secondary voltage ≤ 50 V safety transformer  
They are suitable for any industrial/civil use for the electrical isolation of the input and output sides. Construction in accordance with the following standards:

### Standard

CEI-EN 61558,2-4 – isolating transformers
IEC 61558,2-4 – isolating transformers
UL 5085 1-2 – low-voltage transformers
CEI-EN 61558,2-6 – safety transformers
IEC 61558,2-6 – safety transformers
CSA 22.2, No66

### T1Q: ENEC marked

### T1ULF-T1UL: UL-CSA marked

### Certifications

	KEMA FILE 3502609.01-02-03-04-05
	FILE E169331-vol. 2-sec. 1-2
	FILE E169331-vol. 1-sec. 1-2
	FILE E215141-vol. 1-sec. 1





## Technical data T1 CUSTOMIZED PRODUCT

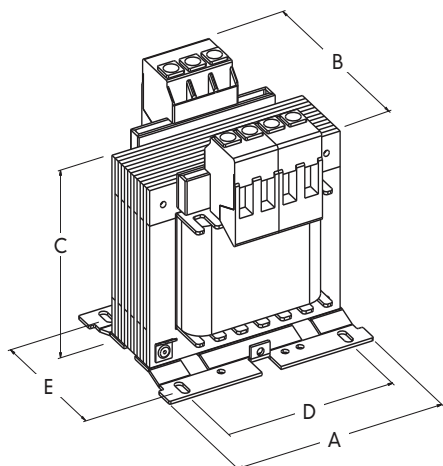

CODE	RATED POWER VA	APPROVALS	DIMENSIONS (mm)					WEIGHT Kg
			A	B	C	D	E	
T1-30...	30	CE	77	81	77	60	43	1,1
T1-50...	50	CE	77	85	77	60	48	1,2
T1-75...	75	CE	86	85	82	70	55	1,45
T1-100...	100	CE	86	95	82	70	65	2
T1-150...	150	CE	98	98	95	80	69	2,6
T1-200...	200	CE	98	113	95	80	84	3,1
T1-250...	250	CE	122	103	110	100	75	3,6
T1-300...	300	CE	122	108	110	100	80	4,4
T1-400...	400	CE	122	118	110	100	90	5,7
T1-500...	500	CE	122	138	110	100	110	7
T1-600...	600	CE	153	116	136	125	93	7,4
T1-800...	800	CE	153	136	136	125	113	9,8
T1-1000...	1000	CE	153	156	136	125	133	12,1
T1-1250...	1250	CE	193	125	176	160	96	14
T1-1500...	1500	CE	193	131	176	160	102	16
T1-2000...	2000	CE	193	151	176	160	122	20
T1-3000...	3000	CE	193	192	176	160	162	22
T1-4000...	4000	CE	240	230	230	180	165	45
T1-5000...	5000	CE	240	240	230	180	180	50
T1-6000...	6000	CE	240	260	240	180	200	60



## Technical data T1Q

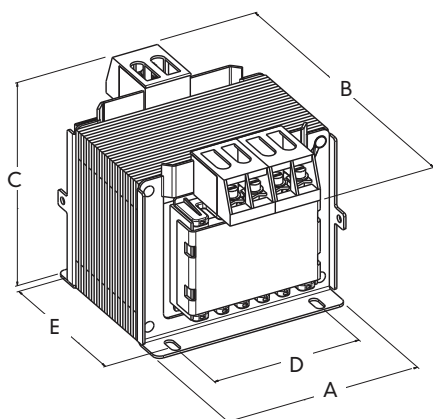

CODE	RATED POWER VA	APPROVALS	DIMENSIONS (mm)					DIMENSIONS ACCORDING TO DIN STANDARD (mm)					WEIGHT Kg
			A	B	C	D	E	A	B	C	D	E	
T1Q-30...	30	E5	77	81	77	60	43	76	72	89	56	45	1,1
T1Q-50...	50	E5	77	85	77	60	48	76	78	89	56	50	1,2
T1Q-75...	75	E5	86	85	82	70	55	85	85	98	64	54	1,45
T1Q-100...	100	E5	86	95	82	70	65	85	94	98	64	64	2
T1Q-150...	150	E5	98	98	95	80	69	96	92	109	84	70	2,6
T1Q-200...	200	E5	98	113	95	80	84	96	107	109	84	85	3,1
T1Q-250...	250	E5	122	103	110	100	75	121	95	123	90	70	3,6
T1Q-300...	300	E5	122	108	110	100	80	121	105	123	90	80	4,4
T1Q-400...	400	E5	122	118	110	100	90	121	115	123	90	90	5,7
T1Q-500...	500	E5	122	138	110	100	110	121	135	123	90	110	7
T1Q-600...	600	E5	153	116	136	125	93	151	117	140	122	90	7,4
T1Q-800...	800	E5	153	136	136	125	113	151	137	140	122	110	9,8
T1Q-1000...	1000	E5	153	156	136	125	133	151	157	140	122	130	12,1
T1Q-1250...	1250	E5	193	125	176	160	96	193	125	176	160	96	14
T1Q-1500...	1500	E5	193	131	176	160	102	193	131	176	160	102	16
T1Q-2000...	2000	E5	193	151	176	160	122	193	151	176	160	122	20

## Technical data T1ULF (industrial control transformers) T1UL (general purpose transformers)

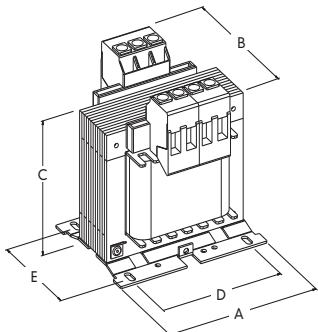

Fig. 1

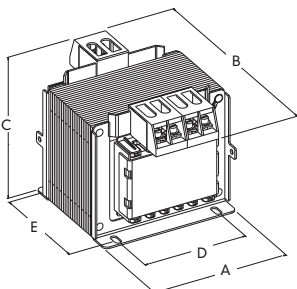

Fig. 2

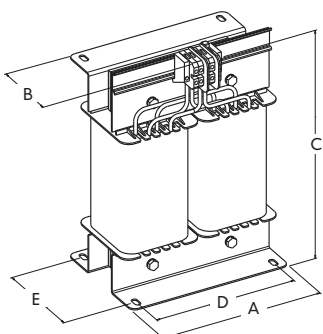

Fig. 3

CODE	RATED POWER	APPROVALS	DIMENSIONS (mm)					DIMENSIONS ACCORDING TO DIN STANDARD (mm)					WEIGHT	FIG.
			A	B	C	D	E	A	B	C	D	E		
T1ULF-30...	30		77	81	77	60	43	76	72	89	56	45	1,1	1-2
T1ULF-50...	50		77	85	77	60	48	76	78	89	56	50	1,2	1-2
T1ULF-75...	75		86	85	82	70	55	85	85	98	64	54	1,45	1-2
T1ULF-100...	100		86	95	82	70	65	85	94	98	64	64	2	1-2
T1ULF-150...	150		98	98	95	80	69	96	92	109	84	70	2,6	1-2
T1ULF-200...	200		98	113	95	80	84	96	107	109	84	85	3,1	1-2
T1ULF-250...	250		122	103	110	100	75	121	95	123	90	70	3,6	1-2
T1ULF-300...	300		122	108	110	100	80	121	105	123	90	80	4,4	1-2
T1ULF-400...	400		122	118	110	100	90	121	115	123	90	90	5,7	1-2
T1ULF-500...	500		122	138	110	100	110	121	135	123	90	110	7	1-2
T1ULF-600...	600		153	116	136	125	93	151	117	140	122	90	7,4	1-2
T1ULF-800...	800		153	136	136	125	113	151	137	140	122	110	9,8	1-2
T1ULF-1000...	1000		153	156	136	125	133	151	157	140	122	130	12,1	1-2
T1ULF-1250...	1250		193	125	182	122	96	-	-	-	-	-	14	1-2
T1ULF-1500...	1500		193	131	182	160	102	-	-	-	-	-	16	1-2
T1ULF-2000...	2000		193	151	182	160	122	-	-	-	-	-	20	1-2
T1ULF-2500...	2500		193	171	182	160	142	-	-	-	-	-	22	2-3
T1ULF-3000...	3000		200	155	300	150	126	-	-	-	-	-	31	3
T1ULF-4000...	4000		240	175	357	205	104	-	-	-	-	-	37	3
T1ULF-5000...	5000		240	185	357	205	114	-	-	-	-	-	40	3
T1UL-6000...	6000		240	205	357	205	134	-	-	-	-	-	47	3
T1UL-7500...	7500		280	228	410	233	152	-	-	-	-	-	57	3
T1UL-10000...	10000		280	252	410	233	175	-	-	-	-	-	75	3



All the above items are also available with transparent varnish

### Electrical data Suitable for T1Q - T1ULF - T1UL

RATED POWER	LOSSES (W)		EFFICIENCY	U <sub>cc</sub>	ΔV	INRUSH CURRENT
	no-load	load				
VA						
30	3	3,2	82,8	9,5	9,6	20
50	3,5	6,7	83,1	11,8	11,8	18
75	4	8	86,2	10,6	10	17
100	5,2	6,8	86,9	8,4	8,2	24
150	6,5	12,5	88,9	9,4	8,1	20
200	8,2	16	89,5	9	7,7	19
250	9,1	17,5	90,5	10,2	7,2	19
300	10,5	18,7	91,2	9,2	6,4	19
400	12,5	28,5	91	10	7,1	18
500	15,6	29	91,9	8,6	5,9	20
600	17	36	92,3	5,6	5,6	23
800	20	46	92,4	5	5,4	22
1000	25	47	93,4	4,5	4,5	23
1250	32	48	93,9	3,9	3,8	22
1500	34	63	93,9	4,3	4,1	22
2000	41	79	94,3	4	3,8	21
2500	50	80	95	3,5	3,2	21
3000	60	97	95	3,4	3,2	20
4000	60	150	95,2	4,1	3,8	20
5000	65	170	95,6	3,7	3,4	18
6000	65	185	96	3,4	3,1	18
7500	75	220	96,2	3,2	2,4	17
10000	100	250	96,7	2,9	2,4	17

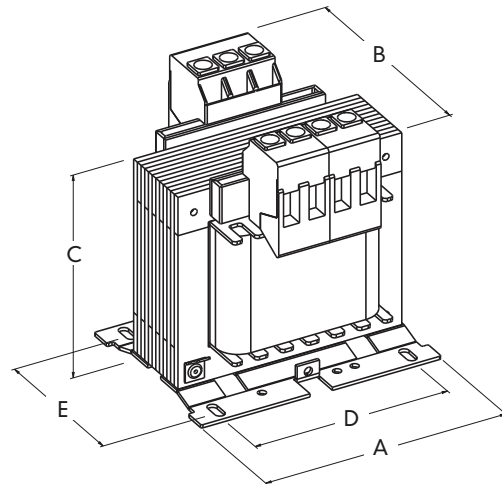

**General data**

**2 input voltage/1 output voltage  
output in two sides**

Input voltage	230-400 V or others upon request
Output voltage	24 V/115 V or others upon request
Rated power	30-5000 VA
Insulation class	class F

Temperature class	class B
Ambient temperature	Ta=40°C
Protection degree	IP 00 - class I
Test voltage	4,2 KV/1'
Terminals	terminal blocks

**Application:**

Single-phase control, isolating and safety transformers designed combining reliable performance and cost-effectiveness. They are completely impregnated with resin and have faston or screw earth connection, 4 sqmm terminal blocks, input and output in two sides. Construction in accordance with the following standards:

**Standard**

CEI-EN 61558,2-4 – isolating transformers
CEI-EN 61558,2-6 – safety transformers
IEC 61558,2-4 and 2-6

**Technical data T1B**

**Electrical data**

CODE	RATED POWER		DIMENSIONS (mm)					WEIGHT Kg	LOSSES (W)		EFFICIENCY %	Ucc %	ΔV %
	VA		A	B	C	D	E		no-load	load			
T1B-30...	30		76	68	89	55	40	1	2,1	5,8	76,5	13,2	13
T1B-50...	50		76	73	89	55	45	1,1	2,7	9,5	81	12,5	12,4
T1B-75...	75		76	87	89	55	59	1,3	3,9	11	83,8	12,4	12,7
T1B-100...	100		85	87	95	64	59	1,8	4,7	13,7	84,6	11,8	12,1
T1B-160...	160		98	87	106	84	66	2,2	5,8	17,9	86,5	10,5	10,7
T1B-200...	200		98	97	106	84	76	3	7	22,8	87,1	10,2	10,3
T1B-250...	250		98	107	106	84	86	3,5	8,4	28,3	87,3	10	10,2
T1B-300...	300		108	107	115	90	86	4,1	9,8	31	88,4	9,2	9,3
T1B-400...	400		122	102	121	90	84	4,9	9,4	34	90,3	7,9	7,9
T1B-500...	500		122	117	121	90	99	6	11	34,1	92	6,4	6,5
T1B-600...	600		151	94	142	123	79	7,8	12,3	39	92,2	6,4	6,2
T1B-800...	800		151	114	142	123	99	10,4	17,2	40,4	93,4	4,9	4,8
T1B-1000...	1000		151	124	142	123	109	11,4	19	47,3	93,5	4,6	4,5
T1B-1500...	1500		192	125	176	160	96	14	30	76	93,5	4,9	4,8
T1B-2000...	2000		192	151	176	160	122	20,1	40	88	94	4,4	4,3
T1B-2500...	2500		192	171	176	160	142	23	52	96	94,5	3,8	3,7
T1B-3000...	3000		192	191	176	160	162	26	61	103	94,9	3,5	3,4
T1B-4000...	4000		240	230	230	180	165	45	85	100	95,6	3	3,5
T1B-5000...	5000		240	240	230	180	180	50	90	105	96	3	3,6

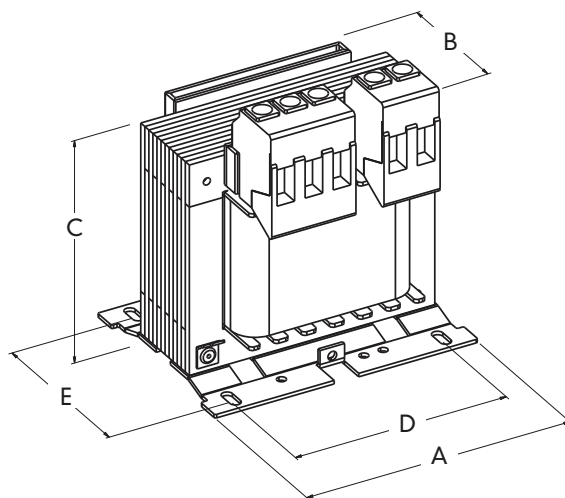
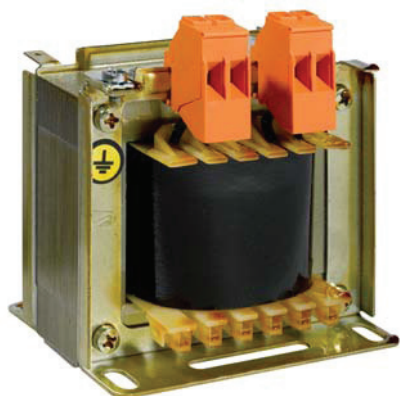

### General data

#### 1 input voltage/1 output voltage output in one side

Rated input voltage	230 V or others upon request
Rated output voltage	24 V/115 V or others upon request
Rated power	30-5000 VA
Insulation class	class F
Temperature class	class B

Ambient temperature	Ta=40°C
Protection degree	IP 00 - class I
Test voltage	4,2 KV/1'
Terminals	terminal blocks

### Application:

Single-phase control, isolating and safety transformers designed combining reliable performance and cost-effectiveness.

They are completely impregnated with resin and have faston or screw earth connection, 4 sqmm terminal blocks, input and output in the same side.

Construction in accordance with the following standards:

### Standard

CEI-EN 61558,2-4 – isolating transformers

CEI-EN 61558,2-6 – safety transformers

IEC 61558,2-4 and 2-6

### Technical data T1C

### Electrical data

CODE	RATED POWER VA	DIMENSIONS (mm)					WEIGHT Kg	LOSSES (W)		EFFICIENCY %	U <sub>cc</sub> %	ΔV %
		A	B	C	D	E		no-load	load			
T1C-30...	30	76	68	89	55	40	1	2,1	5,8	76,5	13,2	13
T1C-50...	50	76	73	89	55	45	1,1	2,7	9,5	81	12,5	12,4
T1C-75...	75	76	87	89	55	59	1,3	3,9	11	83,8	12,4	12,7
T1C-100...	100	85	87	95	64	59	1,8	4,7	13,7	84,6	11,8	12,1
T1C-160...	160	98	87	106	84	66	2,2	5,8	17,9	86,5	10,5	10,7
T1C-200...	200	98	97	106	84	76	3	7	22,8	87,1	10,2	10,3
T1C-250...	250	98	107	106	84	86	3,5	8,4	28,3	87,3	10	10,2
T1C-300...	300	108	107	115	90	86	4,1	9,8	31	88,4	9,2	9,3
T1C-400...	400	122	102	121	90	84	4,9	9,4	34	90,3	7,9	7,9
T1C-500...	500	122	117	121	90	99	6	11	34,1	92	6,4	6,5
T1C-600...	600	151	94	142	123	79	7,8	12,3	39	92,2	6,4	6,2
T1C-800...	800	151	114	142	123	99	10,4	17,2	40,4	93,4	4,9	4,8
T1C-1000...	1000	151	124	142	123	109	11,4	19	47,3	93,5	4,6	4,5
T1C-1500...	1500	192	125	176	160	96	14	30	76	93,5	4,9	4,8
T1C-2000...	2000	192	151	176	160	122	20,1	40	88	94	4,4	4,3
T1C-2500...	2500	192	171	176	160	142	23	52	96	94,5	3,8	3,7
T1C-3000...	3000	192	191	176	160	162	26	61	103	94,9	3,5	3,4
T1C-4000...	4000	240	230	230	180	165	45	85	100	95,6	3	3,5
T1C-5000...	5000	240	240	230	180	180	50	90	105	96	3	3,6

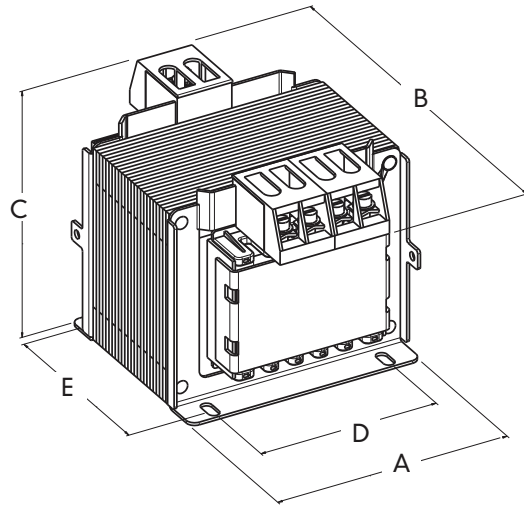

### General data

#### input-output in two sides

Rated input voltage	230-400 V (others upon request)
Rated output voltage	24V or 115V (others upon request)
Frequency	50/60 Hz
Rated power	30-5000 VA
Insulation class	class F
Temperature class	class B

Ambient temperature	Ta=40°C
Operating time	continuous
Protection degree	IP 00 - class I
Terminal protection degree	IP 20
Test voltage	4,2 KV/1'
Terminals	terminal blocks

#### Application:

Single phase control, isolating and safety transformers designed combining reliable performance and cost-effectiveness. They are completely impregnated with resind. Input and output in two sides. Costruction in accordance with the following standards:

#### Standard

CEI - EN 61558,2-4 – isolating transformers

CEI - EN 61558,2-6 – safety transformers

IEC 61558,2-4 and 2-6

### Technical data T1-IT

CODE	RATED POWER VA	DIMENSIONS (mm)					WEIGHT Kg	LOSSES (W)		EFFICIENCY %	U <sub>cc</sub> %	ΔV %
		A	B	C	D	E		no-load	load			
T1-IT-30...	30	76	70	76	55	39	1	2,1	5,8	76,5	13,2	13
T1-IT-50...	50	76	75	76	55	44	1,1	2,7	9,5	81	12,5	12,4
T1-IT-75...	75	76	90	76	55	59	1,3	3,9	11	83,8	12,4	12,7
T1-IT-100...	100	85	88	84	70	61	1,8	4,7	13,7	84,6	11,8	12,1
T1-IT-160...	160	98	94	94	80	64	2,2	5,8	17,9	86,5	10,5	10,7
T1-IT-200...	200	98	104	94	80	74	3	7	22,8	87,1	10,2	10,3
T1-IT-250...	250	98	114	94	80	84	3,5	8,4	28,3	87,3	10	10,2
T1-IT-300...	300	108	112	94	84	83	4,1	9,8	31	88,4	9,2	9,3
T1-IT-400...	400	122	107	110	100	85	4,9	9,4	34	90,3	7,9	7,9
T1-IT-500...	500	122	122	110	100	100	6	11	34,1	92	6,4	6,5
T1-IT-600...	600	151	100	133	125	90	7,8	12,3	39	92,2	6,4	6,2
T1-IT-800...	800	151	120	133	125	110	10,4	17,2	40,4	93,4	4,9	4,8
T1-IT-1000...	1000	151	130	133	125	120	11,4	19	47,3	93,5	4,6	4,5
T1-IT-1500...	1500	192	125	176	160	96	14	30	76	93,5	4,9	4,8
T1-IT-2000...	2000	192	151	176	160	122	20,1	40	88	94	4,4	4,3
T1-IT-2500...	2500	192	171	176	160	142	23	52	96	94,5	3,8	3,7
T1-IT-3000...	3000	192	191	176	160	162	26	61	103	94,9	3,5	3,4

### Electrical data

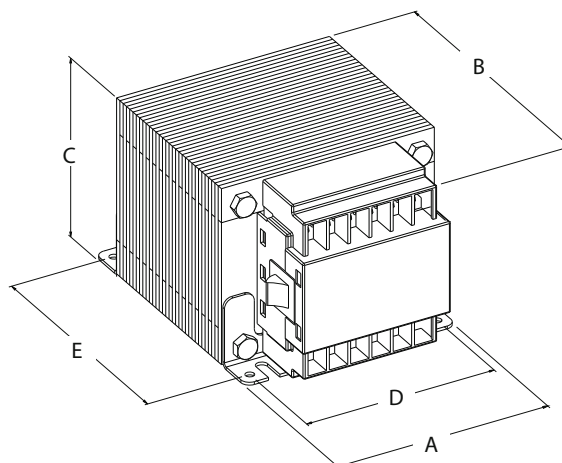

### General data

Rated input voltage	230-400 V
Rated output voltage	12/24/48 V (others upon request)
Rated power	30-125 VA
Insulation class	class F
Temperature class	class B

Ambient temperature	Ta=40°C
Protection degree	IP 00 - class I
Test voltage	4,2 KV/1'
Terminals	Faston 6,3 sqmm

### Application:

Single-phase isolating and safety transformers suitable for any industrial or civil use for the electrical isolation of the input and output sides with resettable switch on the output .  
Construction in accordance with the following standards:

### Standard

CEI-EN 61558,2-4 and 2-6 – isolating and safety transformers  
IEC 61558,2-4 and 2-6

### Technical data T1P

CODE	RATED POWER VA	DIMENSIONS (mm)					WEIGHT Kg	LOSSES (W)		EFFICIENCY %	Ucc %	DV %
		A	B	C	D	E		no-load	load			
T1P-30	30	75	73	63	55	45	1	2,5	3,8	83,2	11,2	10,9
T1P-50	50	75	73	63	55	45	1,1	2,9	7,1	83,4	12,5	12,4
T1P-63	63	75	83	63	55	55	1,3	3,2	8	84,9	12,2	11,8
T1P-75	75	75	88	63	55	60	1,5	3,8	9,7	85,1	12,1	11,7
T1P-100	100	85	95	72	64	61	1,9	4,5	11,8	86,1	11,8	11,3
T1P-125	125	85	105	72	64	71	2,3	5,5	13,4	87	10,9	10,2

### Electrical data

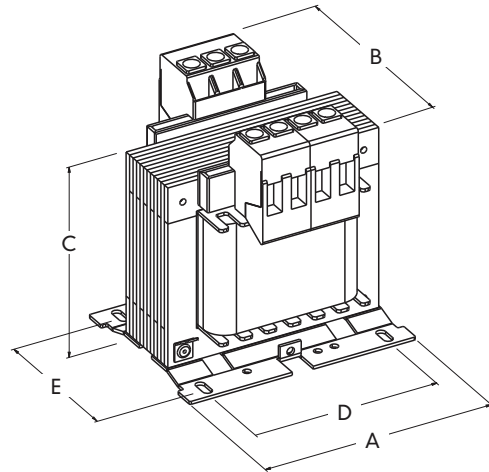

### General data

Rated input voltage (standard)	208-230-380-400-420-440-460-480-500-525-550 V
Rated output voltage	2x115 V or 2x12 V or 2x24 V
Rated power	from 150 to 1000 VA
Insulation class	class F

Temperature class	class F
Ambient temperature	Ta=40°C
Protection degree	IP 00 - class I
Test voltage	4,2 KV/1'
Terminals	terminal blocks

### Application:

Suitable for any industrial application, where different input voltages are required.

Construction in accordance with the following standards:

### Certifications



FILE E169331-vol. 2-sec. 1-2



FILE E215141-vol. 1-sec. 1

### Standard

CEI-EN 61558,2-4 and 2-6 – isolating and safety transformers

IEC 61558,2-4 and 2-6

UL 5085 1 and 2 – low voltage transformers

CSA 22.2 No.66

### Technical data T1U

CODE	RATED POWER VA	DIMENSIONS (mm)					WEIGHT Kg
		A	B	C	D	E	
T1U-150...	150	96	92	105	84	75	2,6
T1U-250...	250	121	95	125	90	70	3,6
T1U-400...	400	121	115	125	90	90	5,7
T1U-500...	500	121	135	125	90	110	7
T1U-630...	630	151	117	140	120	90	7,4
T1U-800...	800	151	137	140	120	110	9,8
T1U-1000...	1000	151	157	140	120	130	12,1

### STANDARD WIRING DIAGRAM

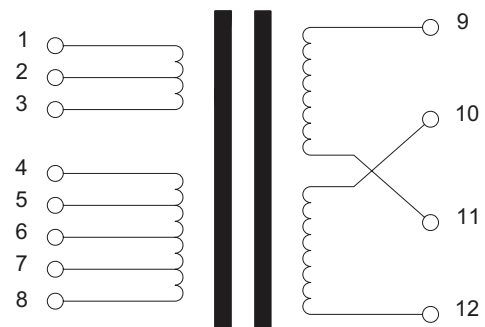

Other configurations available upon request

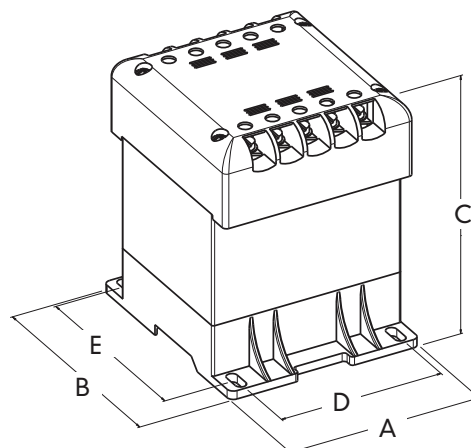

### General data

Rated input voltage	230-400±15 V
Rated output voltage	2X12 V or 2x115 V
Rated power	50-400 VA
Insulation class	class F
Temperature class	class B

Protection class	class II
Ambient temperature	Ta=40°C
Protection degree	IP 20
Test voltage	4,2 KV/1'
Terminals	self-lifting screws

### Application:

Single-phase isolating and safety transformers suitable for DIN rail or floor screws installation.

Multi-voltage input and output with protection degree IP20.

Protection class 2









Construction in accordance with the following standards:

### Standard

CEI-EN 61558,2-4 and 2-6 – isolating and safety transformers

IEC 61558,2-4 and 2-6

### Technical data T1L

CODE	RATED POWER	APPROVALS	DIMENSIONS					WEIGHT Kg	LOSSES (W)		EFFICIENCY %	U <sub>cc</sub> %	DV
			A	B	C	D	E		NO-LOAD	LOAD			
T1L-50	50	CE 	89	106	100	68,5	90	1,4	3,5	6,2	84	11,5	11,8
T1L-63	63	CE 	89	106	100	68,5	90	1,5	3,4	8,1	84,7	11,1	11,4
T1L-75	75	CE 	89	106	110	68,5	90	1,8	4,5	8,2	85,7	9,5	9,7
T1L-100	100	CE 	89	106	120	68,5	90	2,1	5,5	10,3	86,3	9,2	9,4
T1L-160	160	CE 	113	115	112	80	99	2,3	5,9	15	87,6	9	9,2
T1L-200	200	CE 	113	115	122	80	99	3	7,1	21,1	87,8	8,9	9,1
T1L-250	250	CE 	113	115	132	80	99	3,5	8,4	26,6	87,9	8,4	8,7
T1L-300	300	CE 	126	136	117	96	121	3,8	8,6	27	89,3	8,3	8,3
T1L-400	400	CE 	126	136	127	96	121	4,5	10,5	34,9	89,9	8,1	8,2



# LV single-phase dry-type transformers

## Single-phase transformer

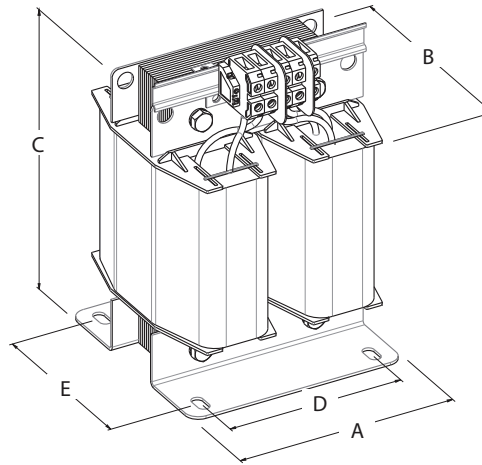

### General data

Rated input voltage	up to 600 V
Rated output voltage	up to 600 V
Rated power	from 5 to 80 KVA
Insulation class	class H
Temperature class	class F

Ambient temperature	Ta=40°C
Protection degree	IP 00 - class I
Test voltage	3 KV/1'
Terminals	terminal blocks / bars

### Application:

Suitable for any industrial applications for electrical isolation of the input and output side.

Construction in accordance with the following standards:

### Standard

CEI-EN 60076 – dry type transformers
IEC -60076 – dry type transformers
UL 5085 1 and 2 – low voltage transformers

### Certifications



Insulation System class F - H (upon request)

### Technical data T2

### Electrical data

CODE	RATED POWER kVA	DIMENSIONS (mm)					WEIGHT Kg	LOSSES (W)		EFFICIENCY %	U <sub>cc</sub> %	ΔV %	INRUSH CURRENT x I <sub>n</sub>
		A	B	C	D	E		no-load	load				
T2-5	5	240	210	330	180	120	32	300	93,5	6,4	5	5	20
T2-8	8	240	230	330	180	140	42	340	95,3	4,8	4,8	4,8	20
T2-10	10	280	230	408	240	130	53	390	95,6	4,8	4	4	18
T2-15	15	280	270	408	235	170	72	95	445	96,5	3,7	3,5	15
T2-20	20	320	280	440	265	320	88	115	530	96	3,6	3,5	15
T2-25	25	320	310	440	265	198	110	140	600	97,1	3,1	3,2	14
T2-30	30	400	330	550	300	200	125	150	890	96,6	4,7	4,6	13
T2-40	40	400	360	550	300	220	155	180	1010	97,1	4,6	4,5	12
T2-50	50	400	410	550	300	240	190	230	1060	97,4	3,9	3,8	10
T2-60	60	400	440	550	300	280	225	280	1080	97,8	3,4	3,4	9
T2-80	80	400	480	550	300	320	275	335	1350	97,9	3,3	3,4	9

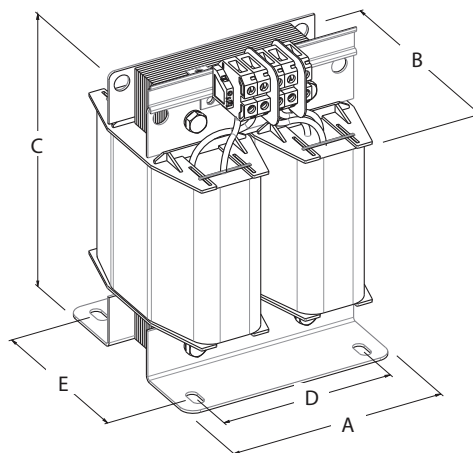
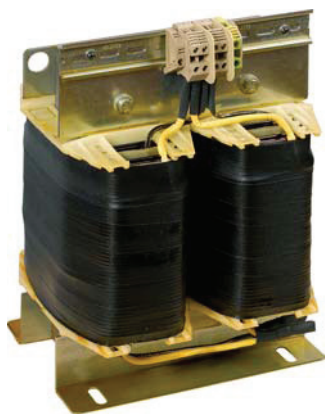

### General data

Rated input voltage	230 V
Rated output voltage	115-0-115 V
Rated power	from 2200 VA to 10kVA
Insulation class	class F-H
Temperature class	class B
Ambient temperature	Ta=40°C
Protection degree	IP 00 - class I
Inrush current	12 x In
Short-circuit voltage	3%

Insulation voltage	5KV/1'
No-load current	3%
Leakage current of the output winding to earth	≤0,5 mA
Leakage current of the enclosure to earth	≤ 3,5 mA
Terminals	terminal blocks
Double screen between primary and secondary	
Equipped with a pocket for PT100 upon request	

### Application:

Suitable for galvanic separation between the net from the users in medical locations.

Construction in accordance with the following standards:

### Standard

CEI-EN 61558, 2-15

IEC 61558, 2-15

**Class F/F version is available upon request**



Isolating transformer for powering medical locations.

### Technical data T2H

CODE	RATED POWER VA	DIMENSIONS (mm)					WEIGHT Kg	LOSSES (W)		EFFICIENCY %	U <sub>cc</sub> %	INRUSH CURRENT x In
		A	B	C	D	E		no-load	load			
T2H-2.2	2200	200	155	300	150	126	36	12	65	96,7	3	12
T2H-3.3	3300	240	175	355	180	104	46	15	90	96,9	3	12
T2H-4	4000	240	185	355	180	114	50	20	110	96,9	3	12
T2H-5.5	5500	280	195	355	180	124	56	25	130	97	3	12
T2H-7.5	7500	280	230	410	235	152	66,5	30	190	97,1	3	12
T2H-10	10000	280	240	410	235	162	75	35	230	97,4	3	12

### Electrical data

Data referred to 230/115-0-115 V

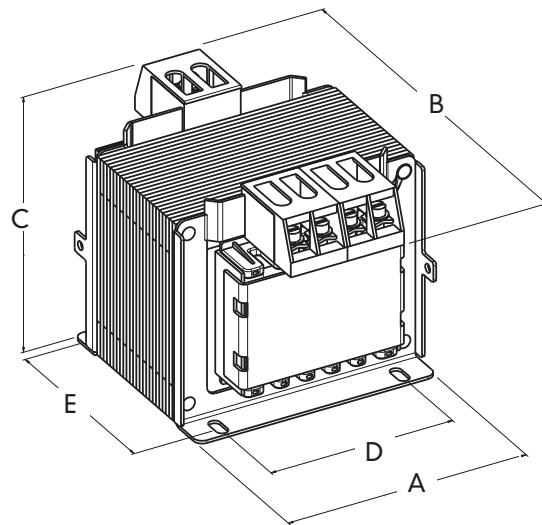

### General data

Rated input voltage	400-440 V
Rated output voltage	24-230 V
Rated power	150-250-400-800-1000 VA
Insulation class	class F self-extinguishing
Temperature class	class F

Ambient temperature	Ta=45°C
Protection degree	IP 00 - class I
Test voltage	4,2 KV/1'
Terminals	terminal blocks

### Application:

Suitable for installation in switchboard and for "Marine" applications with GL approvals.

Self-extinguishing isolating components.

Construction in accordance with the following standards:

### Certifications



German Lloyd n.46566 – 12HH



UL-CSA Listed FILE E169331 (upon request)

### Standard

GL: Guideline for the Performances of Type Approvals Chapter 2 Ed. 2003

## Technical data T1Q-GL

## Electrical data

CODE	RATED POWER VA	APPROVALS	DIMENSIONS (mm)					WEIGHT Kg	LOSSES (W)		EFFICIENCY %	U <sub>cc</sub> %	ΔV %	INRUSH CURRENT x I <sub>n</sub>
			A	B	C	D	E		no-load	load				
T1QGL-150...	150	Ⓞ	96	92	105	84	75	2,6	6,6	12,5	88,9	9,5	8,1	20
T1QGL-250...	250	Ⓞ	121	95	125	90	70	3,6	9,1	17,6	90,5	10	7,2	19
T1QGL-500...	500	Ⓞ	121	135	125	90	110	7	15,6	28,9	91,9	8,5	5,9	20
T1QGL-800...	800	Ⓞ	151	137	140	120	110	9,8	20	46	92,4	5	5	24
T1QGL-1000...	1000	Ⓞ	151	157	140	120	130	12,1	25	47	93,4	4,5	4,5	24



T5



T6



T7

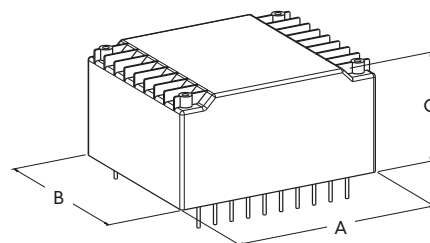
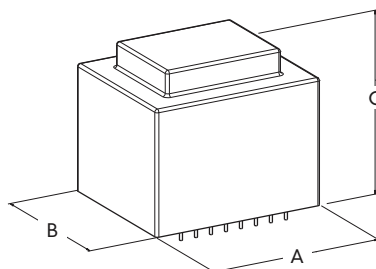
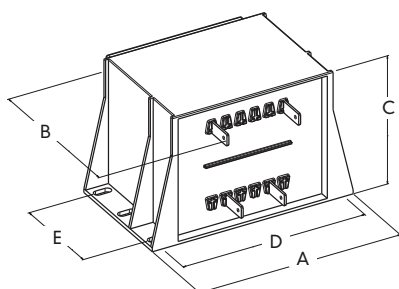

### General data

Rated input voltage	from 100 to 250 V
Rated output voltage	from 12 to 42 V
Rated power	T5: from 12 to 70 VA
	T6: from 3,2 to 100 VA
	T7: from 4 to 60 VA

Insulation class	class B
Temperature class	class B
Ambient temperature	Ta=70°C
Protection degree	IP 00
Test voltage	4,2 KV/1'

### Application:

Safety transformers encapsulated with epoxy resin suitable for PCB use (T6-T7) or use in critical ambients (T5).



- T5: input and output with 6,3 mm faston
- T6: for PCB insertion with pins with  $\varnothing 0,8$  mm
- T7: for PCB low profile with pins with  $\varnothing 0,8$  mm

Construction in accordance with the following standards:

### Standard

CEI-EN 61558, 2-6 – safety transformers
IEC 61558, 2-6 – safety transformers
UL-CSA 5085 1-2 – low voltage transformers

### Certifications

	ENEC-KEMA File: 3502609 03-04-05
	UL Insulation System class B File E215141

### Technical data T5

CODE	RATED POWER	APPROVALS	DIMENSIONS (mm)					WEIGHT	LOSSES (W)		EFFICIENCY	ΔV
	VA		A	B	C	D	E		no-load	%		
T5-12	12		82	48	50	68	11	0,42	1	76	15	
T5-20	20		82	54	54	74	13	0,56	1,2	87	14	
T5-30	30		94	59	60	82	13	0,76	1,5	82	14	
T5-35	35		94	59	71	82	36	1,04	2,2	85	9	
T5-55	55		105	66	73	93	38	1,32	2,7	86	9,9	
T5-70	70		105	66	83	93	48	1,54	3,5	87	8,8	



### Electrical data

### Technical data T6

CODE	RATED POWER	APPROVALS	DIMENSIONS (mm)							WEIGHT	LOSSES (W)		EFFICIENCY	ΔV	FIG.
	VA		A	B	C	D	E	F	G		Kg	no-load			
T6-3,2	3,2		42	35,5	27,5	-	-	5	25	0,16	0,5	69	25	2	
T6-4	4		43	37	33	-	-	5	25	0,18	0,9	69	25	2	
T6-5	5		44,2	37,2	32	-	-	5	25	0,19	1	66	27	2	
T6-10	10		50,2	42,2	34,5	-	-	5	27,5	0,28	1,2	71	24	2	
T6-12	12		50,2	42,2	38,1	-	-	5	27,5	0,32	1,4	73	22	2	
T6-16	16		74	47,5	40	65	-	5	32,5	0,42	1,6	72	24	1	
T6-20	20		81,5	53,7	48	72,5	43,5	5	32,5	0,54	1,9	80	14	1	
T6-25	25		81,5	53,7	53	72,5	43,5	5	32,5	0,62	2,2	81	13	1	
T6-30	30		81,5	53,7	58	72,5	43,5	5	32,5	0,72	2,4	83	12	1	
T6-35	35		87,5	58,6	58	78	48	5	35	0,78	2,6	84	12	1	
T6-50	50		87,5	58,6	68	78	48	5	35	1,05	3,2	85	11	1	
T6-60	60		102	69	65	90	57	7,5	39	1,35	3,4	86	11	1	
T6-100	100		102	69	75	90	57	7,5	39	1,6	4,5	86	13	1	



### Electrical data

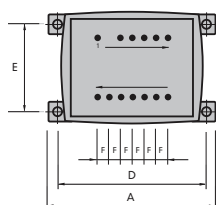

fig. 1

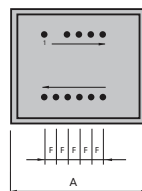
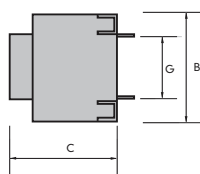
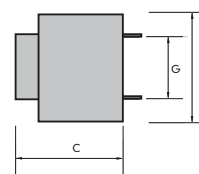

fig. 2



### Technical data T7

CODE	RATED POWER	APPROVALS	DIMENSIONS (mm)			WEIGHT	LOSSES (W)		EFFICIENCY	ΔV	FIG.
	VA		A	B	C (H)		Kg	no-load			
T7-4	4		53	44	17,6	0,16	1,2	55	40	1	
T7-6	6		53	44	22,6	0,18	1,1	63	33	1	
T7-10	10		53	44	28,6	0,19	1,1	70	26	1	
T7-14	14		68	57,5	24,2	0,28	1,6	70	26	2	
T7-18	18		68	57,5	27,2	0,32	1,4	74	23	2	
T7-24	24		68	57,5	31	0,42	1,7	76	21	2	
T7-30	30		68	57,5	35,5	0,54	1,8	78	19	2	
T7-40	40		83,5	69	37	0,62	2,2	78	19	3	
T7-60	60		83,5	69	46	0,72	3,1	78	17	3	



### Electrical data

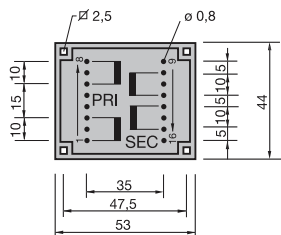

fig. 1

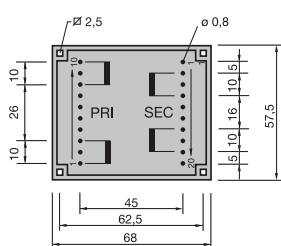

fig. 2

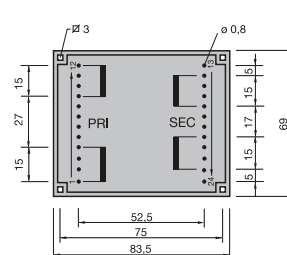
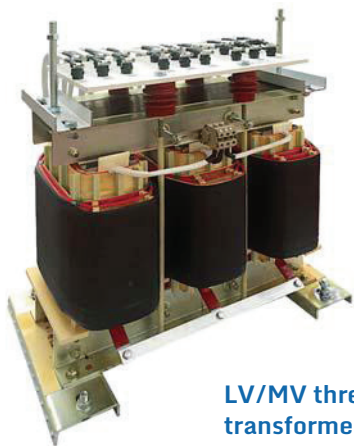

fig. 3

## OTHER TRANSFORMERS



LV/MV three-phase transformers



MV three-phase reactors for short-circuit current



Single-phase transformers with fast-on terminals

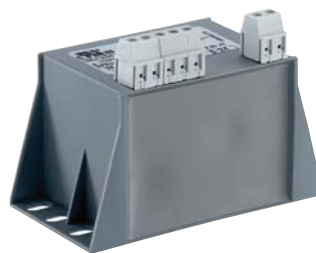

Single-phase transformers with vertical connectors

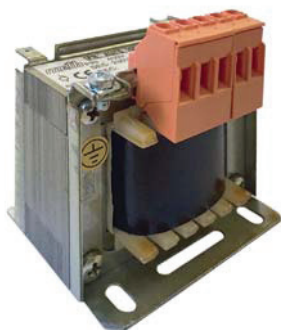

Single-phase auto-transformers



AC/DC multi-voltages power supplier

**36.02 ///**  
**THREE-PHASE**  
**TRANSFORMERS**

[www.meth.it](http://www.meth.it)



T3TULF - T3TUL up to 10 KVA

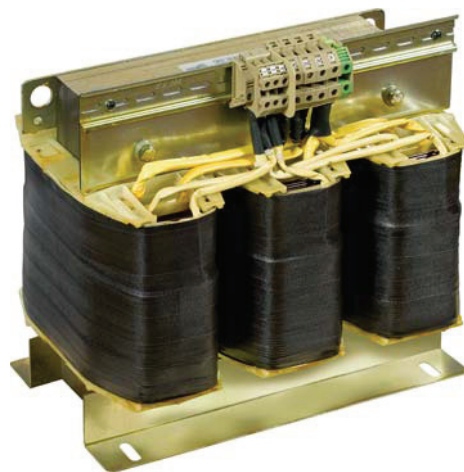

T3TUL - 11-25 KVA



### General data

Rated input voltage	100-600 V
Rated output voltage	10-600 V
Rated power	from 100 to 25kVA
Insulation class	class F
Temperature class	class F

Ambient temperature	Ta=40°C
Protection degree	IP 00
Test voltage	4,2 KV/1'
Terminals	terminal blocks or bars

### Application:

Three-phase transformers UL-CSA marked suitable for any industrial application.



In particular:

- up to 5kVA: UL-CSA Listed marked
  - from 5kVA to 25kVA: UL-CSA – Recognized component marked
- Construction in accordance with the following standards

### Standard

UL 5085 1 and 2 – Low voltage transformers
CSA 22.2 No 66

### Certifications

	(Listed) FILE E169331 vol. 2-sec. 1-2
	(Recognized) File E169331 vol.1 sec. 2
	Insulation System : File 215141 vol.1



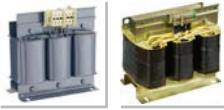

## Technical data T3TULF - T3TUL

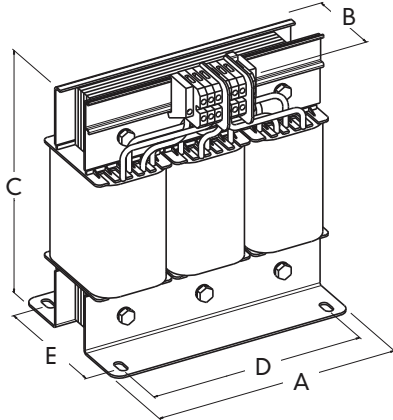

Fig. 1

CODE	RATED POWER	APPROVALS	INSULATION CLASS	DIMENSIONS (mm)					WEIGHT Kg	FIG.
	KVA			A	B	C	D	E		
T3TULF-0,1...	0,1		F	120	75	110	100	50	2,1	1
T3TULF-0,16...	0,16		F	120	85	110	100	60	2,8	1
T3TULF-0,25...	0,25		F	151	95	150	125	60	3,8	1
T3TULF-0,4...	0,4		F	151	110	150	125	75	5,5	1
T3TULF-0,5...	0,5		F	180	120	190	150	72	6,7	1
T3TULF-0,75...	0,75		F	180	140	190	150	92	10,9	1
T3TULF-1...	1		F	240	145	260	200	80	15	1
T3TULF-1,5...	1,5		F	240	155	260	200	90	17,6	1
T3TULF-2...	2		F	240	170	260	200	100	24,8	1
T3TULF-2,5...	2,5		F	240	185	260	200	115	28,1	1
T3TULF-3...	3		F	300	160	315	250	91	33	1
T3TULF-4...	4		F	300	170	315	250	101	39	1
T3TULF-5...	5		F	300	190	315	250	121	49	1
T3TUL-6...	6		F	360	170	365	300	106	58	1
T3TUL-7...	7		F	360	180	365	300	116	62	1
T3TUL-8...	8		F	360	190	365	300	126	66	1
T3TUL-9...	9		F	360	200	365	300	136	69	1
T3TUL-10...	10		F	360	210	365	300	146	75	1
T3TUL-15...	15		F	420	250	450	375	150	89	2
T3TUL-20...	20		F	420	270	450	375	172	110	2
T3TUL-25...	25		F	480	300	450	440	180	125	2

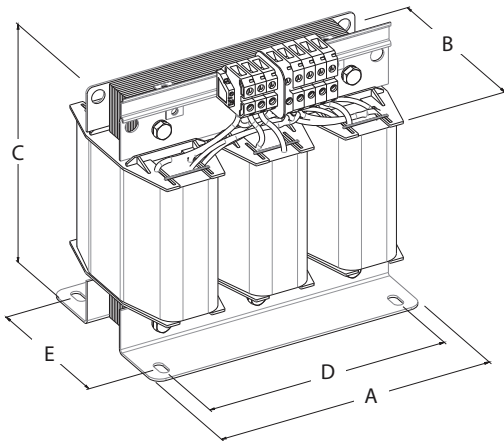
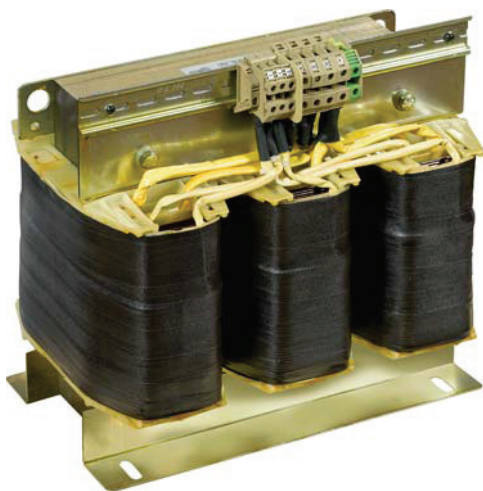

Fig. 2

## Electrical data

	RATED POWER		LOSSES (W)		EFFICIENCY		Ucc %		INRUSH CURRENT
	KVA	no-load	load (75°C)	total	%	Ucc X	Ucc R	Ucc tot	x In
T3TULF	0,1	5	15	20	83	-	-	13,5	24
	0,16	6,5	19,5	26	85,8	-	-	10,9	25
	0,25	7,5	24	31,5	88,4	-	-	9	26
	0,4	11,5	38	49,5	88,6	-	-	8,8	28
	0,5	15	26,5	41,5	92,2	-	-	5,1	28
	0,75	22,5	30	52,5	93,3	-	-	3,9	29
	1	25,8	42	67,8	93,6	-	-	4	20
	1,5	30	64,5	94,5	93,9	-	-	4,2	18
	2	37,5	102	139,5	93,4	-	-	4,8	18
	2,5	46	114	160	93,9	-	-	4,4	16
T3TUL	3	47	129	176	94,3	-	-	4,2	16
	4	58	186	244	94,2	-	-	4,5	16
	5	76	169	245	95,3	-	-	3,4	18
	6	84	300	384	94	-	-	5,2	15
	7	100	285	385	94,7	-	-	4,4	17
	8	110	355	465	94,5	-	-	4,5	16
	9	122	384	506	94,7	-	-	4,3	16
	10	135	387	522	95,06	1,46	4,3	4,55	16
	15	192	440	632	96,22	1,7	3,17	3,6	18
	20	140	570	710	96,78	1,68	2,6	3,1	19
25	160	720	880	96,6	2,77	2,88	4	18	



T3T up to 10 KVA



T3T 11-40 KVA



### General data

Rated input voltage	100-600 V
Rated output voltage	24-600 V
Rated power	up to 25 kVA (safety transformers) up to 40 kVA (isolating transformers)
Insulation class	class F / H
Temperature class	class F / H

Ambient temperature	Ta=40°C
Protection degree	IP 00
Standard vector group	Dyn11 (others upon request)
Test voltage	4,2 KV/1'
Terminals	terminal blocks or bars

### Application:

Three-phase transformers suitable for any industrial application where it is required the separation between the load and the net. Construction in accordance with the following standards:

### Standard

CEI-EN 61558; p. 2-4 – Isolating transformers

CEI-EN 61558; p. 2-6 – Safety transformers

IEC 61558; 2-4; 2-6

### Upon request:

The transformers could be customized with:

- different voltages
- regulations
- taps on primary or secondary
- different enclosures
- wheels for movement
- vibration absorbers
- electrostatic screen between primary and secondary
- temperature control unit with 3PT100 probes inserted



STEEL ENCLOSURE for three-phase transformers pag. 40

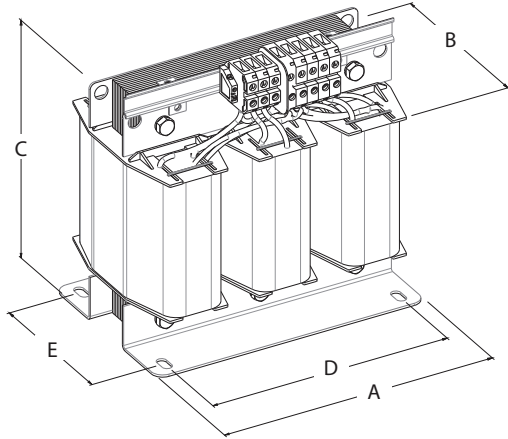
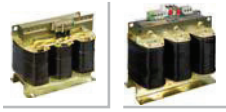

Fig. 1

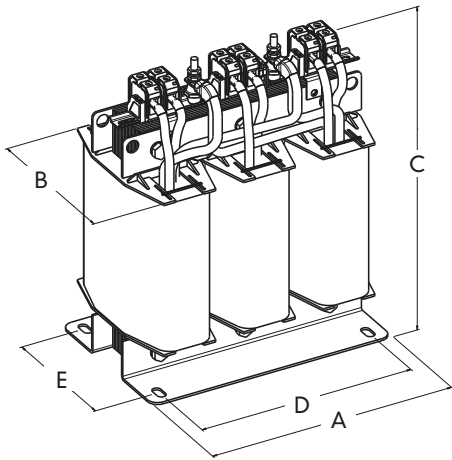

Fig. 2

Technical data T3T

CODE	RATED POWER KVA	INSULATION CLASS	DIMENSIONS (mm)					WEIGHT FIG. BOX		
			A	B	C	D	E	Kg		
T3T-0,1...	0,1	F	120	75	110	100	50	2,1	1	-
T3T-0,16...	0,16	F	120	85	110	100	60	2,8	1	-
T3T-0,25...	0,25	F	151	95	150	125	60	3,8	1	-
T3T-0,4...	0,4	F	151	110	150	125	75	5,5	1	-
T3T-0,5...	0,5	F	180	120	190	150	72	6,7	1	-
T3T-0,75...	0,75	F	180	140	190	150	92	10,9	1	-
T3T-1...	1	F	240	145	260	200	80	15	1	-
T3T-1,5...	1,5	F	240	155	260	200	90	17,6	1	-
T3T-2...	2	F	240	170	260	200	100	24,8	1	-
T3T-2,5...	2,5	F	240	185	260	200	115	28,1	1	-
T3T-3...	3	F	300	160	315	250	91	33	1	...-1
T3T-4...	4	F	300	170	315	250	101	39	1	...-1
T3T-5...	5	F	300	190	315	250	121	49	1	...-1
T3T-6...	6	F	360	170	365	300	106	58	1	...-2
T3T-7...	7	F	360	180	365	300	116	62	1	...-2
T3T-8...	8	F	360	190	365	300	126	66	1	...-2
T3T-9...	9	F	360	200	365	300	136	69	1	...-2
T3T-10...	10	F	360	210	365	300	146	75	1	...-2
T3T-15...	15	F	420	250	420	375	150	89	2	...-3
T3T-20...	20	F	420	270	420	375	172	110	2	...-3
T3T-25...	25	F	480	270	450	440	180	125	2	...-4
T3T-30...	30	F	480	280	450	440	190	145	2	...-4
T3T-40...	40	F	480	315	450	440	220	178	2	...-4

Electrical data

RATED POWER KVA	LOSSES (W)			EFFICIENCY %	Ucc %			INRUSH CURRENT x In
	no-load	load (75°C)	total		Ucc X	Ucc R	Ucc tot	
0,1	5	15	20	83	-	-	13,5	24
0,16	6,5	19,5	26	85,8	-	-	10,9	25
0,25	7,5	24	31,5	88,4	-	-	9	26
0,4	11,5	38	49,5	88,6	-	-	8,8	24
0,5	15	26,5	41,5	92,2	-	-	5,1	22
0,75	22,5	30	52,5	93,3	-	-	3,9	25
1	25,8	42	67,8	93,6	-	-	4	20
1,5	30	64,5	94,5	93,9	-	-	4,2	18
2	37,5	102	139,5	93,4	-	-	4,8	17
2,5	46	114	160	93,9	-	-	4,4	15
3	47	129	176	94,3	-	-	4,2	15
4	58	186	244	94,2	-	-	4,5	15
5	76	169	245	95,3	-	-	3,4	16
6	84	300	384	94	-	-	5,2	14
7	100	285	385	94,7	-	-	4,4	15
8	110	355	465	94,5	-	-	4,5	15
9	122	384	506	94,7	-	-	4,3	15
10	135	387	522	95,06	1,46	4,3	4,55	16
15	192	440	632	96,22	1,7	3,17	3,6	16
20	140	570	710	96,78	1,68	2,6	3,1	16
25	160	720	880	96,6	2,77	2,88	4	18
30	190	800	990	96,81	2,18	2,67	3,45	17
40	235	950	1185	97,12	1,98	2,38	3,1	15



T3T up to 80 KVA



T3T 81-1000 KVA



#### General data

Rated input voltage	up to 1000 V
Rated output voltage	up to 1000 V
Rated power	41 to 1000 kVA
Insulation class	class F / H
Temperature class	class F / H

Ambient temperature	Ta=40°C
Protection degree	IP 00
Standard vector group	Dyn11 (others upon request)
Test voltage	3 KV/1'
Terminals	terminal blocks or bars

#### Application:

Three-phase transformers suitable for any industrial application where it is required the isolation or voltage variation between the load and the net. Construction in accordance with the following standards:

#### Standard

CEI-EN 60076

IEC 60076

#### Upon request:

The transformers could be customized with:

- different voltages
- regulations
- taps on primary or secondary
- different enclosures
- wheels for movement
- vibration absorbers
- electrostatic screen between primary and secondary
- temperature control unit with 3PT100 probes inserted



STEEL ENCLOSURE for three-phase transformers pag. 40

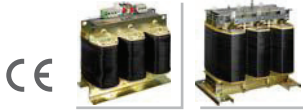

Technical data T3T

CODE	RATED POWER	INSULATION CLASS	DIMENSIONS (mm)					WEIGHT Kg	FIG	BOX
	KVA		A	B	C	D	E			
T3T-50...	50	F	600	350	600	540	250	220	1	...-5
T3T-60...	60	F	600	360	600	540	260	230	1	...-5
T3T-80...	80	F	600	390	600	540	290	280	1	...-5
T3T-100...	100	F	600	420	600	540	320	330	2	...-5
T3T-125...	125	F	720	420	740	660	300	390	2	...-6
T3T-160...	160	F	720	460	740	660	340	510	2	...-6
T3T-200...	200	F	720	480	740	660	360	570	2	...-6
T3T-250	250	F	720	510	740	660	380	660	2	...-6
T3T-315	315	F	720	550	740	660	430	780	2	...-6
T3T-400	400	F	960	630	920	-	-	1090	2	...-7
T3T-500	500	F	960	680	920	-	-	1335	2	...-7
T3T-630	630	F	960	730	920	-	-	1575	2	...-7
T3T-800...	800	F	1080	650	1190	-	-	1670	2	...-8
T3T-1000...	1000	F	1080	700	1190	-	-	2020	2	...-8

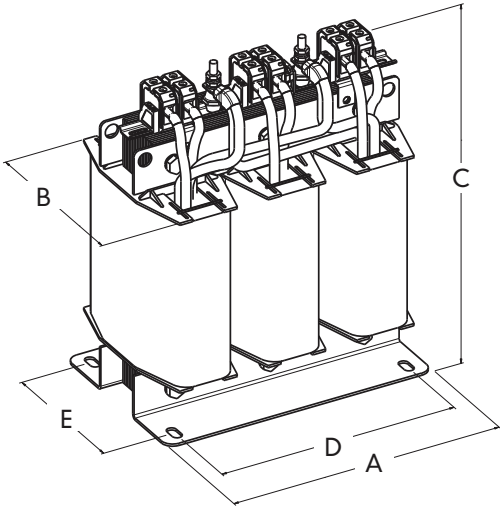

Fig. 1

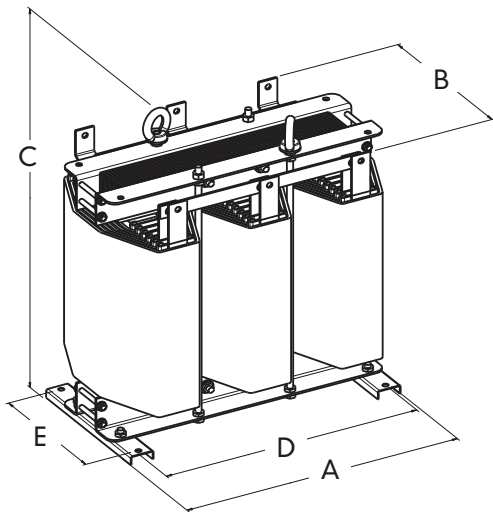

Fig. 2

Electrical data

RATED POWER KVA	LOSSES (W)			EFFICIENCY %	Ucc %			INRUSH CURRENT x In
	no-load	load (75°C)	total		Ucc X	Ucc R	Ucc tot	
50	245	1300	1545	97	4,32	2,6	5,05	18
60	265	1600	1865	96,99	4,4	2,67	5,15	15
80	340	1900	2240	97,28	4,39	2,38	5	15
100	430	2200	2630	97,44	3,75	2,2	4,35	16
125	400	2400	2800	97,81	4,23	1,92	4,65	14
160	520	2800	3320	97,97	3,03	1,75	3,5	14
200	560	3100	3660	98,2	3,46	1,55	3,8	14
250	670	3500	4170	98,36	3,47	1,4	3,75	13
315	840	4000	4840	98,49	3,52	1,27	3,75	14
400	1120	5060	6180	98,5	6,37	1,27	6,5	15
500	1340	5565	6905	98,6	5,34	1,12	5,5	15
630	1650	6780	8430	98,7	4,86	1,08	5	16
800	1760	9150	10910	98,8	5,56	1,15	5,7	8
1000	2100	9250	11350	98,9	4,79	0,93	4,9	8

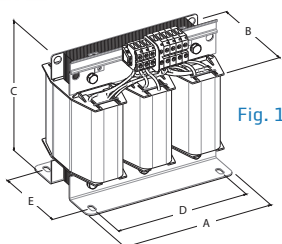
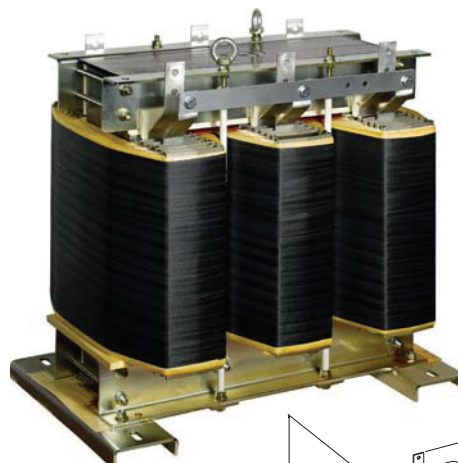
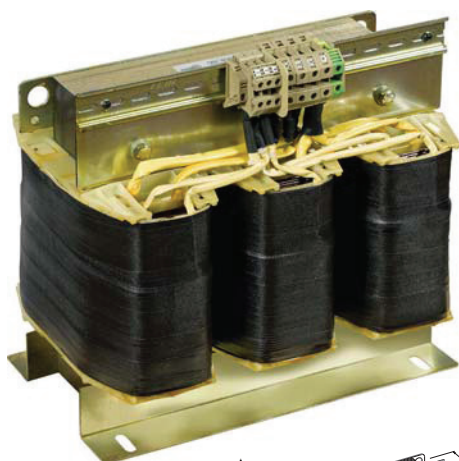

Fig. 1

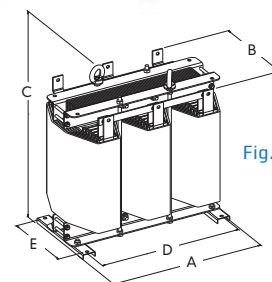

Fig. 2

#### General data

Rated input voltage	up to 1000 V
Rated output voltage	up to 1000 V
Rated power	3 to 80 kVA
Insulation class	class H
Temperature class	class F / H

Ambient temperature	Ta=40°C
Protection degree	IP 00
Standard vector group	Dyn11 (others upon request)
Test voltage	3 KV/1'
Terminals	terminal blocks or bars

#### Application:

Three-phase transformers suitable for any industrial application where it is required the isolation or voltage variation between the load and the net. Suitable for UL labeled industrial control panels according to UL guideline UL 5085. Construction in accordance with the following standards:

#### Standard

CEI-EN 60076
IEC 60076
UL 5085 1 and 2 Low Voltage Transformers
GSA 22.2 No. 66

#### Technical data T3TAH-UL

CODE	RATED POWER KVA	INSULATION CLASS	DIMENSIONS (mm)					WEIGHT Kg	FIG.	LOSSES (W)			EFFICIENCY %	UCC %	INRUSH CURRENT x In
			A	B	C	D	E			no-load	load	total			
T3TAHUL-3...	3	H	300	170	315	250	110	30	1	60	210	270	91,7	5,8	20
T3TAHUL-5...	5	H	300	190	315	250	140	40	1	85	280	365	93,2	5,2	18
T3TAHUL-7,5...	7,5	H	360	200	356	325	150	62	1	115	330	445	94,4	4,6	17
T3TAHUL-10...	10	H	360	230	356	325	180	80	1	125	350	475	95,4	4,2	17
T3TAHUL-15...	15	H	420	250	415	375	170	91	1	125	540	665	95,7	4,2	18
T3TAHUL-20...	20	H	420	270	415	375	200	135	1	205	500	705	96,6	3,7	18
T3TAHUL-25...	25	H	480	300	445	425	190	145	1	190	710	900	96,5	3,5	18
T3TAHUL-30...	30	H	480	320	445	425	210	155	1	210	760	970	96,8	3,4	17
T3TAHUL-35...	35	H	480	340	445	425	230	180	1	235	860	1095	96,9	3,2	17
T3TAHUL-40...	40	H	480	350	445	425	240	190	1-2	250	970	1220	97	3,2	17
T3TAHUL-45...	45	H	600	350	600	540	220	200	1-2	250	1430	1680	96,5	4,8	10
T3TAHUL-50...	50	H	600	360	600	540	230	220	1-2	270	1480	1750	96,6	5,5	9
T3TAHUL-60...	60	H	600	380	600	540	250	250	1-2	320	1565	1885	97	4,7	9
T3TAHUL-70...	70	H	600	390	600	540	260	270	1-2	340	1830	2170	97	4,9	9
T3TAHUL-80...	80	H	600	410	600	540	280	305	1-2	390	1950	2340	97,2	4,6	9

#### Electrical data

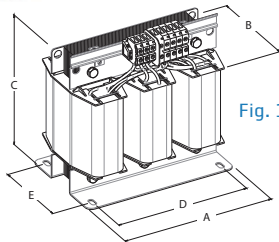
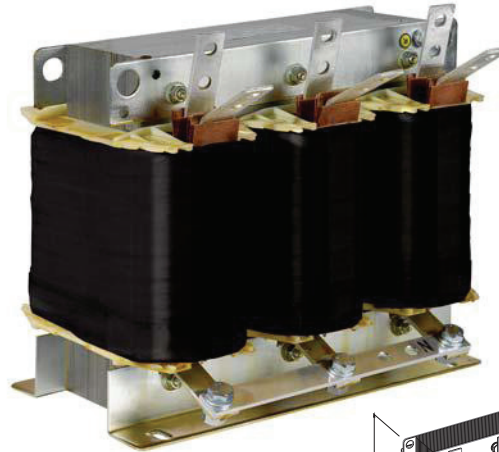
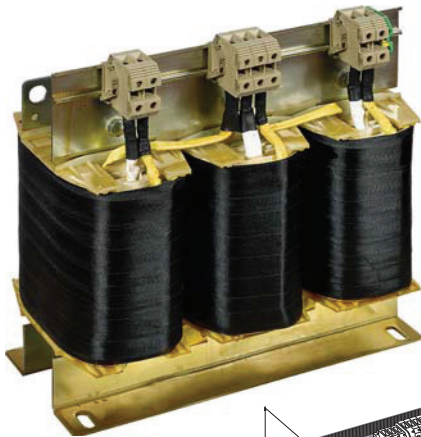

Fig. 1

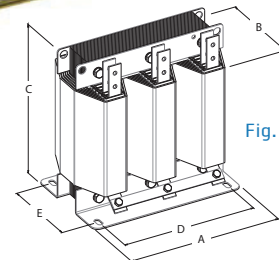

Fig. 2



**General data**

Three-phase auto-transformers are electrical machine with one single common wiring where primary and secondary are not galvanically separated. They have smaller construction compared to the same isolating transformers.

Typical applications are speed control for Fans, Starting of big three-phase Electric Motors, etc... Auto-transformers do not protect from earth failure. Their special feature is that the nearer are the values of the input and output voltage, the more cost-effective are auto-transformers. It is clear that auto-transformers should be calculated and designed every time, based on customer requests, since the input and output voltages are critical to determine the correct electrical sizing. Construction in accordance with the following standards:

**Standard**

CEI-EN 61558; p. 2-13

UL 5058 1-2 up to 345Amps (generally equivalent to 250kVA of nominal power and core power up to 80kVA)

The design rating power could be calculated by the following formula:

$$\text{Design rating} = P_{nom} \left( 1 - \frac{V_1}{V_2} \right)$$

where:

- P<sub>nom</sub> = rated power (VA)
- V<sub>1</sub> = lower voltage (V)
- V<sub>2</sub> = higher voltage(V)

Example:

- P<sub>nom</sub> = 100 kVA
- V<sub>1</sub> = 380 V
- V<sub>2</sub> = 480 V

$$\text{Design rating} = 100 \times \left( 1 - \frac{380}{480} \right) = 21 \text{ kVA}$$

In this case technical data are referred to AT3TH-UL-20kVA

**Technical data AT3TH-UL**

CODE	DESIGN RATING KVA	INSULATION CLASS	DIMENSIONS (mm)					WEIGHT Kg	FIG.	LOSSES (W)			EFFICIENCY %	UCC %	INRUSH CURRENT x In
			A	B	C	D	E			no-load	load	TOTAL			
AT3TH-UL-...	3	H	300	170	315	250	110	30	1	60	210	270	91,7	5,8	20
	5	H	300	190	315	250	140	40	1	85	280	365	93,2	5,2	18
	7,5	H	360	200	356	325	150	62	1	115	330	445	94,4	4,6	17
	10	H	360	230	356	325	180	80	1	125	350	475	95,4	4,2	17
	15	H	420	250	415	375	170	91	1	125	540	665	95,7	4,2	18
	20	H	420	270	415	375	200	135	1	205	500	705	96,6	3,7	18
	25	H	480	300	445	425	190	145	1	190	710	900	96,5	3,5	18
	30	H	480	320	445	425	210	155	1	210	760	970	96,8	3,4	17
	35	H	480	340	445	425	230	180	1	235	860	1095	96,9	3,2	17
	40	H	480	350	445	425	240	190	2	250	970	1220	97	3,2	17
	45	H	600	350	600	540	220	200	2	250	1430	1680	96,5	4,8	10
	50	H	600	360	600	540	230	220	2	270	1480	1750	96,6	5,5	9
	60	H	600	380	600	540	250	250	2	320	1565	1885	97	4,7	9
	70	H	600	390	600	540	260	270	2	340	1830	2170	97	4,9	9
80	H	600	410	600	540	280	305	2	390	1950	2340	97,2	4,6	9	

**Electrical data**

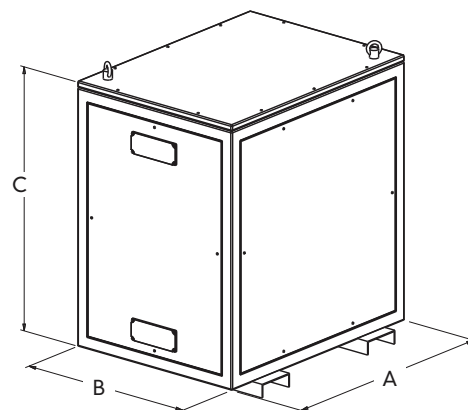

### General data

Rated input voltage	up to 1000 V	Ambient temperature	Ta=40°C
Rated output voltage	up to 1000 V	Protection degree	with enclosure IP55
Rated power	10 to 300 kVA	Standard vector group	Dyn11 (others upon request)
Insulation class	class F-H	Test voltage	3 KV/1'
Temperature class	class F	Terminals	terminal blocks or bars

### Application:

Three-phase transformers suitable for any industrial application where the protection degree IP55 is required. The enclosure is pre-galvanized steel painted with polyester resin for external without fan ventilation. Construction in accordance with the following standards:

### Standard

CEI-EN 60076
IEC 60076

For higher power please contact METH

### Technical data T3X

### Electrical data

CODE	RATED POWER KVA	INSULATION CLASS	DIMENSIONS (mm)			WEIGHT Kg	LOSSES (W)			EFFICIENCY %	Ucc X %	Ucc R %	Ucc tot %	INRUSH CURRENT x In
			A	B	C		no-load	load (75°C)	total					
T3X-10...	10	F	750	650	850	200	150	200	350	96,6	1,67	2	2,6	21
T3X-15...	15	F	850	700	850	220	170	280	450	97	1,16	1,87	2,2	19
T3X-20...	20	F	850	700	950	240	190	350	540	97,3	1,65	1,75	2,4	20
T3X-25...	25	F	850	700	950	270	250	410	660	97,4	1,32	1,64	2,1	17
T3X-30...	30	F	850	700	950	290	280	460	740	97,5	1,28	1,54	2	18
T3X-40...	40	F	1000	850	1100	320	300	650	950	97,6	2,99	1,63	3,4	15
T3X-50...	50	F	1000	850	1100	345	350	850	1200	97,6	2,72	1,7	3,2	14
T3X-60...	60	F	1000	850	1100	380	420	1000	1420	97,6	2,25	1,67	2,8	14
T3X-80...	80	F	1000	850	1100	460	500	1250	1750	97,8	2,2	1,57	2,7	13
T3X-100...	100	F	1200	1000	1300	610	550	1300	1850	98,1	2,14	1,3	2,5	11
T3X-125...	125	F	1200	1000	1300	680	600	1500	2100	98,3	2,08	1,2	2,4	10
T3X-160...	160	F	1200	1000	1300	770	700	1800	2500	98,4	2,24	1,13	2,5	10
T3X-200...	200	F	1200	1000	1360	990	900	2000	2900	98,5	2,19	1	2,4	9
T3X-300...	300	F	1600	1200	1550	1250	1000	2530	3530	98,8	4,14	0,85	4,2	9



LOW-LOSSES three-phase SLIM-LINE transformers  
ECO-DESIGN Three-phase transformer

T3SL

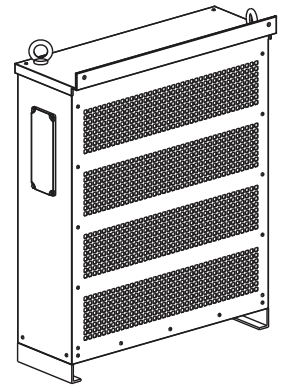
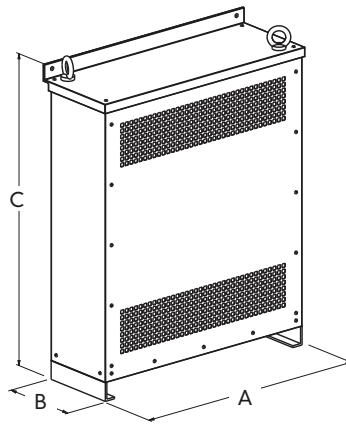

CE

ECO-DESIGN

General data

Standard input voltage	230 V
Standard output voltage	400 V
Rated power	from 6,3 to 30 kVA
Insulation class	class F-H
Temperature class	class B
Standard ambient temperature	Ta=40°C

Protection degree	IP20
Standard vector group	YNd11 (others upon request)
Inrush current	≤10 x In
Test voltage	4,2 KV/1'
Terminals	terminal blocks

Application:

Three-phase transformers designed for maximum utilization of the transformer design. They have very low losses and inrush current, high efficiency and very compact construction in order to save space and reduce energy consumption. Construction in accordance with the following standards:

Standard

EN 61558, p.2-4 and directive 2009/125/EC

Technical data T3SL

Electrical data

CODE	RATED POWER KVA	DIMENSIONS (mm)			WEIGHT Kg	LOSSES (W)		I sec A	EFFICIENCY %	Ucc X %	Ucc R %	Ucc tot %	INRUSH CURRENT x In
		A	B	C		no-load	load (75°C)						
T3SL-6,3...	6,3	640	220	800	115	31	153	9,1	97,1	2,72	2,8	3,65	7
T3SL-10...	10	640	220	800	135	40	240	14,4	97,2	3,48	2,73	4,24	7
T3SL-12,5...	12,5	640	220	800	150	48	295	18,1	97,3	2,14	2,7	3,21	9
T3SL-16...	16	640	220	800	175	64	315	23,1	97,7	1,77	2,3	2,65	10
T3SL-18...	18	640	220	800	195	64	385	26	97,8	2,56	2,2	3,19	9
T3SL-20...	20	790	240	1050	205	60	514	29	97,2	4,54	2,9	5,22	7
T3SL-25...	25	790	240	1050	230	83	495	36,1	97,7	3,64	2,3	4,15	8
T3SL-30...	30	790	240	1050	245	88	620	43,3	97,7	3,7	2,3	4,22	8



T3TFTV UP TO 60 Kva



T3TFTV 61-250 Kva



**General data**

Standard input voltage	400 V
Standard output voltage	400 V
Rated power	from 10 to 250 kVA
Insulation class	class F-H
Temperature class	class B
Standard ambient temperature	Ta=40°C

Protection degree	IP 00
Standard vector group	YNyn0 (others upon request)
Test voltage	3 KV/1'
Terminals	terminal blocks or bars
Terminals	terminal blocks or bars

**Application:**

Three-phase transformers with low losses and high performance suitable for galvanic separation in photovoltaic plants or other renewable energies. Construction is accordance with the following standards:

**Standard**

CEI-EN 60076

IEC 60076



STEEL ENCLOSURE for three-phase transformers pag. 40

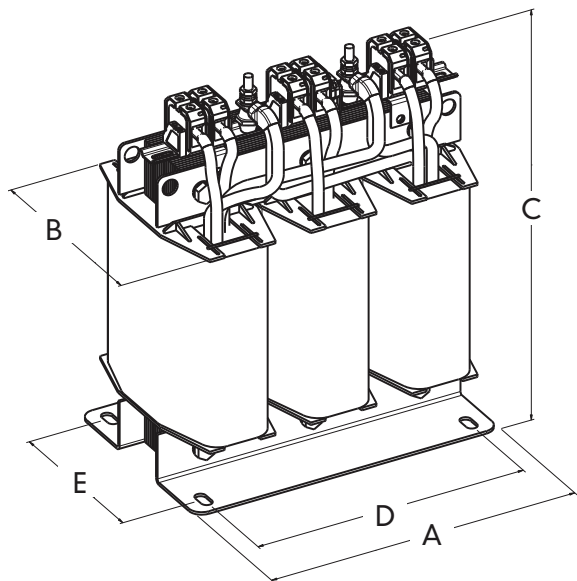

T3TFTV UP TO 60 Kva

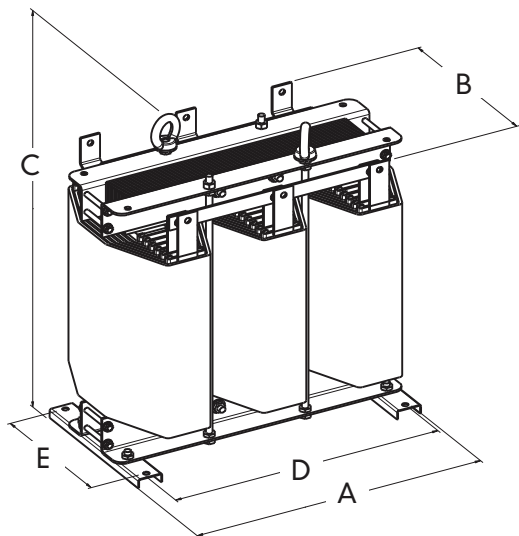

T3TFTV 61-250 Kva

## Technical data T3TFTV UP TO 60 Kva

CODE	RATED POWER	APPROVALS	INSULATION CLASS	DIMENSIONS (mm)					WEIGHT	BOX
	KVA			A	B	C	D	E		
T3TFTV-10	10	B	420	210	390	375	160	90	...-3	
T3TFTV-15	15	B	420	240	390	375	190	120	...-3	
T3TFTV-20	20	B	480	260	450	440	200	140	...-4	
T3TFTV-25	25	B	480	280	450	440	220	160	...-4	
T3TFTV-30	30	B	480	300	450	440	240	190	...-4	
T3TFTV-40	40	B	600	350	600	540	250	220	...-5	
T3TFTV-50	50	B	600	360	600	540	260	230	...-5	
T3TFTV-60	60	B	600	380	600	540	280	260	...-5	

## Technical data T3TFTV UP TO 61-250 Kva

CODE	RATED POWER	APPROVALS	INSULATION CLASS	DIMENSIONS (mm)					WEIGHT	BOX
	KVA			A	B	C	D	E		
T3TFTV-70	70	B	600	390	600	540	290	280	...-5	
T3TFTV-80	80	B	600	420	600	540	320	330	...-5	
T3TFTV-90	90	B	600	450	600	540	350	390	...-5	
T3TFTV-100	100	B	720	420	740	660	300	390	...-6	
T3TFTV-125	125	B	720	430	740	660	310	425	...-6	
T3TFTV-135	135	B	720	440	740	660	320	465	...-6	
T3TFTV-150	150	B	720	460	740	660	340	510	...-6	
T3TFTV-170	170	B	720	480	740	660	360	565	...-6	
T3TFTV-200	200	B	720	500	740	660	380	640	...-6	
T3TFTV-250	250	B	720	550	740	660	430	775	...-6	

## Electrical data - Data referred to 400/400 V

RATED POWER	LOSSES (W)			EFFICIENCY	U <sub>cc</sub>	INRUSH CURRENT
	KVA	no-load	load (75°C)			
10	80	345	425	95,94	3,66	17
15	105	415	520	96,66	3,13	16
20	130	530	660	96,84	3,37	15
25	150	655	805	96,89	3,29	15
30	180	680	860	97,23	2,88	15
40	175	1060	1235	97,01	5,78	14
50	190	1285	1475	97,15	4,09	12
60	225	115	340	97,76	3,29	13
70	240	1335	1575	97,8	3,4	12
80	290	15005	15295	97,81	3,22	14
90	360	1360	1720	98,13	2,63	15
100	380	1780	2160	97,89	4,04	12
125	430	2080	2510	98,04	4,14	10
135	455	2220	2675	98,06	4,18	10
150	510	2140	2650	98,27	3,54	10
170	565	2390	2955	98,29	3,31	9
200	655	2470	3125	98,46	3,23	9
250	815	2970	3785	98,51	2,79	10



## MOTOR STARTING WITH THREE-PHASE AUTO-TRANSFORMERS

Taps: 65% - 70% - 75%

$V_n = 400V$

5 startings/hour – 2 consecutive

Motor  $\cos\phi = 0,85$  Power factor = 0,9

### Technical data

KW	DIMENSIONS (mm)	WEIGHT Kg
20	300x120x275 (H)	28
50	360x130x330 (H)	43
75	360x150x330 (H)	56
100	360x180x330 (H)	68
200	420x210x385 (H)	112
300	480x240x440 (H)	150
400	480x270x440 (H)	185
500	600x250x550 (H)	206

## MOTOR STARTING WITH THREE-PHASE REACTORS

70%  $V_n$

$V_n = 400V$

Motor  $\cos\phi = 0,85$  Power factor = 0,9

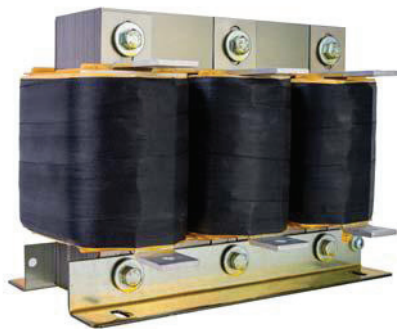

### Technical data

HP	KW	DIMENSIONS (mm)	WEIGHT Kg
20	15	180x80x165 (H)	10
30	22	180x90x165 (H)	13
50	37	240x90x220 (H)	20
75	55	240x110x220 (H)	27
100	74	300x100x275 (H)	36
150	110	300x120x275 (H)	47
200	147	360x120x330 (H)	64
300	220	360x140x330 (H)	78
400	295	420x250x385 (H)	136
500	368	480x270x440 (H)	180

**These devices help three-phase induction motors starting decreasing the supply voltage and the current. Once the starting is effective, the devices are switched off and the three-phase motor will work with net current.**

Meth manufactures a wide range of single- and three-phase reactors.

## MAIN APPLICATIONS OF REACTORS

### R3F THREE-PHASE PFC FILTER REACTORS

The insertion of capacitors banks in presence of harmonics causes a current absorption harmful for life time of capacitors.

Reactors connected in series with the capacitors guarantee:

- Reduction of harmonics
- Reduction of current and consequent reduction of capacitor overheating
- Increase of capacitors life time

### R3L/M THREE-PHASE SMOOTHING REACTORS FOR VARIABLE SPEED DRIVES (MOTOR SIDE)

Inverter Drives produce big quantity of harmful harmonics, which can damage of motor insulation and shorten its life time. Installing a choke between the drive and the motor allows to:

- Reduce the harmonics, improving waveform linearity
- Increase the life time of semiconductors
- Reduce the motor operating temperature
- Reduce the audible equipment noise
- Limit the short circuit current

### R3L/R THREE-PHASE SMOOTHING REACTORS FOR VARIABLE SPEED DRIVES (GRID SIDE)

Inverter Drives not only can damage the motor. Harmonics can penetrate into the electrical net and cause some problems to other electronic or electrical equipment.

Installing a choke between the drive and the electrical net allows to:

- Reduce the harmonics, improving waveform linearity
- Reduce interferences in the electrical net
- Increase the life time of semiconductors

## REACTORS CONSTRUCTION AND MATERIALS

- Windings in copper wire class 200°C or Aluminium
- Windings in copper wire class 200°C
- Magnetic cores from steel with reduced losses and necessary cuts.
- Double impregnation with Polyester resin for safety fixing and with oven dried varnish for protection against external agents.
- Terminals:
  - up to 20A with terminal board IP20
  - up to 90A, with lug terminals
  - over 90A with copper
- Insulation system approved by UL-CSA class F – File E215141
- EN 61558 , p.2-20
- IEC 61558
- UL 5085, p.1-2

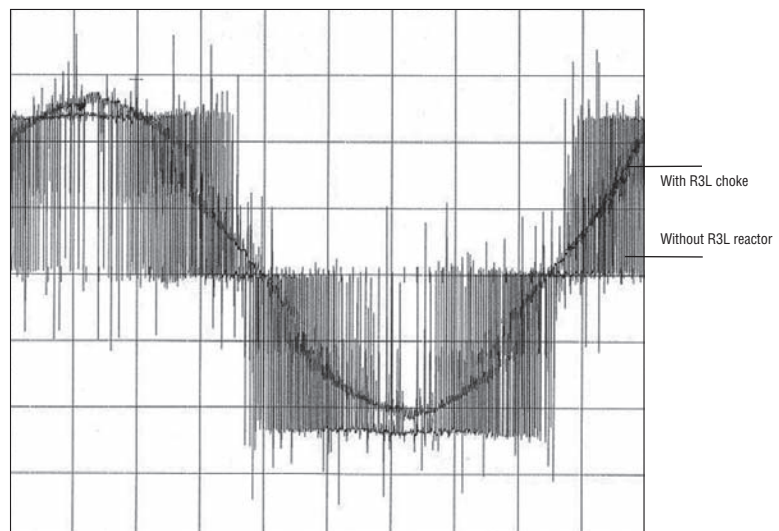
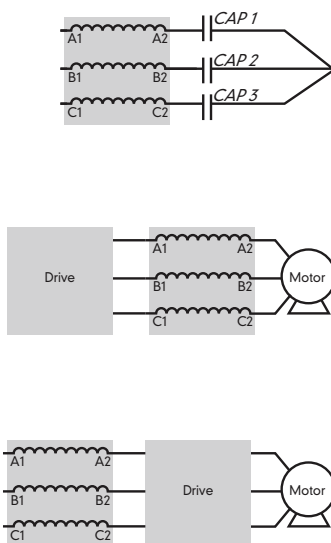

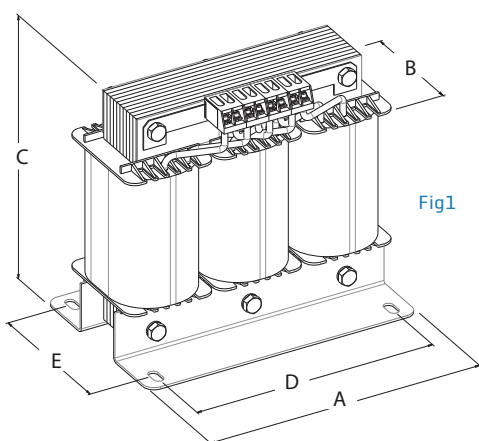

Fig1

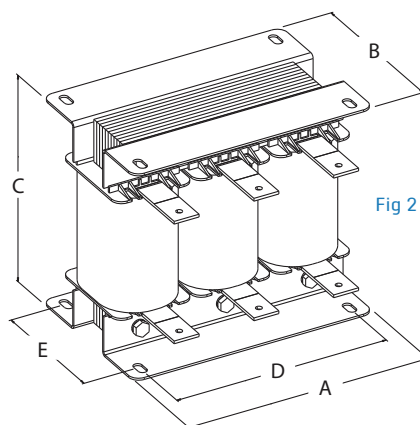

Fig 2



## HARMONIC FILTER REACTOR: 400V - P=7% - 189Hz - 50Hz - LINEARITY > 1,73xI rms

### Electrical data R3F-7

### Technical data

CODE	RATED POWER	INDUCTANCE	I <sub>1</sub>	I rms	LOSSES	DIMENSIONS (mm)					WEIGHT	TERMINAL	CLAMP SIZE	FIG
	KVAR					mH	A	A	W	A				
R3F-7-400-6,25	6,25	6,13	9,56	10,2	35	150	85	140	125	65	6	SCREW	2,5 sqmm	1
R3F-7-400-10	10	3,84	15,3	16,32	50	180	102	173	150	80	8	SCREW	6 sqmm	1
R3F-7-400-12,5	12,5	3,07	19,13	20,4	56	180	113	173	150	90	9	SCREW	6 sqmm	1
R3F-7-400-20	20	1,92	30,5	33,6	67	280	150	187	225	85	13	BUSBAR	M6 FLAT	2
R3F-7-400-25	25	1,53	38,3	40,8	78	280	160	187	225	95	17	BUSBAR	M6 FLAT	2
R3F-7-400-40	40	0,96	61,3	65,4	100	280	170	205	225	105	21	BUSBAR	M8 FLAT	2
R3F-7-400-50	50	0,77	76,6	81,7	120	280	195	205	225	120	26	BUSBAR	M8 FLAT	2

## HARMONIC FILTER REACTOR: 400V - P=14% - 134Hz - 50Hz - LINEARITY > 1,37xI rms

### Electrical data R3F-14

### Technical data

CODE	RATED POWER	INDUCTANCE	I <sub>1</sub>	I rms	LOSSES	DIMENSIONS (mm)					WEIGHT	TERMINAL	CLAMP SIZE	FIG
	KVAR					mH	A	A	W	A				
R3F-14-400-6,25	6,25	13,27	9,56	10,2	55	180	117	173	150	95	10	SCREW	6 sqmm	1
R3F-14-400-10	10	8,29	15,3	16,32	65	280	155	187	225	95	15	BUSBAR	M6 FLAT	2
R3F-14-400-12,5	12,5	6,63	19,13	20,4	78	280	155	187	225	95	17	BUSBAR	M6 FLAT	2
R3F-14-400-20	20	4,15	30,5	33,6	113	280	195	205	225	120	24	BUSBAR	M6 FLAT	2
R3F-14-400-25	25	3,32	38,3	40,8	117	280	200	205	225	125	27	BUSBAR	M6 FLAT	2
R3F-14-400-40	40	2,07	61,3	65,4	168	360	190	255	275	120	40	BUSBAR	M8 FLAT	2
R3F-14-400-50	50	1,66	76,6	81,7	182	360	200	255	275	130	46	BUSBAR	M8 FLAT	2

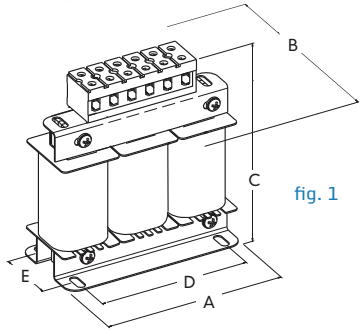

fig. 1

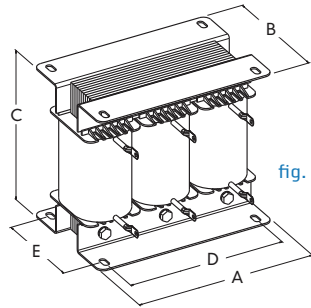

fig. 2

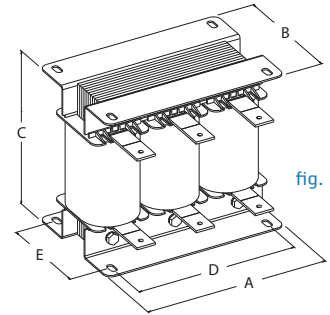

fig. 3



motor SIDE  $\Delta V$  2%  $I_{sat} = 1,5 I_n$  400V 50Hz

Electrical data R3L/M

Technical data

CODE	RATED VOLTAGE	cdt	INDUCTANCE	RATED CURRENT	$I_{sat}/I_n$	DIMENSIONS (mm)			WEIGHT	WINDING	FIG.
	V					%	mH	A			
R3L/15-M	400	2	0,981	15	1,5	150	60	138	4	Cu	fig. 1
R3L/20-M	400	2	0,735	20	1,5	150	65	138	5	Cu	fig. 1
R3L/30-M	400	2	0,49	30	1,5	180	60	165	6	Cu	fig. 1
R3L/50-M	400	2	0,294	50	1,5	180	70	165	8	Al	fig. 1
R3L/75-M	400	2	0,196	75	1,5	180	80	165	10	Al	fig. 2
R3L/100-M	400	2	0,147	100	1,5	240	80	165	12	Al	fig. 2
R3L/125-M	400	2	0,118	125	1,5	240	90	220	14	Al	fig. 2
R3L/150-M	400	2	0,098	150	1,5	240	100	220	16	Al	fig. 3
R3L/200-M	400	2	0,074	200	1,5	240	110	220	19	Al	fig. 3
R3L/250-M	400	2	0,059	250	1,5	300	100	280	24	Al	fig. 3
R3L/300-M	400	2	0,049	300	1,5	300	110	280	28	Al	fig. 3
R3L/350-M	400	2	0,042	350	1,5	300	120	280	29	Al	fig. 3
R3L/400-M	400	2	0,037	400	1,5	300	130	280	34	Al	fig. 3
R3L/500-M	400	2	0,029	500	1,5	360	130	330	42	Al	fig. 3

GRID SIDE  $\Delta V$  4%  $I_{sat} = 1,5 I_n$  400V 50Hz

Electrical data R3L/R

Technical data

CODE	RATED VOLTAGE	cdt	INDUCTANCE	RATED CURRENT	$I_{sat}/I_n$	DIMENSIONS (mm)			WEIGHT	WINDING	FIG.
	V					%	mH	A			
R3L/15-R	400	4	1,961	15	1,5	180	90	155	6	Cu	fig. 1
R3L/20-R	400	4	1,471	20	1,5	180	100	155	8	Cu	fig. 1
R3L/30-R	400	4	0,981	30	1,5	180	110	155	10	Cu	fig. 1
R3L/50-R	400	4	0,588	50	1,5	240	120	210	12	Al	fig. 1
R3L/75-R	400	4	0,392	75	1,5	240	130	210	15	Al	fig. 2
R3L/100-R	400	4	0,294	100	1,5	240	140	210	18	Al	fig. 2
R3L/125-R	400	4	0,235	125	1,5	300	150	260	24	Al	fig. 2
R3L/150-R	400	4	0,196	150	1,5	300	160	260	29	Al	fig. 2
R3L/200-R	400	4	0,147	200	1,5	300	170	260	34	Al	fig. 3
R3L/250-R	400	4	0,118	250	1,5	300	180	260	40	Al	fig. 3
R3L/300-R	400	4	0,098	300	1,5	360	190	310	49	Al	fig. 3
R3L/350-R	400	4	0,084	350	1,5	360	200	310	57	Al	fig. 3
R3L/400-R	400	4	0,074	400	1,5	360	230	350	62	Al	fig. 3
R3L/500-R	400	4	0,059	500	1,5	360	240	350	68	Al	fig. 3

Reactors with  $I_{sat}=2 I_n$  or  $I_{sat}=3 I_n$  are also available. Please contact Meth.



IP23

**Standard enclosure**

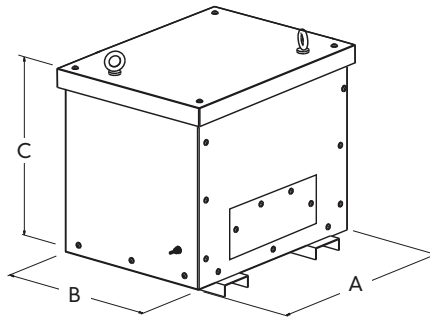

**Technical data IP23**

CODE	DIMENSIONS (mm)			WEIGHT Kg
	A	B	C	
BOX23-1/-2	580	500	500	30
BOX23-3	640	550	560	35
BOX23-4	740	650	700	45
BOX23-5	860	750	820	65
BOX23-6	1100	950	1040	95
BOX23-7	1600	1000	1400	150
BOX23-8	1710	1200	1500	170

**Technical details:**

- 15/10 (box 23-1/2-3-4-5) or 20/10 (box 23-6-7-8) pre-galvanized steel painted with polyester resin
- eye bolts for lifting. From size 23-3 also bottom housing for fork lift or trans pallet lifting
- 2 output metallic plates for cable glands on the same side
- enclosure color: RAL7035



IP21

**Upon request enclosure**

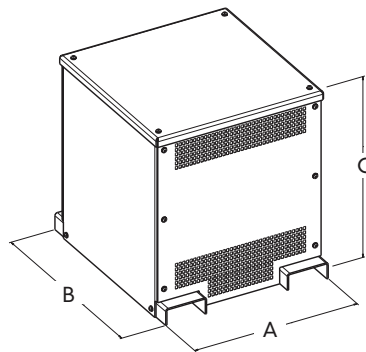

**Technical data IP21**

CODE	DIMENSIONS (mm)			WEIGHT Kg
	A	B	C	
BOX21-1	400	410	550	25
BOX21-2	530	480	580	30
BOX21-3	640	520	650	35
BOX21-4	700	540	650	45
BOX21-5	800	700	800	55
BOX21-6	1040	1000	1150	80

**Technical details:**

- epoxy resin painted steel
- internal eye bolts or bottom housing for fork lift or trans pallet lifting
- 2 output metallic plates for cable glands on the same side
- enclosure color: RAL7032



IP55

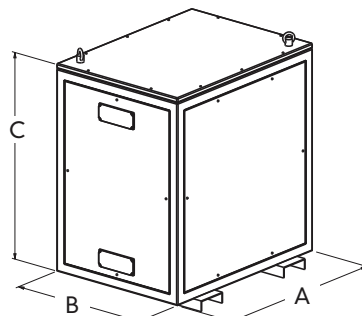

**Technical data IP55**

CODE	DIMENSIONS (mm)			WEIGHT Kg
	A	B	C	
BOX55-1	750	650	850	65
BOX55-2	850	700	950	75
BOX55-3	1000	850	1100	90
BOX55-4	1200	1000	1300	110

**Technical details:**

- pre-galvanized steel painted with polyester resin for external
- eye bolts for lifting
- 2 output plastic cable glands on the same side
- enclosure color: RAL7035



## Indications:

the following technical information are a guideline for the correct use of transformers in various voltage fields. The differences in the construction of the transformers are determined by the installation and equipment requirements. We summarize here the main definitions set down in EN 61558.1 and part 2 standard. Other standards which we refer to are: CEI 14-5, 14-8, EN 60076-1 (power transformers), UL 5085-1-2-3.

## Transformers

**Isolating transformer:** suitable for limiting risks caused by contact between the earth and the live parts that can give an electric shock if the isolation is broken or damaged.

**Primary voltage:** 1000V max - Secondary voltage: 500V no-load - Frequency: 500Hz max - Rated power: 25kVA if single-phase, max. 40kVA if three-phase. Type of isolating: double or reinforced.

**Safety transformer:** isolating transformer suitable for feed circuits of low safety voltage. Primary voltage: 1000V max - Secondary voltage: 50V max. no-load - frequency 500Hz - Rated power: 10kVA if single-phase, max. 16kVA if three-phase. Type of isolating: double or reinforced.

## Rated Ambient Temperature:

this is the temperature surrounding the transformer. If not otherwise specified, the rated ambient temperature is 40°C. Particular care should be taken when the temperature is higher. It should not exceed the values laid down in the table below. The core power must be adapted to approximately the values given below:

Rated Ambient Temperature	Rated power x factor
40 °C	1
50 °C	0.92
60 °C	0.84
70 °C	0.75

**Over-temperature:** this is the temperature which is verified in the transformer when it is working normally. In particular, in the windings, depending on the type of isolating materials and the rated ambient temperature, the following values must not be exceeded:

Maximum excessive temperatures for winding with  $t_a=40^\circ\text{C}$   
 A=60 °C - E=75 °C - B=80 °C - F=100 °C - H=125 °C

**Rated Input Voltage:** network voltage feed of the transformer. Unless otherwise agreed, the maximum limit displayed is a value of 1.1 times the rated input voltage, as long as it does not cause damage to the continuous running of the transformer.

**No-load Current:** this is the input current of the no-load transformer with rated input voltage and frequency. The value of the no-load current is mainly effected by the properties of the used magnetic core laminations and can oscillate, even between transformers from the same production due to practical effects. An oscillation of - 10%/+20% with respect to the rated value is acceptable.

## Protection Class:

the equipment has built-in safety to protect against dangerous electrical currents.

**Class I:** all the metallic parts accessible from the transformer are insulated from the voltage parts by basic insulation and added safety measures consisting of a safety conductor within the electrical system of the installation.

**Class II:** all the metallic parts accessible from the transformers are separated from the voltage parts with double or reinforced isolating. The transformer must not be connected to the earth.

## Insulation Class:

Max insulation system temperature	Max temperature on winding with $T_a=40^\circ\text{C}$
A (105 °C)	60°C
E (120 °C)	75°C
B (130 °C)	80°C
F (155 °C)	100°C
H (180 °C)	125°C

**Input Winding (Primary):** particular attention should be paid if, rather than only one input voltage, additional voltage inputs are required. In this case an increase of the core power is necessary. For example:

Input voltage	Rated power x factor= scaling of the core power	
	1 section	2 sections
230	1	1
230+400	1.23	1.52
230+500	1.26	1.49
400+440	1.06	1.12
400+440+500	1.12	1.25

**Rated Output Voltage:** this is the output voltage of the transformer at rated frequency, rated input voltage, with a rated output current at a rated power factor ( $=1$ ). This is obtained when the transformer is running in continuous service conditions with a rated ambient temperature. If not otherwise agreed, a tolerance of  $\pm 5\%$  is acceptable. For short-circuit proof transformers it is  $\pm 10\%$  for construction.

**No-load Voltage:** this is the secondary voltage of the transformer in no-load conditions, at primary voltage and rated frequency. This formula can be found starting from:

$$\text{voltage drop \%} = \left| \frac{\text{No-load voltage} - \text{rated secondary voltage}}{\text{No-load voltage}} \right| \times 100$$

EN 61558.1 standard gives the following values for isolation and safety of transformers:

Nominal % differences between secondary no-load and loaded voltage:		
up to 10 VA	100	Note: for insulating transformers up to 63VA:20%
from 10VA to 25 VA	50	
over 25 VA to 63 VA	20	For control transformers in accordance with EN 61558.1 part CEI 96-3 standard the max. difference is 10%
over 63 VA to 250 VA	15	
over 250 VA to 630 VA	10	
over 630 VA	5	

**Output Winding:** it means that in case of derivation output, the current is calculated in reference to the highest voltage, if not differently specified. In case of more windings, due to the quantity of isolation, it could be necessary to increase the core power.

**Rated Power:** this is the product of the rated secondary voltage for the rated secondary current. For three-phase transformers it is 3 times the product of the rated secondary voltage for the rated secondary current. For more secondary windings it is the sum of the product of rated secondary voltage for the rated secondary current of the circuits charged simultaneously.

**Autotransformer:** this is a transformer with common input and output windings, without galvanic isolation between the windings. The relative power is given by the formula:

$$P_{app} = P_{nom} \left(1 - \frac{V_1}{V_2}\right)$$

where  $P_{app}$  = power (VA)  
 $P_{nom}$  = rated power (VA)  
 $V_1$  = lower voltage (V)  
 $V_2$  = higher voltage (V)

**Short Circuit Resistance:** here is the classification that the standard EN 61558.1 applies to short circuit proof transformers:

**a) Transformer not inherently short-circuit proof:** this is a transformer in which has been designed to resist extreme temperatures using an external protective device not supplied with the transformer (e.g. external fuses).

**b) Short-circuit proof Transformer:** this is a transformer in which the over-temperature can not exceed the limits specified when the transformer is short circuited, and can function normally after the removal of the short circuit.

• **Transformer short-circuit proof with specific construction:** this is a transformer which comes with a protective device inside which opens the primary or secondary circuit or reduces the current in case of short circuit (e.g. PTC, bi-metal).

• **Transformer short-circuit proof not with specific construction:** this is a transformer which, in the absence of protective devices, in case of short circuit, does not exceed the temperature limits (e.g. small transformer with high internal resistance).

• **Fail-safe transformer:** this is a transformer which after abnormal use, stops working without placing the user at risk (e.g. transformer with thermo-fuse included).

De-rating Tables: the working conditions of rated power ( $P_n$ ) are referred to the following parameters:

- Continuous service
- Frequency: 50Hz...60Hz
- Protection degree: IP00
- Installation up to 1000m a.s.l.
- Ambient temperature:  $t_a=40^\circ\text{C}$

Other conditions are allowed according to the following tables:

#### ALTITUDE:

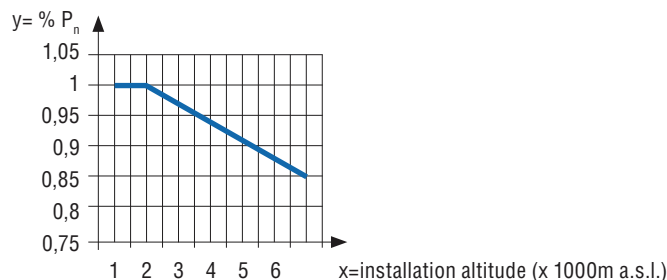

#### AMBIENT TEMPERATURE:

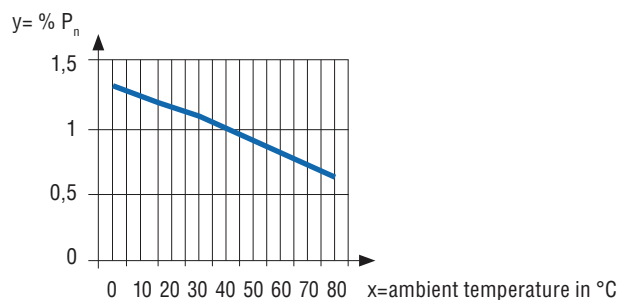

Note: tables are in general. Upon request can be provided tables for the various types of transformers.

**Intermittent Service:** the required power could be calculated for different intermittent services starting from the following parameters:

- rated power (P<sub>n</sub>)
- working time (T<sub>on</sub>)
- resting time (T<sub>off</sub>)

Intermittent rated power P<sub>int</sub>

$$P_{int} = P_n \times \sqrt{\frac{T_{on}}{T_{on} + T_{off}}} \times 1,1$$

For example: rated load = 500VA

T<sub>on</sub> = 10'

T<sub>off</sub> = 20'

$$P_{int} = 500 \times \sqrt{\frac{10}{10+20}} \times 1,1$$

350VA transformer is enough.

**Protection Devices:** as general rule the transformer should be protected against short-circuits on the primary, against over-loads on the secondary. In both cases with delaying fuses (T) or with magneto-thermal switches with delayed tripping curve. Secondary protection calculation (against over-load) has not problems: EN 61558-1 standards provide a tolerance of ±10% on the rated secondary current and in any case on the external label it is indicated the fuse dimension. The primary protection calculation (against the short-circuit) is more difficult. It should be noted that a current peak (I<sub>e</sub>) is generated at insertion moment which is 20-30 times I<sub>n</sub> for about 10ms without protection that will occur in case of short-circuit.

## Protection against short-circuit

P <sub>n</sub>	Input voltage		Output voltage	
	230V	400V	24V	115V
50	0,50	0,315	2	0,40
75	0,80	0,40	3,15	0,63
100	1	0,63	4	1
150	1,50	0,80/1	6,3	1,25
200	2	1,25	8	1,6
250	2,50	1,6	10	2
300	3	1,6	12	2,5
400	3,15	2,5	15	3,15/4
500	4	3	25	4/5
630	5	4	-	5/6,3
800	6	5	-	8
1000	8	6,30	-	8/10

It is necessary to know the short-circuit current, considering also the farthest point of the line transformer-user.

## Known data:

**V<sub>2</sub>**= transformer output voltage

**V<sub>cc</sub>**= short-circuit voltage in % (see catalogue)

**P<sub>n</sub>**= transformer rated power

**L**= line length in meters

**S**= section of the conductor in m<sup>2</sup>

$$I_{2cc} = \frac{V_2}{\frac{V_2^2}{P_n} \times \frac{V_{cc}(\%)}{100} + \frac{0,036 \times l \text{ (m)}}{S \text{ (mm}^2\text{)}}$$

In general it is enough to consider a protection calculated as 1,5-2,5xI<sub>n</sub> prim.

The table below is for single-phase transformers from 50VA to 1000VA with voltages 230-400/24V or 115V

Single-phase transformers - Protections with delaying fuses "T" serie



**METH srl**

Via Fondovilla, 84/F /// 36010 Carrè (VI) - Italy  
Tel. +39.0445.891799 /// Fax +39.0445.891841  
info@meth.it /// International sales: export@meth.it

**[www.meth.it](http://www.meth.it)**



**METH ELECTRIC TRANSFORMERS KFT**

8800 Nagykanizsa, Csengery utca 102 – Hungary  
Tel +36 93900278 /// Fax +36 93900279  
methkft@gmail.com /// International sales: sales@methkft.com

**[www.methkft.com](http://www.methkft.com)**

