





-  Plugs and Sockets
-  Industrial Connectors
-  e-mobility
-  Power Distributors for Outside Areas

CEEtyp Plugs and Sockets 2013



CEEtyp Plugs and Sockets

The indicated standard extracts are for your information but without any liability. In case of doubt please refer to the complete original standard or regulation. The quotes from standards are hints where to get additional information on a specific topic.

We reserve the right for technical changes. Due to technical improvements some products may differ from the pictures as shown in the catalogue.

For prices please refer to our current trade price list.

Update:
www.walther-werke.de

walther
Elektrotechnische Systeme

Walther-Werke · Ferdinand Walther GmbH
Postfach 11 80 · 67298 Eisenberg/Pfalz
Phone: + 49 (0) 63 51 / 4 75-0
Fax: + 49 (0) 63 51 / 4 75-227
www.walther-werke.de
mail@walther-werke.de

International Offices

France

F. Walther Sarl
 100, rue Edouard Branly
 F-59500 Douai
 Tel.: +33 327 081 717
 Fax: +33 327 976 833
contact@walther-fr.com
www.walther-fr.com

Austria

Walther Electric GmbH
 Bayernstraße 39
 A-5071 Wals-Siezenheim
 Tel.: +43 6 62 / 85 47 00-0
 Fax: +43 6 62 / 85 46 32
mail@schurrer.at
www.walther-werke.de

Great Britain

F. Walther Electrics Ltd.
 Unit 4, Cromwell Trading Estate
 Cromwell Road
 GB-Bredbury, Stockport
 Cheshire SK6 2RF
 Tel.: +44 1 61 / 4 94 12 33
 Fax: +44 1 61 / 4 94 50 55
mail@walther.demon.co.uk

USA

F. Walther Electric Corp.
 12 World's Fair Drive Unit F
 USA-Somerset, NJ 08873
 Tel.: +1 7 32-537-9201
 Fax: +1 7 32-537-9209
info@waltherelectric.com
www.waltherelectric.com



Your WALTHER contact persons in Eisenberg















Export Sales Department



Manuela Laux
 Tel.: +49(0)6351/475-217
 Fax: +49(0)6351/475-5217
manuela.laux@walther-werke.de

Karina Rehg
 Tel.: +49(0)6351/475-263
 Fax: +49(0)6351/475-5263
karina.rehg@walther-werke.de

Sigrid Neu-Frank
 Tel.: +49(0)6351/475-212
 Fax: +49(0)6351/475-5212
sigrid.neu-frank@walther-werke.de

Company information		1
Sockets flush/surface mount		2
Plugs		3
Couplers		4
Panel sockets also for cable duct installation		5
Mondo also for cable duct installation		6
Wall sockets switched / fused		7
Light & stage engineering for entertainment industry black enclosure colour		8
7-pole plugs & sockets		9
Socket combinations and stainless steel pillars		10
AutoboxX Consumer boxes		11
Norvo plugs & sockets for extra low voltages > 50 V		12
CEPro plugs & sockets Power + control in one unit		13
Container plugs & sockets		14
Manufacturer declarations		15

Sockets Plugs Couplers



Series A, 3 to 32-pole
Series B, 6 to 48-pole



Wall sockets
switched/
fused

Consumer boxes



Series BB, 10 to 92-pole
Series BA, 6 and 12-pole



Panel sockets
CEPro plugs
and sockets



Series D,
7 to 128-pole

Series DD,
24 to 216-pole
Series MO
Series BHT



Socket
combinations
Plugs and sockets
for extra low voltages



Series MO
Series BHT
Series BV

CEEtyp Plugs and Sockets

The CEEtyp product line ranges from 16 A to 125 A and also comprises Norvo plugs and sockets for extra low voltages up to 50 V with 16 A and 32 A. In addition, matching wall sockets and socket combinations are available. Even plugs and sockets for special applications like container or caravan installation and chemical resistant versions are available.

With its good sense of innovation, WALTHER has often been setting trends with its main product range of CEE plugs and sockets: with its socket combinations as modular system, with the flat CEE flush-mount socket, with the angled plug and the Multi Contact lamellas inside 125 A devices.

PROCON Industrial Connectors

PROCON Industrial connectors are characterized by easy operation thanks to their cleverly designed locking system.

Due to their different housing sizes they are provided with ample wiring space. Other quality features are the ergonomically designed grips and the high-grade powder coating of the housings.

Main application areas are machinery and equipment construction, light and stage engineering, crane control, fairground equipment, switchgear construction and control engineering

Termination methods:

- Screw terminal connection
- Crimp connection
- Insulation displacement connection
- Push-in terminal connection

Charging plugs and sockets
Charging cables



Power distributors for construction sites
Power distributors for camping sites



Charging stations
Wall boxes



Power distributors for allotment gardens
Power distributors for marinas
Coin-operated systems
Consumption billing systems

Testing facilities



Distributors with modular technique
Distributors for fairgrounds and market places
Energy bollards



Pedelec cabinets



Surface / flush-mount distributors
Underfloor distributors

e-mobility

New energy schemes and sustainable mobility strategies will shape the 21st century. Electric vehicles play an important role in this development. They stand for eco-friendly and future-oriented mobility.

To ensure the power supply of electric vehicles, a nationwide charging infrastructure is required. In national and international standardisation committees, Walther actively participates in this development.

In projects with worldwide leading automotive manufacturers and energy suppliers, Walther has established a leading technological position and has specialised on the entire product range between power grid and vehicle.

Power Distributors for Outside Areas

Walther power distributors come from the long established company Bosecker Verteilerbau Sachsen GmbH, which belongs to the Walther group of companies since 2001. With its robust and longlasting products, tailored to customers' requirements, this Walther subsidiary has earned a good reputation.

The products offered under the label "Walther - System Bosecker" include not only power distributors for outside areas but also ready-to-use transformer stations, which are produced in Zittau. Meanwhile, the Walther range of high-quality distributors comprises a multitude of different application-specific types, with numerous special distributors, which are also available with individual equipment variants. A separate series of distributors with AC/DC-sensitive RCDs even covers these customer requirements.

**Over 110 years
of expertise**

Made in Germany

***Walther headquarters,
Eisenberg***



***Subsidiary Bosecker,
Zittau***



Company profile

By establishing his company in Grimma near Leipzig in 1897, Ferdinand Walther laid the foundation for a successful medium-sized company.

In 1945 Walther moved to Bad Reichenhall (Bavaria) and then in 1970 to new larger premises in Eisenberg, near Kaiserslautern (Rhineland-Palatinate)

The good infrastructure of this location - close to the centres Rhine-Main/Rhine-Neckar - enables fast service to all our market partners.

Together, WALTHER in Eisenberg and the subsidiary company BOSECKER in Zittau (Saxonia) have about 300 employees. On 14.500 m² of production, administration and storage space, the headquarters in Eisenberg produces electrotechnical components and systems. On a further 5.000 m² floorspace in Zittau the company produces power distributors for outside areas and transformer compact stations.

The range of systems is continuously enhanced in consultation with the electrical wholesale trade, electrical contractors, industry and planners

A high quality standard is certified by the German Association for the Certification of Quality Management Systems (DQS) with the certificate acc. to DIN EN ISO 9001-2008.



Marketing and Service

Visitors are always welcome.



Fairs and exhibitions

Close contact to the customer, e.g. during German and international electrotechnical fairs, is one of the WALTHER principles.

The results hereof are permanent innovations and improvements.



Profit from the expert advice on site.



Information material

- n CEE catalogue
- n PROCON catalogue
- n e-mobility catalogue
- n short overviews
- n leaflets
- n WALTHER DVD
- n www.walther-werke.de

Technical support

Subsidiaries in Great Britain, France, the United States and Austria, plus agencies in more than 60 countries worldwide offer you quick and competent support.

The WALTHER team will be pleased to assist you in planning and projecting your installation.

Walther - your best connection

- A brand „Made in Germany“
- Over 100 years of best connections to trade, craft and industry
- Consequent loyalty to three-tiered specialist distribution system
- Four product lines - four electrical connections from one source
 - CEEtyp plugs and sockets
 - Procon industrial connectors
 - Power distributors for outside areas
 - e-mobility - charging plugs and sockets, charging cables, charging stations
 - One of the safest and fastest screwless CEE plug and coupler systems for 16 and 32 A.

Design and Production



Tools

Even high precision tools which are required for production are manufactured at WALTHER by means of CNC controlled milling machines and electronically controlled spark eroding and cutting machines.

Experienced designers use the latest CAD technology systems to plan devices for practical use which comply with current standards and regulations. Customer requirements have high priority, like for example:

- n easy assembly
- n ample wiring space
- n first class contacts
- n attractive design



From the smallest connector to the most complex socket combination - WALTHER produces the entire product range in Eisenberg (Rhineland-Palatinate).



All injection moulded plastic items have a high-class and highly compressed surface and are thus stain resistant.

Injection moulding machines

Centrally controlled injection moulding machines produce plastic enclosures from type-tested first grade plastic. An integrated supervision programme corrects deviations, warns or switches the machine off. This ensures consistently high quality.



Die-cast housings

Aluminium housings for Procon industrial connectors are produced on die-cast machines with built-in quality control.

This supervision ensures that only first-class products are accepted for further processing and assembly.



Aluminium bars

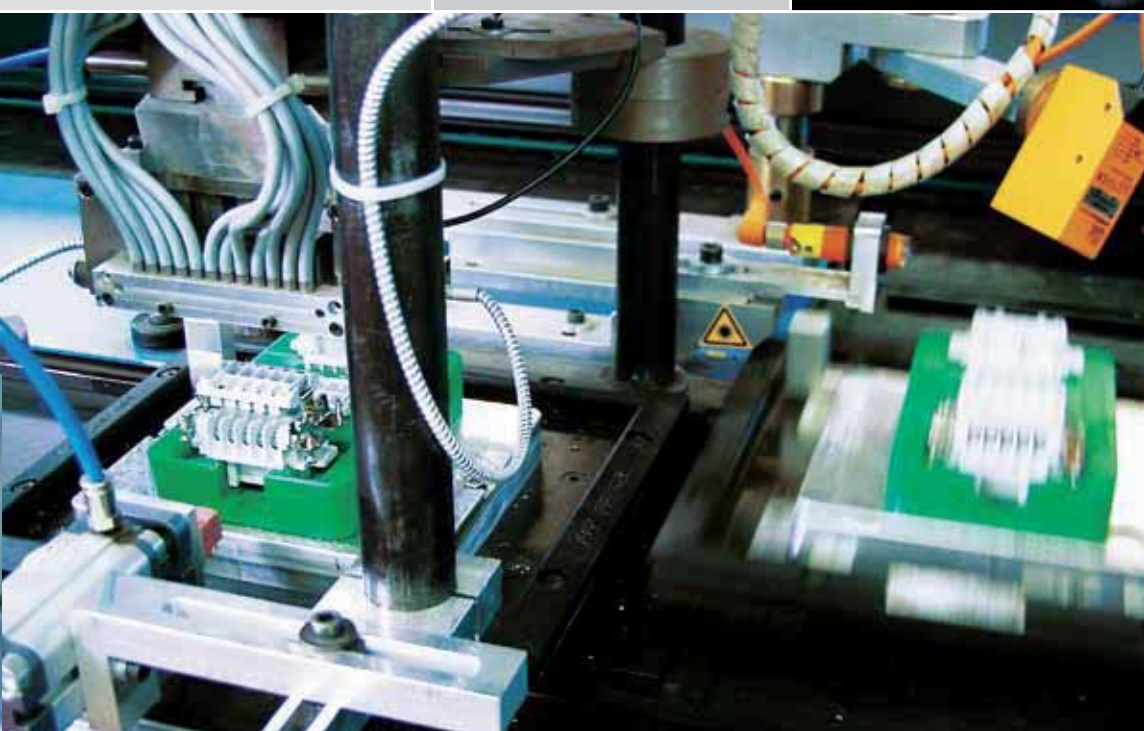

Powder coating facility



Die-cast aluminium housings

Contacts

The heart of a plug and socket device are its contacts. Rotary transfer machines automatically control each contact. Pins and sleeves have to meet highest quality standards. This ensures constantly easy plugging and withdrawing over the years. Furthermore all contacts are equipped with open, captive screws for faster assembly. All contacts are turned from massive brass!



Efficient
Assembly

Proven
Safety



During and after assembly, stringent test are conducted to ensure the quality of WALTHER products.

High volume bulk production items are produced on fully automatic assembly lines.

After each assembly operation the product is electronically tested.

Universal screw-feed drive

All screws have combination heads for use with electrical, pneumatic or manual screw-drivers. Pozidrive, Philips as well as slot blades can be used.



Checked in detail

Each socket combination - including the built-in components like MCBs and RCDs - pass a complete electrical function test.

The impeccable condition of the device is documented on the enclosed test certificate. All data is saved and can be retrieved with the control number.

Worldwide approvals

WALTHER products have gained more than 6.000 approvals worldwide.

These approvals are not only proof of the high product quality but they also certify the electrical safety and compliance with valid standards.

Inspectors of different international testing laboratories check - also without prior notice - the production, the testing equipment and the end products for compliance with the standards.

Technology and Design

Switched wall socket and socket combination



Mondo flush-type wall socket



Angled CEE plug

Mini socket combination

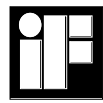

Jürgen R. Göpfert, the well-known industrial designer, gives WALTHER products their attractive, timeless design. Several awards from the Industry Forum Design in Hannover ("Good Industry Design IF") show that functionality and appealing design are absolutely compatible.

Programme family AutoboxX consumer boxes

The new CEE generation from WALTHER has been awarded with an innovation price.

CEE plug/coupler



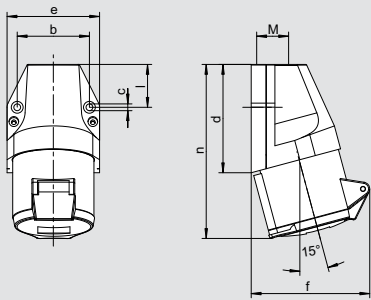

Amp.	16			32		
Poles	3	4	5	3	4	5
b	45,5	60	60	60	60	60
c	5,3	5,3	5,3	5,3	5,3	5,3
d	74	80	80	97	97	97
e	60	74	74	82	82	82
f	75	86	90	103	103	105
l	28	31	31	45	45	45
n	120	128	129	154	154	155
M	20	20	20	25	25	25

Wall sockets, with screw terminals, external fixing, 1 top cable entry, IP 44 ▲

Wall sockets with push-in terminals are the indicated part numbers with SL: SL: 110 SL and 130 SL

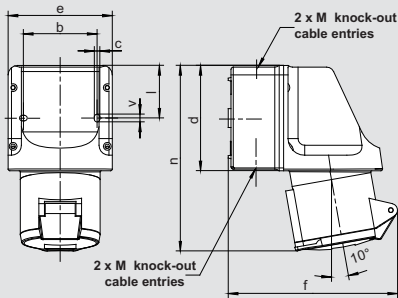

Amp.	16			32		
Poles	3	4	5	3	4	5
b	66,5	66,5	66,5	66,5	66,5	66,5
c	5	5	5	5	5	5
d	96	96	96	96	96	96
e	95	95	95	95	95	95
f	140	143	146	154	154	157
l	47,5	47,5	47,5	47,5	47,5	47,5
n	160	164	164	173	173	173
v	7	7	7	7	7	7
M	20/25	20/25	20/25	20/25	20/25	20/25

Wall sockets, with screw terminals, internal fixing, 2 knockout cable entries on top and bottom, 1 knockout entry in the back wall, IP 44 ▲

Wall sockets with push-in terminals are the indicated part numbers with SL: 111 SL and 131 SL

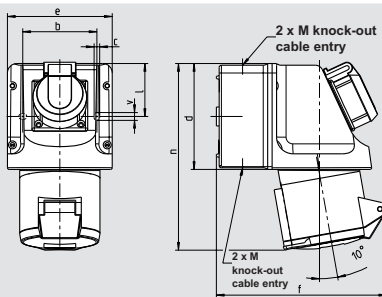

Amp.	16		32	
Poles	3	5	3	5
b	66,5	66,5	66,5	66,5
c	5	5	5	5
d	96	96	96	96
e	95	95	95	95
f	140	146	154	157
l	47,5	47,5	47,5	47,5
n	160	164	173	173
v	7	7	7	7
M	20/25	20/25	20/25	20/25

Mini combinations, CEEtyp wall socket with Schuko socket, 16 A, 230 V, 2 P + E, IP 44 ▲
2 cable entries on top and bottom, 1 knockout entry in the back wall

- 1) unwired
- 2) Schuko socket protected with fuse 6,3 A „G“, 5 x 20 mm
- 3) 16 A and 32 A supply lines required

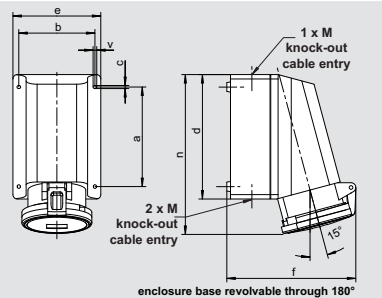

Amp.	63		
Poles	3	4	5
a	136	136	136
b	104	104	104
c	4,2	4,2	4,2
d	172	172	172
e	121	121	121
f	178	178	178
n	220	220	220
v	5	5	5

Wall sockets, internal fixing, 1 top cable entry, open, 2 bottom cable entries, knock-out, bottom part revolvable through 180 °, IP 44 ▲

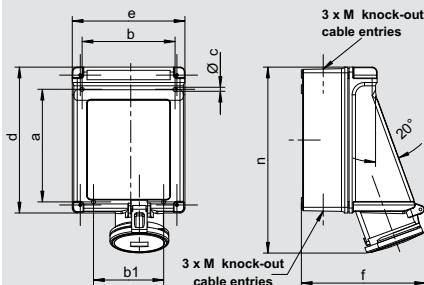

Amp.	63		
Poles	3	4	5
a	183	183	183
b	151	151	151
b1	114	114	114
c	6,5	6,5	6,5
d	237	237	237
e	183	183	183
f	196	196	196
n	302	302	302
M	25/32/40	25/32/40	25/32/40

Wall sockets, internal fixing, 2 top cable entries, 2 bottom cable entries, knock-out, IP 44 ▲



Ampère	Poles	110 V 50 a. 60 Hz			230 V 50 a. 60 Hz			400 V 50 a. 60 Hz			500 V 50 a. 60 Hz			> 50 - 500 V 100 - 300 Hz			> 50 - 500 V over 300 - 500 Hz			
		3pole 4h	4pole 4h	5pole 4h	3pole 6h	4pole 9h	5pole 9h	3pole 9h	4pole 6h	5pole 6h	3pole 7h	4pole 7h	5pole 7h	3pole 10h	4pole 10h	5pole 10h	3pole 2h	4pole 2h	5pole 2h	
Part numbers																				
16	3	110 304			110 306			110 309												10/60
16	4	110 404			110 409			110 406			110 407		110 410		110 402					10
16	5	110 504			110 509			110												10/60
16	5							110 Ni												10
16	5							110 SL												10/60
32	3	130 304			130 306			130 309												10
32	4	130 404			130 409			130 406			130 407		130 410		130 402					10
32	5	130 504			130 509			130												10/60
32	5							130 Ni												10/60
32	5							130 SL												10/60
16	3	111 304			111 306			111 309												5
16	4	111 404			111 409			111 406			111 407		111 410		111 402					5
16	5	111 504			111 509			111												5
16	5							111 Ni												5
16	5							111 SL												5
32	3	131 304			131 306			131 309												5
32	4	131 404			131 409			131 406			131 407		131 410		131 402					5
32	5	131 504			131 509			131												5
32	5							131 Ni												5
32	5							131 SL												5
16	3				114 306															5
16	3				115 306 ²⁾															5
32	3				134 306 ³⁾															5
32	3				135 306 ²⁾															5
16	5							114												5
16	5							114 UV ¹⁾												5
16	5							115 ²⁾												5
16	5							115 Ni												5
32	5							134 ³⁾												5
32	5							134 UV ^{1, 3)}												5
32	5							135 Ni												5
32	5							135 ²⁾												5
63	3	161 304			161 306			161 309												2
63	4	161 404			161 409			161 406			161 407		161 410		161 402					2
63	5	161 504			161 509			161												2
63	3	163 304			163 306			163 309												1
63	4	163 404			163 409			163 406			163 407		163 410		163 402					1
63	5	163 504			163 509			163												1
<p>The here listed 63A + 125A wall sockets are also available with pilot contact. To order them, simply add a "P" behind the standard part number.</p>																				



110



131



114



161



163

Availability of blue printed (or not listed) frequencies and voltages up to 690 V on request!

1) unwired
2) Schuko socket protected with fuse 6,3 A „G“, 5 x 20 mm
3) 16 A and 32 A supply lines required

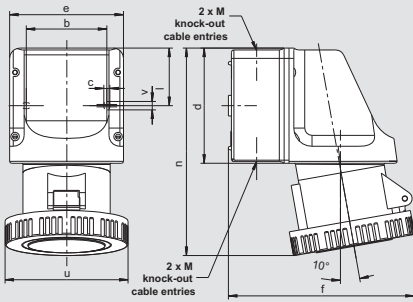

Amp.	16			32		
Poles	3	4	5	3	4	5
b	66,5	66,5	66,5	66,5	66,5	66,5
c	5	5	5	5	5	5
d	96	96	96	96	96	96
e	95	95	95	95	95	95
f	140	144	147	156	156	156
l	47,5	47,5	47,5	47,5	47,5	47,5
n	164	164	164	176	176	176
u	72	81	88	96	96	103
v	7	7	7	7	7	7
M	20/25	20/25	20/25	20/25	20/25	20/25

Wall sockets,

internal fixing,
2 top and bottom cable entries, knock-out,
1 knockout entry in the back wall,
IP 67

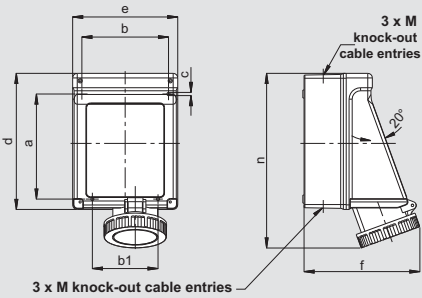

Amp.	63		
Poles	3	4	5
a	183	183	183
b	151	151	151
b1	114	114	114
c	6,5	6,5	6,5
d	237	237	237
e	183	183	183
f	209	209	209
n	309	309	309
M	25/32/40	25/32/40	25/32/40

Wall sockets,

internal fixing,
3 top cable entries, knockout,
3 bottom cable entries, knockout,
IP 67

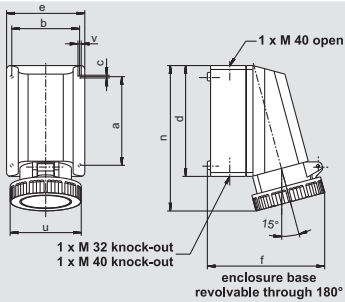

Amp.	63		
Poles	3	4	5
a	136	136	136
b	104	104	104
c	4,2	4,2	4,2
d	172	172	172
e	121	121	121
f	178	178	178
n	224	224	224
v	5	5	5

Wall sockets,

internal fixing,
1 top cable entry, open,
2 bottom cable entries, knockout,
bottom part revolvable through 180 °,
IP 67

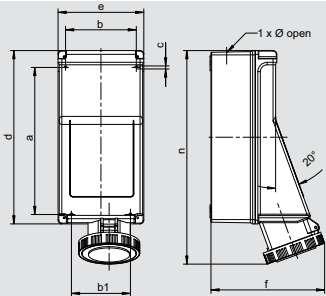

Amp.	125		
Poles	3	4	5
a	316	316	316
b	151	151	151
b1	126	126	126
c	6,5	6,5	6,5
d	370	370	370
e	183	183	183
f	243	243	243
n	450	450	450
M	50	50	50

Wall sockets

Multi-Contact =

high contact pressure - easy withdrawal,
internal fixing,
top cable entry:
1 x M 50,
terminal block set 3, 4 and 5 x 50 mm²,
IP 67

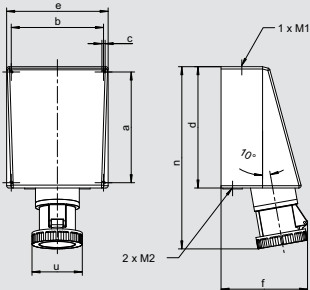

Amp.	125		
Poles	3	4	5
a	240	240	240
b	200	200	200
c	7	7	7
d	263	263	263
e	220	220	220
f	190	190	190
n	406	406	406
u	130	130	130
M 1	20/50	20/50	20/50
M 2	40	40	40

Wall sockets

Multi-Contact =

high contact pressure - easy withdrawal,
internal fixing,
top cable entry: 1 x M 50 and 1 x M 20,
bottom cable entry: 2 x M 40,
with terminal block set 3, 4 and 5 x 50 mm²,
OK = without terminal block set,
IP 67



Multi-Contact

Since more than 30 years all 125 A devices come with multi contacts.

They provide for **easy plugging and withdrawing** and **constant contact pressure** over the years.

The multi contact ring, consisting of 13 lamellas, transmits 28 A per lamella, i.e. the transition from pin to sleeve is designed for 364 A - **high security**. The lamellas are spring-mounted and thus **self-cleaning**.



Ampère	Poles	110 V 50 a. 60 Hz			230 V 50 a. 60 Hz			400 V 50 a. 60 Hz			500 V 50 a. 60 Hz			> 50 - 500 V 100 - 300 Hz			> 50 - 500 V over 300 - 500 Hz			
		3pole 4h	4pole 4h	5pole 4h	3pole 6h	4pole 9h	5pole 9h	3pole 9h	4pole 6h	5pole 6h	3pole 7h	4pole 7h	5pole 7h	3pole 10h	4pole 10h	5pole 10h	3pole 2h	4pole 2h	5pole 2h	

Part numbers

16	3	119 304	119 306	119 309															5
16	4	119 404	119 409	119 406	119 407	119 410	119 402												5
16	5	119 504	119 509	119															5
32	3	139 304	139 306	139 309															5
32	4	139 404	139 409	139 406	139 407	139 410	139 402												5
32	5	139 504	139 509	139															5
63	3	168 304	168 306	168 309															1
63	4	168 404	168 409	168 406	168 407	168 410	168 402												1
63	5	168 504	168 509	168															1
63	3	169 304	169 306	169 309															2
63	4	169 404	169 409	169 406	169 407	169 410	169 402												2
63	5	169 504	169 509	169															2
125	3	178 304	178 306	178 309															1
125	4	178 404	178 409	178 406	178 407	178 410	178 402												1
125	5	178 504	178 509	178															1
125	3	178 304 OK	178 306 OK	178 309 OK															1
125	3	179 304	179 306	179 309															1
125	4	179 404	179 409	179 406	179 407	179 410	179 402												1
125	5	179 504	179 509	179															1
125	3	179 304 OK	179 306 OK	179 309 OK															1
125	4	179 404 OK	179 409 OK	179 406 OK	179 407 OK	179 410 OK	179 402 OK												1
125	5	179 504 OK	179 509 OK	179 OK															1



139



168



169



178



179



The wall socket 125 A, type 179, is provided with a **terminal block set for quick connection**. If you would like to order the wall socket without terminal block set then please add the suffix 'OK' to the part number.

The here listed 63 A + 125 A wall sockets are also available with **pilot contact**. To order them, simply add a "P" behind the standard part number.

Plugs
- screwless
- with screw terminals

3

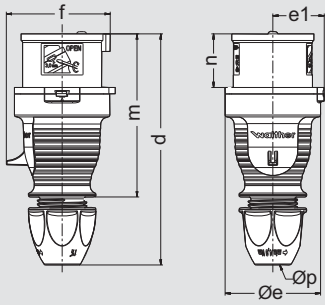

Amp.	16	16	32	32	32
Poles	4	5	3	4	5
d	150-161	150-161	173-185	173-185	174-183
Øe	65	65	72	72	72
e1	35	35	38,5	38,5	38,5
f	63	71	75	75	83
m	111	111	128	128	128
n	37	37	45,5	45,5	45,5
Øp	7,5 - 18,5	7,5 - 18,5	10 - 22,5	10 - 22,5	10 - 22,5

Screwless plugs, with insulation displacement connection,
with exterior cable gland,
IP 44 ▲

Conductor cross sections:

16 A: 1 - 2,5 mm² / 32 A: 2,5 - 6 mm²

Cable diameters:

16 A: 7,5 - 18,5 mm / 32 A: 10 - 22,5 mm

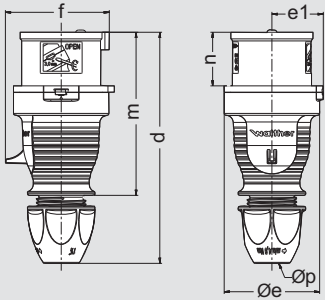

Amp.	16	16	32	32	32
Poles	4	5	3	4	5
d	150-161	150-161	173-185	173-185	174-183
Øe	65	65	72	72	72
e1	35	35	38,5	38,5	38,5
f	63	71	75	75	83
m	111	111	128	128	128
n	37	37	45,5	45,5	45,5
Øp	7,5 - 18,5	7,5 - 18,5	10 - 22,5	10 - 22,5	10 - 22,5

Plugs, screw terminal connection,
with exterior cable gland,
IP 44 ▲

Conductor cross sections:

16 A: 1 - 2,5 mm² / 32 A: 2,5 - 6 mm²

Cable diameters:

16 A: 7,5 - 18,5 mm / 32 A: 10 - 22,5 mm

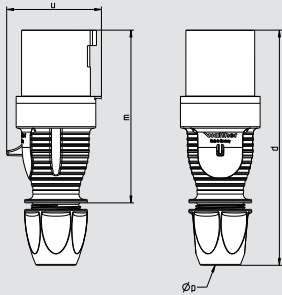

Amp.	63		
Poles	3	4	5
d	246	246	246
u	95	95	95
m	174	174	174
Øp	14-33	14-33	14-33

Plugs, screw terminal connection,
with exterior cable gland,
IP 44 ▲

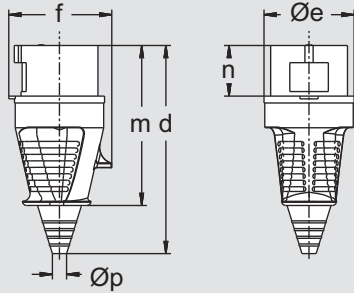

Amp.	16	63		
Poles	3	3	4	5
d	143	252	252	252
Øe	51	81	81	81
f	60	97	97	97
m	108	192	192	192
n	37	67	67	67
Øp	7/13	15/33	15/33	15/33

Plugs, screw terminal connection,
with flexible cable entry,
IP 44 ▲

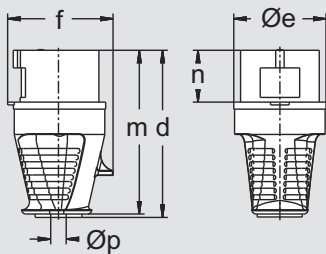

Amp.	16
Poles	3
d	111
Øe	51
f	60
m	108
n	37
Øp	8/15

Plugs, screw terminal connection,
with inverted cable entry,
IP 44 ▲

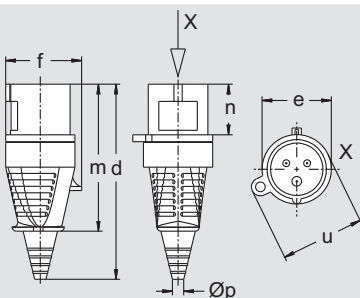

Amp.	16
Poles	3
d	143
e	51
f	60
m	108
n	37
Øp	7/13
u	61

Plugs, screw terminal connection,
with flexible cable entry,
with eye for padlock, for locking with panel
socket 512 306, 512 304 and 512 309,
IP 44 ▲

Ampère	Poles	110 V 50 a. 60 Hz			230 V 50 a. 60 Hz			400 V 50 a. 60 Hz			500 V 50 a. 60 Hz			> 50 - 500 V 100 - 300 Hz			> 50 - 500 V over 300 - 500 Hz			
		3pole 4h	4pole 4h	5pole 4h	3pole 6h	4pole 9h	5pole 9h	3pole 9h	4pole 6h	5pole 6h	3pole 7h	4pole 7h	5pole 7h	3pole 10h	4pole 10h	5pole 10h	3pole 2h	4pole 2h	5pole 2h	



Part numbers

Ampère	Poles	110 V	230 V	400 V	500 V	> 50 - 500 V	> 50 - 500 V	
16	4	210 404 SL	210 409 SL	210 406 SL	210 407 SL	210 410 SL	210 402 SL	10/60
16	5	210 504 SL	210 509 SL	210 SL				10/60
32	3	230 304 SL	230 306 SL	230 309 SL				10/60
32	4	230 404 SL	230 409 SL	230 406 SL	230 407 SL	230 410 SL	230 402 SL	10/60
32	5	230 504 SL	230 509 SL	230 SL				10/60
16	4	210 404	210 409	210 406	210 407	210 410	210 402	10
16	5	210 504	210 509	210				10/60
32	3	230 304	230 306	230 309				10
32	4	230 404	230 409	230 406	230 407	230 410	230 402	10
32	5	230 504	230 509	230				10/60
63	3	262 304	262 306	262 309				5
63	4	262 404	262 409	262 406	262 407	262 410	262 402	5
63	5	262 504	262 509	262				5
63	5			262 Ni				5
16	3	210 304	210 306	210 309				10
16	5			210 Ni				10
32	5			230 Ni				10
63	3	260 304	260 306	260 309				5
63	4	260 404	260 409	260 406	260 407	260 410	260 402	5
63	5	260 504	260 509	260				5
63	5			260 Ni				5
16	3	215 304	215 306	215 309				10
16	3	212 304	212 306	212 309				10



3

Availability of blue printed (or not listed) frequencies and voltages up to 690 V on request!

Plugs
- screwless
- with screw terminals

3

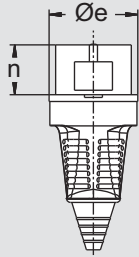
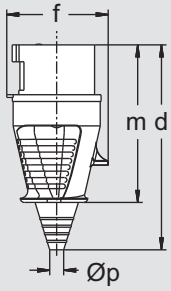

Amp.	16	32
Poles	5	5
d	153	181
Øe	65	72
f	75	88
m	117	138
n	37	46
Øp	8/21	11/24

Phase inverters,
screw terminal connection,
with flexible cable entry,
IP 44 ▲

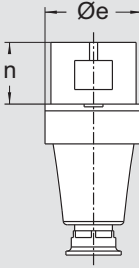
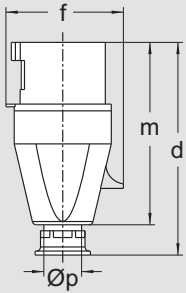

Amp.	16	32
Poles	5	5
d	131	155
Øe	65	73
f	75	88
m	112	133
n	37	46
Øp	7,5 - 14,5	10 - 19,5

Phase inverters,
screw terminal connection,
with trumpet gland,
IP 44 ▲

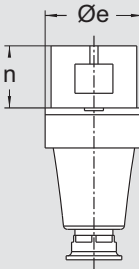
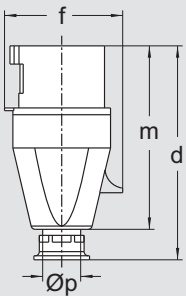

Amp.	16			32			63		
Poles	3	4	5	3	4	5	3	4	5
d	123	131	131	155	155	155	240	240	240
Øe	51	65	65	73	73	73	81	81	81
f	60	68	75	79	79	88	97	97	97
m	118	112	112	133	133	133	192	192	192
n	37	37	37	46	46	46	67	67	67
Øp	7,5-14,5	7,5-14,5	7,5-14,5	10-19,5	10-19,5	10-19,5	18-34,5	18-34,5	18-34,5

Plugs, screw terminal connection,
with trumpet gland,
IP 44 ▲

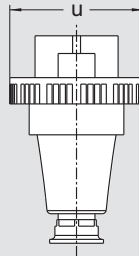
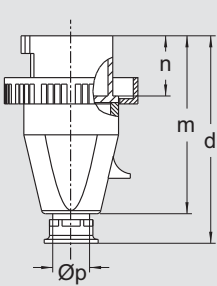

Amp.	16
Poles	3
d	126
m	110
n	37
u	72
Øp	7,5-14,5

Plugs, screw terminal connection,
with trumpet gland, IP 67 ♠♠

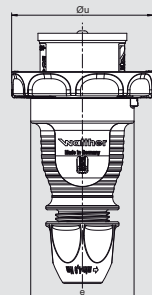
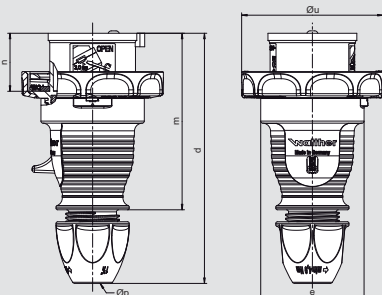

Amp.	16	16	32	32
Poles	4	5	3 / 4	5
d	150-161	150-161	174-183	174-183
Øe	Ø 65	Ø 65	Ø 72	Ø 72
m	111	111	127	127
n	36,5	36,5	45,5	45,5
Øu	Ø 81	Ø 89	Ø 95	Ø 100
Øp	7,5-18,5	7,5-18,5	10-22,5	10-22,5

Plugs, screw terminal connection,
with cable gland, IP 67 ♠♠

or

Plugs, screwless (SL) with
insulation displacement connection,
with cable gland, IP 67 ♠♠

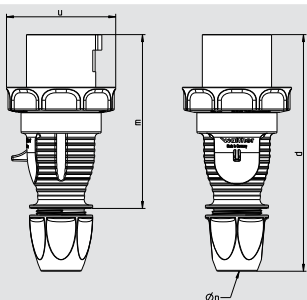

Amp.	63		
Poles	3	4	5
d	246	246	246
u	109	109	109
m	174	174	174
Øp	14-33	14-33	14-33

Plugs, screw terminal connection,
with cable gland, IP 67 ♠♠

Plugs
- screwless
- with screw terminals

3

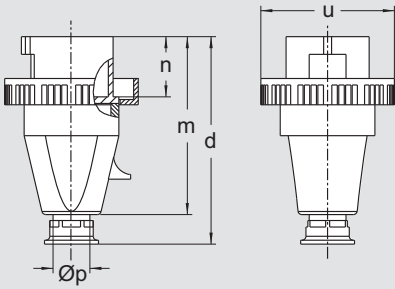

Amp.	63			125		
Poles	3	4	5	3	4	5
d	243	243	243	315	315	315
m	195	195	195	258	258	258
n	67	67	67	75,5	75,5	75,5
u	110	110	110	130	130	130
Øp	18-35	18-35	18-35	24-45	24-45	24-45

Plugs, screw terminal connection,
with trumpet gland,
IP 67

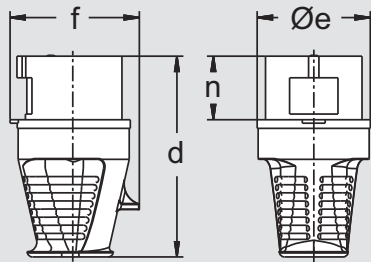

Amp.	16		32		63	
Poles	4	5	4	5	4	5
d	65	65	155	72	240	81
Øe	58	65	72	72	81	81
f	68	75	79	88	97	97
n	37	37	46	46	67	67

Phase sequence control plugs,
IP 44

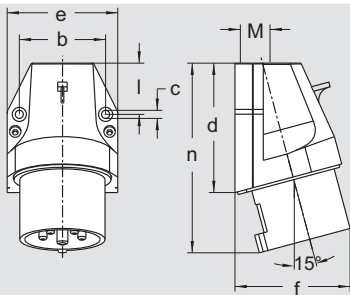

Amp.	16			32		
Poles	3	4	5	3	4	5
b	45,5	60	60	60	60	60
c	5,3	5,3	5,3	5,3	5,3	5,3
d	74	80	80	97	97	97
e	60	74	74	82	82	82
f	60	73	73	80	80	86
l	28	31	31	45	45	45
n	110	117	117	141	141	141
M	20	20	20	25	25	25

Wall mount appliance inlets,
external fixing,
1 top cable entry,
IP 44

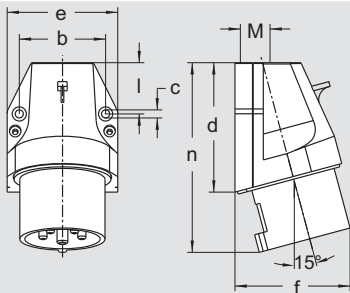

Amp.	16			32		
Poles	3	4	5	3	4	5
b	45,5	60	60	60	60	60
c	5,3	5,3	5,3	5,3	5,3	5,3
d	74	80	80	97	97	97
e	60	74	74	82	82	82
f	60	73	73	80	80	86
l	28	31	31	45	45	45
n	110	117	117	141	141	141
M	20	20	20	25	25	25

Wall mount appliance inlets,
external fixing,
1 top cable entry,
IP 44

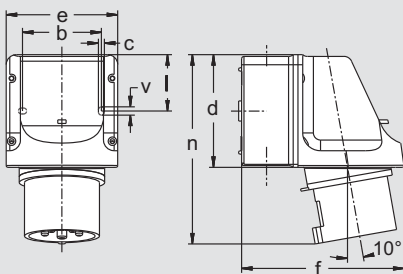

Amp.	16		32		
Poles	4	5	3	4	5
b	66,5	66,5	66,5	66,5	66,5
c	5	5	5	5	5
d	96	96	96	96	96
e	95	95	95	95	95
f	140	140	140	140	140
l	47,5	47,5	47,5	47,5	47,5
n	151	151	160	160	160
v	7	7	7	7	7
M	20/25	20/25	20/25	20/25	20/25

Wall mount appliance inlets,
internal fixing,
2 knock-out cable entries on top and bottom,
1 knock-out entry in the back wall,
IP 44

Ampère	Poles	110 V 50 a. 60 Hz			230 V 50 a. 60 Hz			400 V 50 a. 60 Hz			500 V 50 a. 60 Hz			> 50 - 500 V 100 - 300 Hz			> 50 - 500 V over 300 - 500 Hz			
		3pole 4h	4pole 4h	5pole 4h	3pole 6h	4pole 9h	5pole 9h	3pole 9h	4pole 6h	5pole 6h	3pole 7h	4pole 7h	5pole 7h	3pole 10h	4pole 10h	5pole 10h	3pole 2h	4pole 2h	5pole 2h	



Part numbers									
63	3	269 304	269 306	269 309					5
63	4	269 404	269 409	269 406	269 407	269 410	269 402	5	
63	5	269 504	269 509	269				5	
63	5			269 Ni				5	
125	3	279 304	279 306	279 309				2	
125	4	279 404	279 409	279 406	279 407	279 410	279 402	2	
125	4	279 404	279 409	279 406	279 407	279 410	279 402	2	
125	5			279 Ni				2	
for voltage ranges of 110 V - 690 V									
16	4			210 406 DF				10	
16	5			210 DF				10	
32	4			230 406 DF				10	
32	5			230 DF				10	
63	4			260 406 DF				10	
63	5			260 DF				5	
16	3	610 304	610 306	610 309				10	
16	4	610 404	610 409	610 406	610 407	610 410	610 402	10	
16	5	610 504	610 509	610				10/60	
16	3			610 Ni				10	
32	3	630 304	630 306	630 309				10	
32	4	630 404	630 409	630 406	630 407	630 410	630 402	10	
32	5	630 504	630 509	630				10	
32	5	630 504	630 509	630 Ni				10	
16	5			610 PH				10	
16	5			610 PH Ni				10	
16	5			611 PH Ni				10	
32	5			630 PH				10	
32	5			630 PH Ni				10	
32	5			631 PH Ni				10	
16	4	616 404	616 409	616 406	616 407	616 410	616 402	5	
16	5	616 504	616 509	616				5	
32	3	636 304	636 306	636 309				5	
32	4	636 404	636 409	636 406	636 407	636 410	636 402	5	
32	5	636 504	636 509	636				5	



269



230DF



610



610 Ni



636

3

Plugs
- screwless
- with screw terminals

3

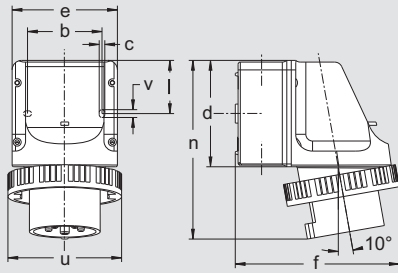

Amp.	16			32		
Poles	3	4	5	3	4	5
b	66,5	66,5	66,5	66,5	66,5	66,5
c	5	5	5	5	5	5
d	96	96	96	96	96	96
e	95	95	95	95	95	95
f	140	140	140	147	147	150
l	47,5	47,5	47,5	47,5	47,5	47,5
n	154	154	154	164	164	164
u	72	81	88	96	96	103
v	7	7	7	7	7	7
M	20/25	20/25	20/25	20/25	20/25	20/25

Wall mount appliance inlets,
internal fixing,
2 knock-out cable entries on top and bottom
1 knock-out entry in the back wall
IP 67

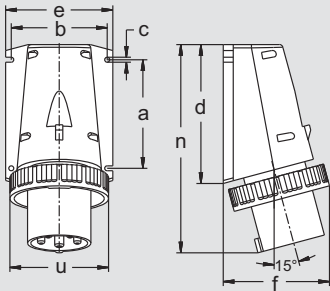

Amp.	63		
Poles	3	4	5
a	136	120	120
b	104	106	106
c	6	5,6	5,6
d	170	152	152
e	118	118	118
f	171	118	118
n	250	232	232
u	113	113	113
M	40	40	40

Wall mount appliance inlets,
external fixing,
1 top cable entry,
contacts not nickel-plated,
IP 67

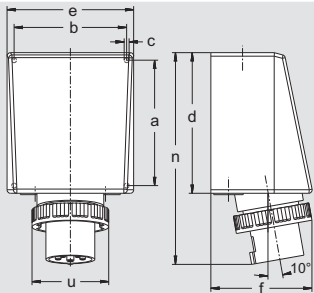

Amp.	125		
Poles	3	4	5
a	240	240	240
b	200	200	200
c	7	7	7
d	263	263	263
e	220	220	220
f	175	175	175
n	390	390	390
u	130	130	130
M1	50/20	50/20	50/20
M2	40	40	40

Wall mount appliance inlets,
internal fixing,
1 top cable entry M 50 and 1 x M 20,
2 bottom cable entries M 40,
3-pole: with terminal block set 3 x 50 mm²,
4-pole: with terminal block set 4 x 50 mm²,
5-pole: with terminal block set 5 x 50 mm²,
IP 67

OK = without terminal block set

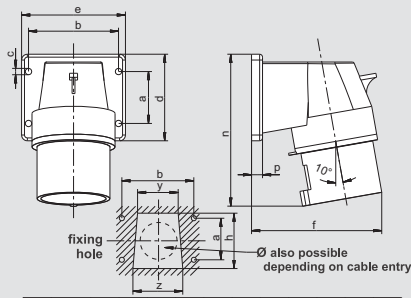

Amp.	16			32			63		
Poles	3	4	5	3	4	5	3	4	5
a	30	40	40	45	45	45	90	90	90
b	55	68	68	78	78	78	90	90	90
c	5,5	5,5	5,5	5,5	5,5	5,5	6,2	6,2	6,2
d	52	66	66	75	75	75	114	114	114
e	65	80	80	90	90	90	114	114	114
f	72	90	92	103	103	103	116	116	116
h	38	52	52	60	60	60	70	70	70
n	97	110	110	129	129	129	185	185	185
p	9,5	9,5	9,5	9,5	9,5	9,5	6	6	6
y	30	38	38	44	44	44	56	56	56
z	36	46	46	54	54	54	65	65	65

Panel mount appliance inlets,
angled, with screwed flange enclosure,
IP 44

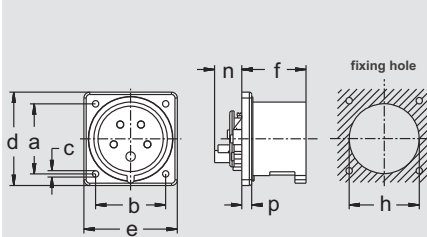

Amp.	16			32			Art. 600 ... :
Poles	3	4	5	3	4	5	Amp. 16
a	47	60	60	60	60	60	Poles 3
b	47	60	60	60	60	60	a 60
c	5,5	5,5	5,5	5,5	5,5	5,5	b 60
d	62	80	80	80	80	80	c 5,5
e	62	80	80	80	80	80	d 75
f	47	47	47	56	56	56	e 75
h	50	67	67	71	71	71	f 47
n	22	22	22	22	22	22	h 50
p	8,5	8,5	8,5	8,5	8,5	8,5	n 22
							p 8,5

Panel mount appliance inlets,
straight, screwed flange,
IP 44

- a retaining means
has to be fitted on the device -

*) the 3 x 16 A version is alternatively
available with 75 x 75 mm flange

Ampère	Poles	110 V 50 a. 60 Hz			230 V 50 a. 60 Hz			400 V 50 a. 60 Hz			500 V 50 a. 60 Hz			> 50 - 500 V 100 - 300 Hz			> 50 - 500 V over 300 - 500 Hz			
		3pole 4h	4pole 4h	5pole 4h	3pole 6h	4pole 9h	5pole 9h	3pole 9h	4pole 6h	5pole 6h	3pole 7h	4pole 7h	5pole 7h	3pole 10h	4pole 10h	5pole 10h	3pole 2h	4pole 2h	5pole 2h	



Part numbers

Ampère	Poles	110 V 50 a. 60 Hz	230 V 50 a. 60 Hz	400 V 50 a. 60 Hz	500 V 50 a. 60 Hz	> 50 - 500 V 100 - 300 Hz	> 50 - 500 V over 300 - 500 Hz	
16	3	618 304	618 306	618 309	upper part without retaining means			5
16	4	618 404	618 409	618 406	618 407	618 410	618 402	5
16	5	618 504	618 509	618				5
32	3	638 304	638 306	638 309				5
32	4	638 404	638 409	638 406	638 407	638 410	638 402	5
32	5	638 504	638 509	638				5
63	3	668 304	668 306	668 309				2
63	4	668 404	668 409	668 406	668 407	668 410	668 402	2
63	5	668 504	668 509	668				2
125	3	678 304	678 306	678 309				1
125	4	678 404	678 409	678 406	678 407	678 410	678 402	1
125	5	678 504	678 509	678				1
125	3	678 304 OK	678 306 OK	678 309 OK				1
125	4	678 404 OK	678 409 OK	678 406 OK	678 407 OK	678 410 OK	678 402 OK	1
125	5	678 504 OK	678 509 OK	678 OK				1
16	3	611 304	611 306	611 309				10
16	4	611 404	611 409	611 406	611 407	611 410	611 402	10
16	5	611 504	611 509	611				10
32	3	631 304	631 306	631 309				10
32	4	631 404	631 409	631 406	631 407	631 410	631 402	10
32	5	631 504	631 509	631				10
63	3	661 304	661 306	661 309				5
63	4	661 404	661 409	661 406	661 407	661 410	661 402	5
63	5	661 504	661 509	661				5
16	3	600 304 *	600 306 *	600 309 *				10
16	3	615 304	615 306	615 309				10
16	4	615 404	615 409	615 406	615 407	615 410	615 402	10
16	5	615 504	615 509	615				10
32	3	635 304	635 306	635 309				10
32	4	635 404	635 409	635 406	635 407	635 410	635 402	10
32	5	635 504	635 509	635				10



3

Availability of blue printed (or not listed) frequencies and voltages up to 690 V on request!

Plugs
- screwless
- with screw terminals

3

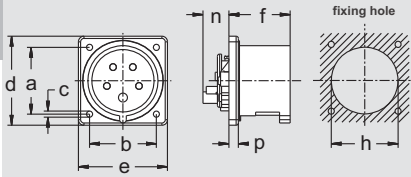

Amp.	16	32
Poles	5	5
a	60	60
b	60	60
c	5,5	5,5
d	80	80
e	80	80
f	47	56
h	67	71
n	22	22
p	8,5	8,5

Panel mount appliance inlets
as phase inverters

straight, screwed flange,
IP 44 ▲

- a retaining means
has to be fitted on the device -

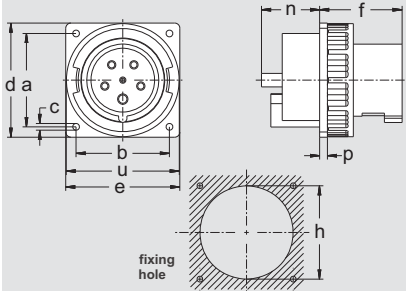

Amp.	125		
Poles	3	4	5
a	104	104	104
b	104	104	104
c	6,5	6,5	6,5
d	130	130	130
e	130	130	130
f	93	93	93
h	90	90	90
n	56	56	56
p	7,5	7,5	7,5
u	130	130	130

Panel mount appliance inlets,
straight, screwed flange,
IP 67 ▲▲

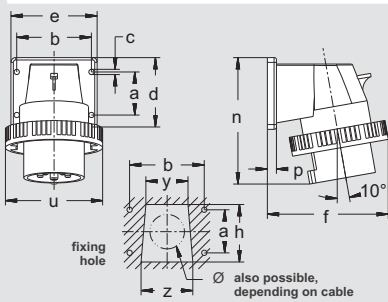

Amp.	16			32			63		
Poles	3	4	5	3	4	5	3	4	5
a	30	40	40	45	45	45	90	90	90
b	55	68	68	78	78	78	90	90	90
c	5,5	5,5	5,5	5,5	5,5	5,5	6,2	6,2	6,2
d	52	66	66	75	75	75	114	114	114
e	65	80	80	90	90	90	114	114	114
f	81	99	103	111	111	117	129	129	129
h	38	52	52	60	60	60	90	90	90
n	98	111	113	131	131	131	184	184	184
p	9,5	9,5	9,5	9,5	9,5	9,5	6	6	6
u	72	81	88	96	96	103	110	110	110
y	30	38	38	44	44	44	56	56	56
z	36	46	46	54	54	54	65	65	65

Panel mount appliance inlets,
angled, screwed flange enclosure,
IP 67 ▲▲

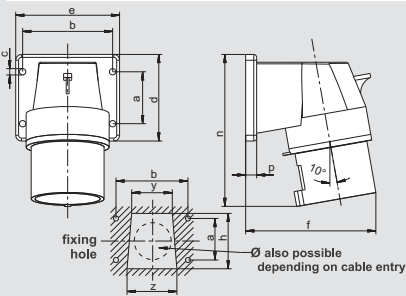

Amp.	16	32
Poles	5	5
a	40	45
b	68	78
c	5,5	5,5
d	66	75
e	80	90
f	92	103
h	52	60
n	110	129
p	9,5	9,5
y	38	44
z	46	54

Panel mount appliance inlets
as phase inverters,
angled, screwed flange enclosure,
IP 44 ▲

Ampère	Poles	110 V 50 a. 60 Hz			230 V 50 a. 60 Hz			400 V 50 a. 60 Hz			500 V 50 a. 60 Hz			> 50 - 500 V 100 - 300 Hz			> 50 - 500 V over 300 - 500 Hz			
		3pole 4h	4pole 4h	5pole 4h	3pole 6h	4pole 9h	5pole 9h	3pole 9h	4pole 6h	5pole 6h	3pole 7h	4pole 7h	5pole 7h	3pole 10h	4pole 10h	5pole 10h	3pole 2h	4pole 2h	5pole 2h	



Part numbers

Ampère	Poles	110 V 50 a. 60 Hz	230 V 50 a. 60 Hz	400 V 50 a. 60 Hz	500 V 50 a. 60 Hz	> 50 - 500 V 100 - 300 Hz	> 50 - 500 V over 300 - 500 Hz	
16 32	5			615 PH 635 PH				10 10
125	3	679 304	679 306	679 309				2
125	4	679 404	679 409	679 406	679 407	679 410	679 402	2
125	5	679 504	679 509	679				2
125	5			679 Ni				2
16	3	619 304	619 306	619 309				10
16	4	619 404	619 409	619 406	619 407	619 410	619 402	10
16	5	619 504	619 509	619				10
16	5			619 Ni				10
32	3	639 304	639 306	639 309				5
32	4	639 404	639 409	639 406	639 407	639 410	639 402	5
32	5	639 504	639 509	639				5
32	5			639 Ni				5
63	3	669 304	669 306	669 309				5
63	4	669 404	669 409	669 406	669 407	669 410	669 402	5
63	5	669 504	669 509	669				5
63	5			669 Ni				5
16	5			611 PH				10
32	5			631 PH				10



3

Availability of blue printed (or not listed) frequencies and voltages up to 690 V on request!

Couplers
- screwless
- with screw terminals

4

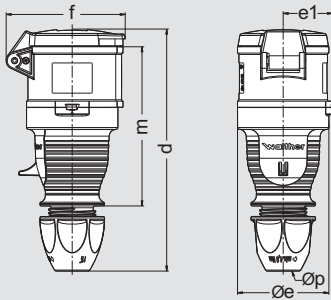

Amp.	16	16	32	32	32
Poles	4	5	3	4	5
d	165-176	165-176	189-199	189-199	189-199
Øe	65	65	72	72	72
e1	35	35	38,5	38,5	38,5
f	77	85	91	91	97
m	114	114	130	130	130
Øp	7,5 - 18,5	7,5 - 18,5	10 - 22,5	10 - 22,5	10 - 22,5

Couplers, screwless, with insulation displacement connection, with exterior cable gland, IP 44

Conductor cross sections:
16 A: 1 - 2,5 mm² / 32 A: 2,5 - 6 mm²

Cable diameters:
16 A: 7,5 - 18,5 mm / 32 A: 10 - 22,5 mm

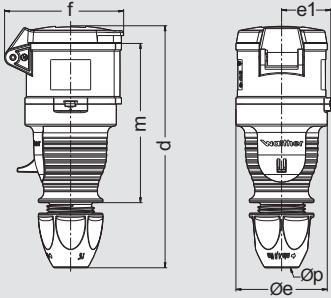

Amp.	16	16	32	32	32
Poles	4	5	3	4	5
d	165-176	165-176	189-199	189-199	189-199
Øe	65	65	72	72	72
e1	35	35	38,5	38,5	38,5
f	77	85	91	91	97
m	114	114	130	130	130
Øp	7,5 - 18,5	7,5 - 18,5	10 - 22,5	10 - 22,5	10 - 22,5

Couplers, screw terminal connection, with exterior cable gland, IP 44

Conductor cross sections:
16 A: 1 - 2,5 mm² / 32 A: 2,5 - 6 mm²

Cable diameters:
16 A: 7,5 - 18,5 mm / 32 A: 10 - 22,5 mm

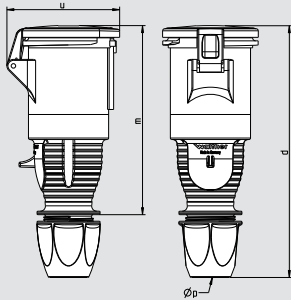

Amp.	63		
Poles	3	4	5
d	261	261	261
u	113	113	113
m	189	189	189
Øp	14-33	14-33	14-33

Couplers, screw terminal connection, with exterior cable gland, IP 44

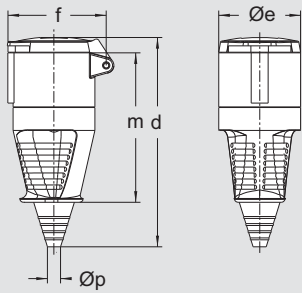

Amp.	16	63		
Poles	3	3	4	5
d	154	266	266	266
Øe	51	96	96	96
f	68	114	114	114
m	109	196	196	196
Øp	7/13	15/33	15/33	15/33

Couplers, screw terminal connection, with flexible cable entry, IP 44

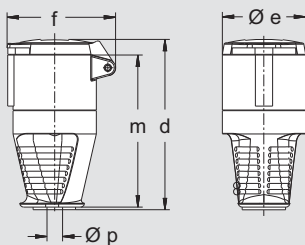

Amp.	16
Poles	3
d	121
Øe	51
f	68
m	108
Øp	8/15

Couplers, screw terminal connection, with inverted cable entry, IP 44

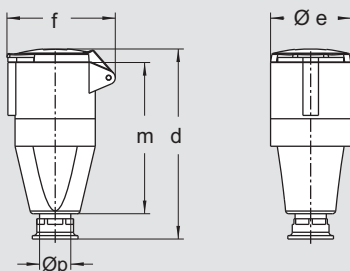

Amp.	16			32			63		
Poles	3	4	5	3	4	5	3	4	5
d	135	151	151	171	171	171	255	255	255
Øe	51	65	65	72	72	72	96	96	96
f	68	85	85	91	91	98	114	114	114
m	110	113	113	136	136	136	194	194	194
Øp	7,5-14,5	7,5-14,5	7,5-14,5	10-19,5	10-19,5	10-19,5	18-34,5	18-34,5	18-34,5

Couplers, screw terminal connection, with trumpet gland, IP 44

Ampère	Poles	110 V 50 a. 60 Hz			230 V 50 a. 60 Hz			400 V 50 a. 60 Hz			500 V 50 a. 60 Hz			> 50 - 500 V 100 - 300 Hz			> 50 - 500 V over 300 - 500 Hz			
		3pole 4h	4pole 4h	5pole 4h	3pole 6h	4pole 9h	5pole 9h	3pole 9h	4pole 6h	5pole 6h	3pole 7h	4pole 7h	5pole 7h	3pole 10h	4pole 10h	5pole 10h	3pole 2h	4pole 2h	5pole 2h	



Part numbers

Ampère	Poles	110 V	230 V	400 V	500 V	> 50 - 500 V	> 50 - 500 V	
16	4	310 404 SL	310 409 SL	310 406 SL	310 407 SL	310 410 SL	310 402 SL	10/60
16	5	310 504 SL	310 509 SL	310SL				10/60
32	3	330 304 SL	330 306 SL	330 309 SL				10/60
32	4	330 404 SL	330 409 SL	330 406 SL	330 407 SL	330 410 SL	330 402 SL	10/60
32	5	330 504 SL	330 509 SL	330 SL				10/60
16	4	310 404	310 409	310 406	310 407	310 410	310 402	10
16	5	310 504	310 509	310				10/60
32	3	330 304	330 306	330 309				10
32	4	330 404	330 409	330 406	330 407	330 410	330 402	10
32	5	330 504	330 509	330				10/60
63	3	362 304	362 306	362 309				5
63	4	362 404	362 409	362 406	362 407	362 410	362 402	5
63	5	362 504	362 509	362				5
63	5			362 Ni				5
16	3	310 304	310 306	310 309				10/60
63	3	360 304	360 306	360 309				5
63	4	360 404	360 409	360 406	360 407	360 410	360 402	5
63	5	360 504	360 509	360				5
63	5			360 Ni				5
16	3	315 304	315 306	315 309				10
16	3	311 304	311 306	311 309				10
16	4	311 404	311 409	311 406	311 407	311 410	311 402	10
16	5	311 504	311 509	311				10
16	5			311 Ni				10
32	3	331 304	331 306	331 309				10
32	4	331 404	331 409	331 406	331 407	331 410	331 402	10
32	5	331 504	331 509	331				10
32	5			331 Ni				10
63	3	361 304	361 306	361 309				5
63	4	361 404	361 409	361 406	361 407	361 410	361 402	5
63	5	361 504	361 509	361				5
63	5			361 Ni				5



4

The here listed 63A couplers are also available with **pilot contact**.
To order them, simply add a "P" behind the standard part number.
Availability of blue printed (or not listed) frequencies and voltages up to 690 V on request!

Couplers
- screwless
- with screw terminals

4

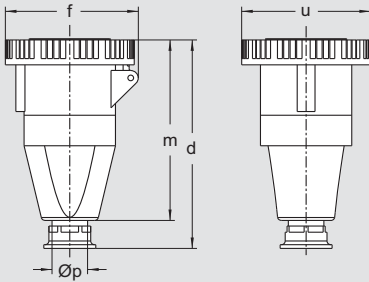

Amp.	16				63			125		
Poles	3	3	4	5	3	4	5	3	4	5
d	136	255	255	255	332	332	332	332	332	332
f	78	117	117	117	130	130	130	130	130	130
m	121	206	206	206	275	275	275	275	275	275
u	72	110	110	110	130	130	130	130	130	130
Øp	7,5 - 14,5	18 - 34,5	18 - 34,5	18 - 34,5	24 - 45	24 - 45	24 - 45	24 - 45	24 - 45	24 - 45

Couplers, screw terminal connection, with trumpet gland, 125 A couplers with Multi-Contact IP 67 ☹☹

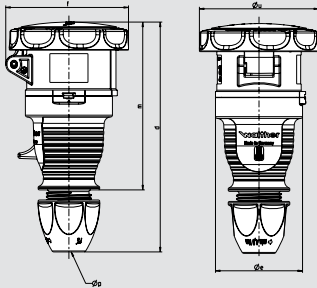

Amp.	16	16	32	32
Poles	4	5	3 / 4	5
d	150-161	150-161	174-183	174-183
Ø e	Ø 65	Ø 65	Ø 72	Ø 72
f	85	92	95	104
m	125	125	142	142
Ø u	Ø 81	Ø 89	Ø 95	Ø 100
Ø p	7,5 - 18,5	7,5 - 18,5	10 - 22,5	10 - 22,5

Couplers, screw terminal connection, with exterior cable gland, IP 67 ☹☹

or

Couplers, screwless („SL“), with insulation displacement connection, with exterior cable gland, IP 67 ☹☹

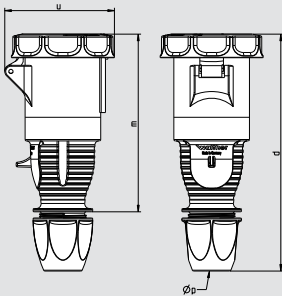

Amp.	63		
Poles	3	4	5
d	261	261	261
u	116	116	116
m	189	189	189
Ø p	14-33	14-33	14-33

Couplers, screw terminal connection, with exterior cable gland, IP 67 ☹☹

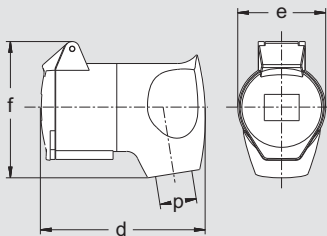

Amp.	16
Poles	3
d	95
e	50,3
f	80
p	8/13

Angled couplers, screw terminal connection, IP 44 ⚠

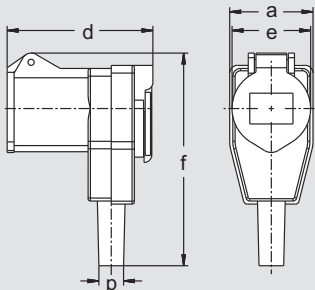

Amp.	16
Poles	3
a	54
d	87
e	49,5
f	140
Øp	7/13

Angled coupler, screw terminal connection, with Schuko socket on reverse side, IP 44 ⚠



A holding plate allows you to suspend a plug/coupler with exterior cable gland from the ceiling.

314 500 = holding plate for 16 A plug/coupler

334 500 = holding plate for 32 A plug/coupler



314 500

Ampère	Poles	110 V 50 a. 60 Hz			230 V 50 a. 60 Hz			400 V 50 a. 60 Hz			500 V 50 a. 60 Hz			> 50 - 500 V 100 - 300 Hz			> 50 - 500 V over 300 - 500 Hz			
		3pole 4h	4pole 4h	5pole 4h	3pole 6h	4pole 9h	5pole 9h	3pole 9h	4pole 6h	5pole 6h	3pole 7h	4pole 7h	5pole 7h	3pole 10h	4pole 10h	5pole 10h	3pole 2h	4pole 2h	5pole 2h	



Part numbers									
16	3	319 304	319 306	319 309					10
16	5			319 Ni					10
32	5			339 Ni					10
63	3	369 304	369 306	369 309					5
63	4	369 404	369 409	369 406	369 407	369 410	369 402		5
63	5	369 504	369 509	369 Ni					5
125	3	379 304	379 306	379 309					2
125	4	379 404	379 409	379 406	379 407	379 410	379 402		2
125	5	379 504	379 509	379 Ni					2
125	5			379 Ni					2
16	4	319 404	319 409	319 406	319 407	319 410	319 402		10
16	5	319 504	319 509	319					10
32	3	339 304	339 306	339 309					10
32	4	339 404	339 409	339 406	339 407	339 410	339 402		10
32	5	339 504	339 509	339					10



Couplers with new design and cable gland. Additionally available as **screwless version** with insulation displacement connection. To order a coupler as screwless version, just add **"SL"** behind the part number.

63	3	368 304	368 306	368 309					10
63	4	368 404	368 409	368 406	368 407	368 410	368 402		10
63	5	368 504	368 509	368					10

16	3	316 304	316 306	316 309					10
----	---	---------	----------------	---------	--	--	--	--	----

16	3		317 306						10
----	---	--	----------------	--	--	--	--	--	----



Padlock
for locking IP 67 plugs and couplers

16 A, 4 and 5 pole and
32 A, 3, 4 and 5 pole

Part no. 501 1



The here listed 63A + 125A couplers are also available with **pilot contact**. To order them, simply add a "P" behind the standard part number.
Availability of blue printed (or not listed) frequencies and voltages up to 690 V on request!

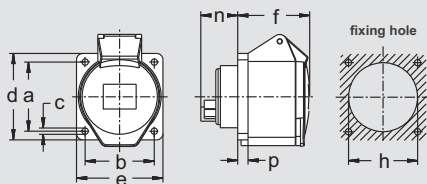

Amp.	16			32		
Poles	3	4	5	3	4	5
a	60	60	60	60	60	60
b	60	60	60	60	60	60
c	5,5	5,5	5,5	5,5	5,5	5,5
d	75	75	75	75	75	75
e	75	75	75	75	75	75
f	52	53	53	65	65	65
h	46	60	60	60	60	60
n	28	28	28	27	27	27
p	6	9	9	9	9	9

Suitable blind flange, part no. 10 015:

a	60
b	60
c	5,2
d	75
e	75
p	6

Panel sockets, straight,
flange dimensions 75 x 75,
fingerproof acc. to BGV A3,
IP 44 ⚠

5

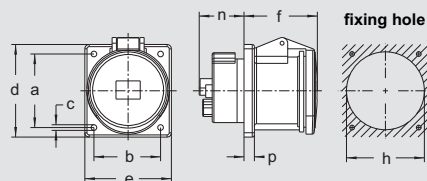

Amp.	63		
Poles	3	4	5
a	85	85	85
b	77	77	77
c	6,5	6,5	6,5
d	107	107	107
e	100	100	100
f	85	85	85
h	90	90	90
n	52	52	52
p	12	12	12

Panel sockets, straight,
flange dimensions 107 x 100,
fingerproof acc. to BGV A3,
IP 44 ⚠

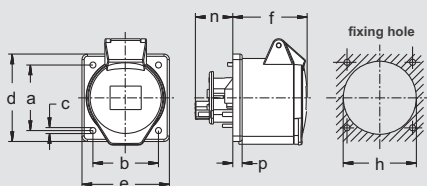

Amp.	16		32		
Poles	4	5	3	4	5
a	60	60	60	60	60
b	60	60	60	60	60
c	5,5	5,5	5,5	5,5	5,5
d	80	80	80	80	80
e	80	80	80	80	80
f	60	60	60	60	60
h	67	67	71	71	71
n	32	32	32	32	32
p	8,5	8,5	8,5	8,5	8,5

Panel sockets, straight,
with screwed flange,
flange dimensions 80 x 80,
fingerproof acc. to BGV A3
(also suitable for cable ducts
with 80 mm cover height),
IP 44 ⚠

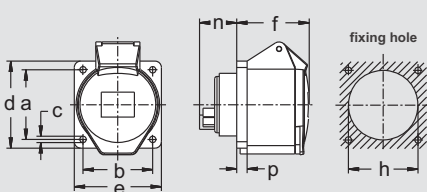

Amp.	16
Poles	3
a	47
b	47
c	5,5
d	62
e	62
f	52
h	46
n	28
p	6

Panel sockets, straight,
flange dimensions 62 x 62,
fingerproof acc. to BGV A3,
IP 44 ⚠

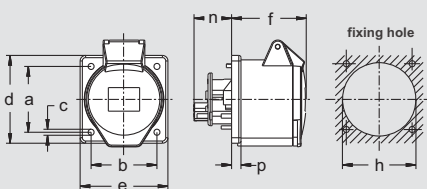

Amp.	16
Poles	3
a	47
b	47
c	5,5
d	62
e	62
f	58
h	50
n	32
p	8,5







Panel sockets, straight,
with screwed flange,
flange dimensions 62 x 62,
fingerproof acc. to BGV A3,
IP 44 ⚠

Panel sockets

Ampère	Poles	110 V 50 a. 60 Hz			230 V 50 a. 60 Hz			400 V 50 a. 60 Hz			500 V 50 a. 60 Hz			> 50 - 500 V 100 - 300 Hz			> 50 - 500 V over 300 - 500 Hz			
		3pole 4h	4pole 4h	5pole 4h	3pole 6h	4pole 9h	5pole 9h	3pole 9h	4pole 6h	5pole 6h	3pole 7h	4pole 7h	5pole 7h	3pole 10h	4pole 10h	5pole 10h	3pole 2h	4pole 2h	5pole 2h	



Part numbers

16	3	411 304	411 306	411 309					10	
16	4	410 404	410 409	410 406	410 407	410 410	410 402	10		
16	5	410 504	410 509	410				10		
16	5			410 Ni				10		
32	3	430 304	430 306	430 309				10		
32	4	430 404	430 409	430 406	430 407	430 410	430 402	10		
32	5	430 504	430 509	430				10		
32	5			430 Ni				10		
63	3	460 304	460 306	460 309				5		
63	4	460 404	460 409	460 406	460 407	460 410	460 402	5		
63	5	460 504	460 509	460				5		
63	5			460 Ni				5		
16	4	411 404	411 409	411 406	411 407	411 410	411 402	10		
16	5	411 504	411 509	411				10		
32	3	431 304	431 306	431 309				10		
32	4	431 404	431 409	431 406	431 407	431 410	431 402	10		
32	5	431 504	431 509	431				10		
16	3	410 304	410 306	410 309				10/60		
16	3	412 304	412 306	412 309				10		

The here listed 63 A panel sockets are also available with **pilot contact**.

To order them, simply add a "P" behind the standard part number.

Availability of blue printed (or not listed) frequencies and voltages up to 690 V on request!

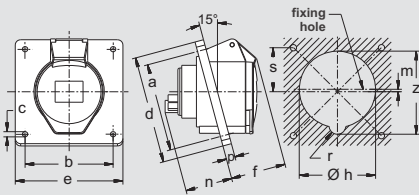

Amp.	16			32		
Poles	3	4	5	3	4	5
a	47	60	60	60	60	70
b	47	60	60	60	60	60
c	5,5	5,5	5,5	5,5	5,5	5,5
d	68	75	85	90	90	95
e	62	75	75	75	75	80
f	45	51	51	52	52	56
h	51	60	68	67	67	76
m	-/-	2	2	-/-	-/-	2,5
n	41	38	38	47	47	47
p	6	9	9	9	9	9
r	6,5	7,5	8	7,5	7,5	8,5
s	-/-	-/-	30	-/-	-/-	35
y	52,5	62	-/-	71	71	-/-
z	57	64	73	76	76	83

Panel sockets, angled,
fingerproof acc. to BGV A3,
IP 44 ▲

5

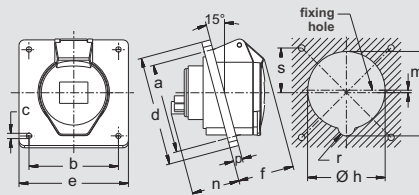

Amp.	16		32			63		
Poles	4	5	3	4	5	3	4	5
a	85	85	85	85	85	85	85	85
b	77	77	77	77	77	77	77	77
c	5,5	5,5	5,5	5,5	5,5	6,5	6,5	6,5
d	100	100	100	100	100	107	100	107
e	92	92	92	92	92	100	92	100
f	51	51	52	52	56	79	79	79
h	75	70	75	75	78	81	81	84
m	2	2	-/-	2,5	2,5	-/-	3	3
n	38	38	47	47	47	64	64	64
p	9	9	9	9	9	12	12	12
r	7,5	7,5	7,5	7,5	8,5	8	8	9
s	42,5	42,5	-/-	42,5	42,5	-/-	42,5	42,5
y	-/-	-/-	80	80	-/-	85	85	-/-
z	85	74	85	85	85	90	90	90

Panel sockets, angled,
fixing dimensions 85 x 77,
fingerproof acc. to BGV A3,
IP 44 ▲

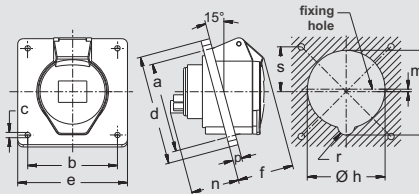

Amp.	16	32	63
Poles	5	5	5
a	90	90	90
b	90	90	90
c	5,5	5,5	6,5
d	110	110	114
e	110	110	114
f	51	56	79
h	70	78	86
m	2	2,5	2,5
n	38	47	64
p	9	9	12
r	7,5	8,5	10
s	45	45	45
z	74	85	94

Panel sockets, angled,
fixing dimensions 90 x 90,
16 - 63 A fingerproof acc. to BGV A3,
IP 44 ▲

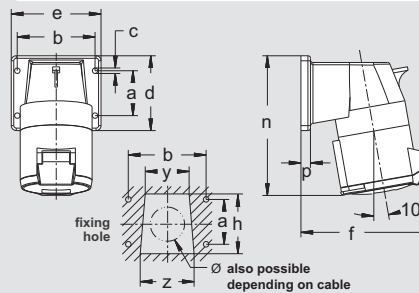

Amp.	16			32		
Poles	3	4	5	3	4	5
a	30	40	40	45	45	45
b	55	68	68	78	78	78
c	5,5	5,5	5,5	5,5	5,5	5,5
d	52	66	66	75	75	75
e	65	80	80	90	90	90
f	87	110	110	120	120	124
h	38	52	52	60	60	60
n	116	122	122	141	141	142
p	9,5	9,5	9,5	9,5	9,5	9,5
y	30	38	38	44	44	44
z	36	46	46	54	54	54

Panel sockets, angled,
with screwed flange enclosure,
IP 44 ▲

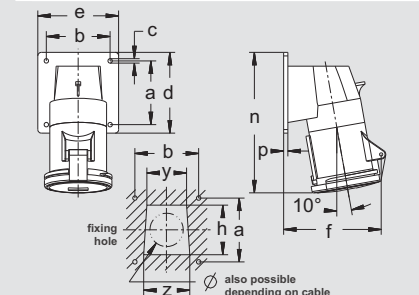

Amp.	63		
Poles	3	4	5
a	90	90	90
b	90	90	90
c	6,2	6,2	6,2
d	114	114	114
e	114	114	114
f	140	140	140
h	70	70	70
n	194	194	194
p	6	6	6
y	56	56	56
z	65	65	65

Panel sockets, angled,
with screwed flange enclosure,
IP 44 ▲

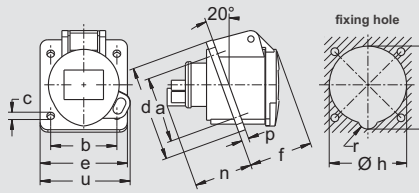

Amp.	16
Poles	3
a	47
b	47
c	5,5
d	68
e	62
f	46
h	55
n	41
p	5
r	5
u	65
z	58

Panel sockets, angled,
with eye for padlock,
for locking with plug
212 306, 212 304 or 212 309,
IP 44 ▲

Ampère	Poles	110 V 50 a. 60 Hz			230 V 50 a. 60 Hz			400 V 50 a. 60 Hz			500 V 50 a. 60 Hz			> 50 - 500 V 100 - 300 Hz			> 50 - 500 V over 300 - 500 Hz			
		3pole 4h	4pole 4h	5pole 4h	3pole 6h	4pole 9h	5pole 9h	3pole 9h	4pole 6h	5pole 6h	3pole 7h	4pole 7h	5pole 7h	3pole 10h	4pole 10h	5pole 10h	3pole 2h	4pole 2h	5pole 2h	



Part numbers

Ampère	Poles	110 V 50 a. 60 Hz	230 V 50 a. 60 Hz	400 V 50 a. 60 Hz	500 V 50 a. 60 Hz	> 50 - 500 V 100 - 300 Hz	> 50 - 500 V over 300 - 500 Hz	
16	3	510 304	510 306	510 309				10
16	4	510 404	510 409	510 406	510 407	510 410	510 402	10
16	5	510 504	510 509	510				10
16	5			510 Ni				10
32	3	530 304	530 306	530 309				10
32	4	530 404	530 409	530 406	530 407	530 410	530 402	10
32	5	530 504	530 509	530				10
32	5			530 Ni				10
16	4	511 404	511 409	511 406	511 407	511 410	511 402	10
16	5	511 504	511 509	511				10
32	3	531 304	531 306	531 309				10
32	4	531 404	531 409	531 406	531 407	531 410	531 402	10
32	5	531 504	531 509	531				10
63	3	560 304	560 306	560 309				5
63	4	560 404	560 409	560 406	560 407	560 410	560 402	5
63	5	560 504	560 509	560				5
63	5			560 Ni				5
16	5	512 504	512 509	512				10
16	5			512 Ni				10
32	5	532 504	532 509	532				10
32	5			532 Ni				10
63	5	562 504	562 509	562				5
63	5			562 Ni				5
16	3	514 304	514 306	514 309				10
16	4	514 404	514 409	514 406	514 407	514 410	514 402	10
16	5	514 504	514 509	514				10
32	3	534 304	534 306	534 309				5
32	4	534 404	534 409	534 406	534 407	534 410	534 402	5
32	5	534 504	534 509	534				5
63	3	564 304	564 306	564 309				5
63	4	564 404	564 409	564 406				5
63	5	564 504	564 509	564				5
16	3	512 304	512 306	512 309				10



5

The here listed 63 A panel sockets are also available with **pilot contact**.
To order them, simply add a "P" behind the standard part number.
Availability of blue printed (or not listed) frequencies and voltages up to 690 V on request!

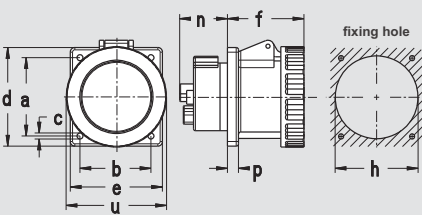

Amp.	16			32			63		
Poles	3	4	5	3	4	5	3	4	5
a	47	60	60	60	60	60	85	85	85
b	47	60	60	60	60	60	77	77	77
c	5,5	5,5	5,5	5,5	5,5	5,5	6,5	6,5	6,5
d	62	75	75	75	75	75	107	107	107
e	62	75	75	75	75	75	100	100	100
f	52	52	52	65	65	65	83	83	83
h	46	60	60	60	60	60	90	90	90
n	28	28	28	27	27	27	52	52	52
p	6	9	9	9	9	9	12	12	12
u	72	81	88	96	96	103	110	110	110

Panel sockets, straight, fingerproof acc. to BGV A3, IP 67

5

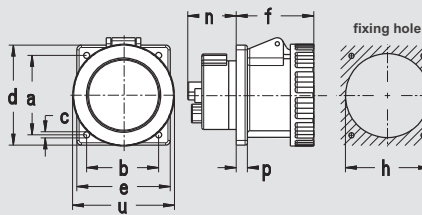

Amp.	125		
Poles	3	4	5
a	90	90	90
b	90	90	90
c	6,5	6,5	6,5
d	114	114	114
e	114	114	114
f	96	96	96
h	90	90	90
n	64	64	64
p	12	12	12
u	130	130	130

Panel sockets, straight, with Multi-Contact, back-of-hand proof acc. to BGV A3, IP 67

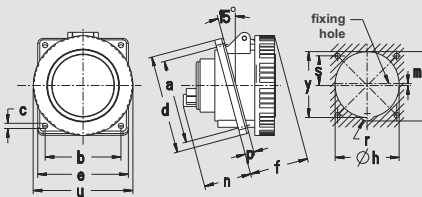

Amp.	16			32			63		
Poles	3	4	5	3	4	5	3	4	5
a	47	85	85	85	85	85	85	85	85
b	47	77	77	77	77	77	77	77	77
c	5,5	5,5	5,5	5,5	5,5	5,5	6,5	6,5	6,5
d	68	100	100	100	100	100	107	107	107
e	62	92	92	92	92	92	100	100	100
f	49	52	52	56	56	60	82	82	82
h	51	73	70	73	73	78	81	81	84
m	-/-	2	2	-/-	2,5	2,5	-/-	2,5	3
n	41	38	38	47	47	47	64	64	64
p	6	9	9	9	9	9	12	12	12
r	6,5	7,5	7,5	7,5	7,5	8,5	8	8	9
s	-/-	42,5	42,5	-/-	42,5	42,5	-/-	42,5	42,5
u	72	81	88	96	96	103	110	110	110
y	53	76	-/-	76	76	-/-	85	85	-/-
z	57	82	74	82	82	85	90	90	90

Panel sockets, angled, fingerproof acc. to BGV A3, IP 67

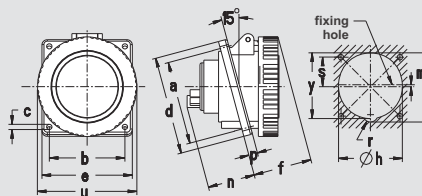

Amp.	125		
Poles	3	4	5
a	90	90	90
b	90	90	90
c	6,5	6,5	6,5
d	114	114	114
e	114	114	114
f	94	94	94
h	90	90	88
m	-/-	8	8
n	75	75	75
p	12	12	12
r	8	8	9,5
s	-/-	45	45
u	130	130	130
y	96	96	96
z	102	102	104

Panel sockets, angled, with Multi-Contact, back-of-hand proof acc. to BGV A3, IP 67

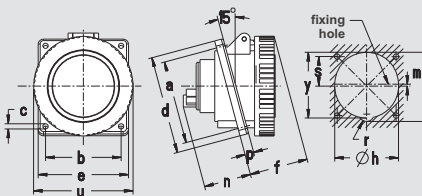

Amp.	16		32		63	
Poles	4	5	3	4	5	5
a	60	60	60	60	70	90
b	60	60	60	60	60	90
c	5,5	5,5	5,5	5,5	5,5	6,5
d	75	85	90	90	95	114
e	75	75	75	75	80	114
f	52	52	56	56	60	72
h	60	68	67	67	76	86
m	-/-	2	-/-	-/-	2,5	2,5
n	38	38	47	47	47	82
p	9	9	9	9	9	6
r	7,5	8	7,5	7,5	8,5	10
s	-/-	30	-/-	-/-	35	45
u	81	88	96	96	103	110
y	62	-/-	71	71	-/-	-/-
z	64	73	76	76	83	94

Panel sockets, angled, fingerproof acc. to BGV A3, IP 67

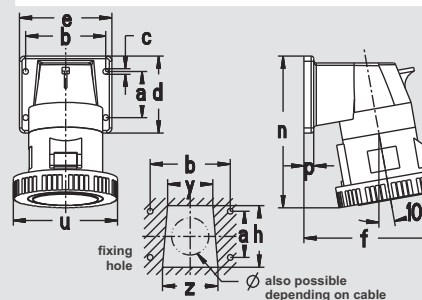

Amp.	16			32			63		
Poles	3	4	5	3	4	5	3	4	5
a	30	40	40	45	45	45	90	90	90
b	55	68	68	78	78	78	90	90	90
c	5,5	5,5	5,5	5,5	5,5	5,5	6,2	6,2	6,2
d	52	66	66	75	75	75	114	114	114
e	65	80	80	90	90	90	114	114	114
f	88	108	108	121	121	123	143	143	143
h	38	52	52	60	60	60	70	70	70
n	109	123	123	145	145	145	203	203	203
p	9,5	9,5	9,5	9,5	9,5	9,5	6	6	6
u	72	81	88	96	96	103	110	110	110
y	30	38	38	44	44	44	56	56	56
z	36	46	46	54	54	54	65	65	65

Panel sockets, angled, with screwed flange enclosure, IP 67

Ampère	Poles	110 V 50 a. 60 Hz			230 V 50 a. 60 Hz			400 V 50 a. 60 Hz			500 V 50 a. 60 Hz			> 50 - 500 V 100 - 300 Hz			> 50 - 500 V over 300 - 500 Hz			
		3pole 4h	4pole 4h	5pole 4h	3pole 6h	4pole 9h	5pole 9h	3pole 9h	4pole 6h	5pole 6h	3pole 7h	4pole 7h	5pole 7h	3pole 10h	4pole 10h	5pole 10h	3pole 2h	4pole 2h	5pole 2h	



		Part numbers																	
16	3	419 304	419 306	419 309														10	
16	4	419 404	419 409	419 406	419 407	419 410	419 402											10	
16	5	419 504	419 509	419														10	
16	5			419 Ni														10	
32	3	439 304	439 306	439 309														10	
32	4	439 404	439 409	439 406	439 407	439 410	439 402											10	
32	5	439 504	439 509	439														10	
32	5			439 Ni														10	
63	3	469 304	469 306	469 309														5	
63	4	469 404	469 409	469 406	469 407	469 410	469 402											5	
63	5	469 504	469 509	469														5	
63	5			469 Ni														5	
125	3	479 304	479 306	479 309														2	
125	4	479 404	479 409	479 406	479 407	479 410	479 402											2	
125	5	479 504	479 509	479														2	
125	5			479 Ni														2	
16	3	519 304	519 306	519 309														10	
16	4	519 404	519 409	519 406	519 407	519 410	519 402											10	
16	5	519 504	519 509	519														10	
16	5			519 Ni														10	
32	3	539 304	539 306	539 309														10	
32	4	539 404	539 409	539 406	539 407	539 410	539 402											10	
32	5	539 504	539 509	539														10	
32	5			539 Ni														10	
63	3	569 304	569 306	569 309														5	
63	4	569 404	569 409	569 406	569 407	569 410	569 402											5	
63	5	569 504	569 509	569														5	
63	5			569 Ni														5	
125	3	579 304	579 306	579 309														2	
125	4	579 404	579 409	579 406	579 407	579 410	579 402											2	
125	5	579 504	579 509	579														2	
125	5			579 Ni														2	
16	4	517 404	517 409	517 406	517 407	517 410	517 402											10	
16	5	517 504	517 509	517														10	
32	3	537 304	537 306	537 309														10	
32	4	537 404	537 409	537 406	537 407	537 410	537 402											10	
32	5	537 504	537 509	537														10	
63	5	567 504	567 509	567														5	
16	3	518 304	518 306	518 309														10	
16	4	518 404	518 409	518 406	518 407	518 410	518 402											10	
16	5	518 504	518 509	518														10	
32	3	538 304	538 306	538 309														10	
32	4	538 404	538 409	538 406	538 407	538 410	538 402											10	
32	5	538 504	538 509	538														10	
63	3	568 304	568 306	568 309														5	
63	4	568 404	568 409	568 406	568 407	568 410	568 402											5	
63	5	568 504	568 509	568														5	

The here listed 63 A and 125 A panel sockets are also available with **pilot contact**.
 To order them, simply add a "P" behind the standard part number.
Availability of blue printed (or not listed) frequencies and voltages up to 690 V on request!

Panel sockets

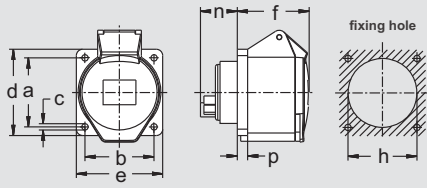

Amp.	16			32		
Poles	3	4	5	3	4	5
a	60	60	60	60	60	60
b	60	60	60	60	60	60
c	5,5	5,5	5,5	5,5	5,5	5,5
d	75	75	75	75	75	75
e	75	75	75	75	75	75
f	52	53	53	65	65	65
h	46	60	60	60	60	60
n	28	28	28	27	27	27
p	6	9	9	9	9	9

Fixing dimensions = a + b

Flange dimensions = d + e





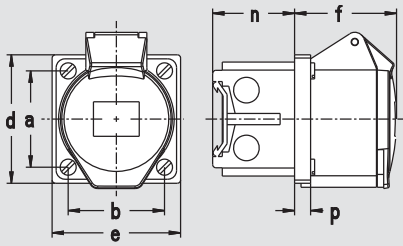



Panel socket, straight, also suitable for cable ducts, cable duct mounting dimensions: 60 x 60 mm IP 44 ⚠

5



Amp.	16			32		
Poles	3	4	5	3	4	5
a	60	60	60	60	60	60
b	60	60	60	60	60	60
d	80	80	80	80	80	80
e	80	80	80	80	80	80
f	56	59	59	62	69	69
n	52	52	52	52	52	52
p	10	10	10	10	10	10

Panel sockets, straight, for switch cabinet installation, junction box mountable on DIN-rail, occupies 4,5 MCB module widths, IP 44 ⚠

Ampère	Poles	110 V 50 a. 60 Hz			230 V 50 a. 60 Hz			400 V 50 a. 60 Hz			500 V 50 a. 60 Hz			> 50 - 500 V 100 - 300 Hz			> 50 - 500 V over 300 - 500 Hz			  2 P + E  3 P + E  3 P + N + E	
		3pole 4h	4pole 4h	5pole 4h	3pole 6h	4pole 9h	5pole 9h	3pole 9h	4pole 6h	5pole 6h	3pole 7h	4pole 7h	5pole 7h	3pole 10h	4pole 10h	5pole 10h	3pole 2h	4pole 2h	5pole 2h		
Part numbers																					
16	3				411 306															10	 430
16	4																			10	
16	5																			10	
32	3				430 306															10	 430 VS
32	4																			10	
32	5																			10	
16	3	411 304 VS			411 306 VS		411 309 VS													10	 430 VS
16	4						410 406 VS	410 407 VS												10	
16	5	410 504 VS			410 509 VS		410 VS													10	
32	3				430 306 VS		430 406 VS													10	 430 VS
32	4						430 VS													10	
32	5	430 504 VS			430 509 VS															10	

Availability of blue printed (or not listed) frequencies and voltages up to 690 V on request!

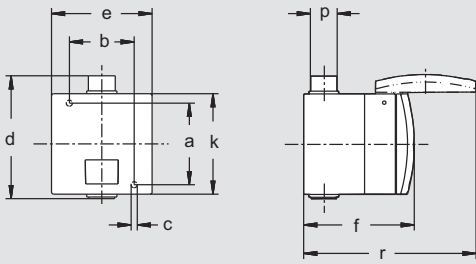

Amp.	16			32		
Poles	3	4	5	3	4	5
d	85	98	98	115	115	115
e	50,3	64,3	64,3	72	72	72
f	70	86	86	96	96	100
n	37	37	37	45,8	45,8	45,8
p	8/15	10/16,5	10/16,5	11/22	11/22	11/22

mondo wall sockets,
surface mount
RAL 7035 light grey,
IP 44 ▲

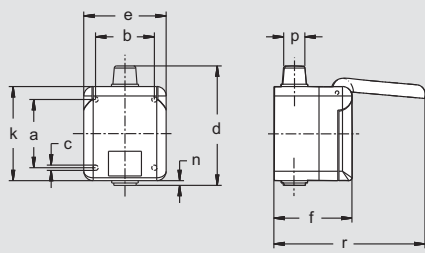

Amp.	16
Poles	3
a	58
b	50
c	4,5
d	98
e	70
f	68
k	80
n	5
p	7/17,5
r	130

mondo wall sockets,
small version, surface mount,
RAL 7035 light grey,
IP 44 ▲

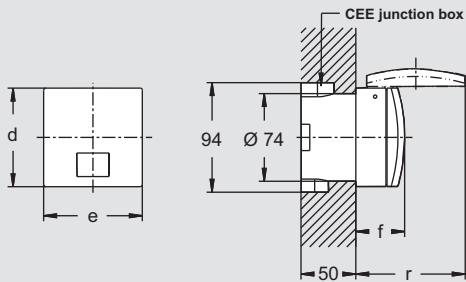

Amp.	16		
Poles	3	4	5
d	90	90	90
e	90	90	90
f	38	38	38
r	96	96	96

mondo wall sockets,
flush mount,
with flush-type junction box,
with plaster compensation, IP 44 ▲

Available in three colours:
RAL 1013 pearl white
RAL 7035 light grey (suffix „LG“)
RAL 9010 clear white (suffix „RW“),

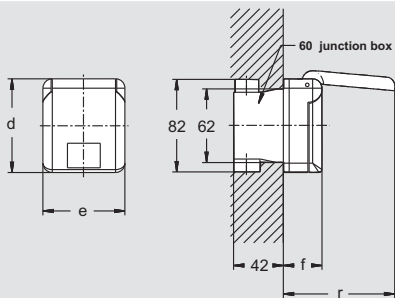

Amp.	16
Poles	3
d	80
e	70
f	33
r	96

mondo wall sockets,
small version, flush mount,
RAL 1013 pearl white
RAL 7035 light grey (with suffix 'LG'),
RAL 9010 clear white (with suffix 'RW'),
with flush-type junction box,
with plaster compensation,
IP 44 ▲

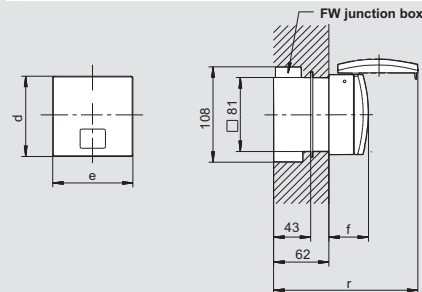

Amp.	32		
Poles	3	4	5
d	90	90	90
e	90	90	90
f	45	45	45
r	104	104	104

mondo wall sockets,
flush mount,
RAL 1013 pearl white,
with flush-type junction box,
with plaster compensation,
IP 44 ▲

Available in three colours:
RAL 1013 pearl white
RAL 7035 light grey (LG)
RAL 9010 clear white (RW)

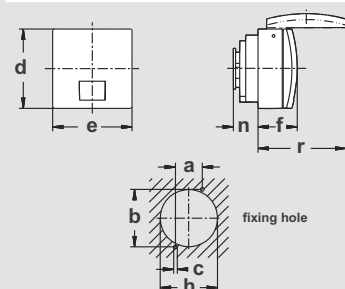

Amp.	16			32		
Poles	3	4	5	3	4	5
a	30,4	30,4	30,4	60	60	60
b	65,2	65,2	65,2	60	60	60
c	4,1	4,1	4,1	4,1	4,1	4,1
d	90	90	90	90	90	90
e	90	90	90	90	90	90
f	38	38	38	45	45	45
h	65	65	65	75	75	75
n	36	36	36	31	31	31
r	96	96	96	104	104	104
z	-/-	-/-	-/-	80	80	80

mondo panel sockets, straight,
IP 44 ▲

Available in three colours:
RAL 7035 light grey,
RAL 9010 clear white (RW),
RAL 1013 pearl white (PW)

Ampère	Poles	110 V 50 a. 60 Hz			230 V 50 a. 60 Hz			400 V 50 a. 60 Hz			500 V 50 a. 60 Hz			> 50 - 500 V 100 - 300 Hz			> 50 - 500 V over 300 - 500 Hz		
		3pole 4h	4pole 4h	5pole 4h	3pole 6h	4pole 9h	5pole 9h	3pole 9h	4pole 6h	5pole 6h	3pole 7h	4pole 7h	5pole 7h	3pole 10h	4pole 10h	5pole 10h	3pole 2h	4pole 2h	5pole 2h



		Part numbers														
16	3	116 304	116 306	116 309											5	
16	4	116 404	116 409	116 406	116 407	116 410	116 402							5		
16	5	116 504	116 509	116										5		
32	3	136 304	136 306	136 309											5	
32	4	136 404	136 409	136 406	136 407	136 410	136 402							5		
32	5	136 504	136 509	136										5		

To order a ... ▶ **... please add the following suffix to the part no.:**

- wall socket with **inscription label** „BS“ e.g. 436 BS
- **lockable wall socket with inscription label** „AS“ e.g. 436 AS

16	3	117 304	117 306	117 309										10	
----	---	---------	----------------	---------	--	--	--	--	--	--	--	--	--	----	--

16	3	416 304	416 306	416 309										10	
16	4	416 404	416 409	416 406	416 407	416 410	416 402						10		
16	5	416 504	416 509	416									10		

To order a ... ▶ **... please add the following suffix to the part no.:**

- wall socket with **inscription label** „BS“ e.g. 436 BS
- **lockable wall socket with inscription label** „AS“ e.g. 436 AS
- **light grey wall socket (RAL 7035)** „LG“ e.g. 436 LG (or 436 BSLG or 436 ASLG)
- **clear white wall socket (RAL 9010)** „RW“ e.g. 436 RW (or 436 BSRW or 436 ASRW)

16	3	418 304	418 306	418 309										10	
16	3		418 306 LG											10	
16	3		418 306 RW											10	

32	3	436 304	436 306	436 309										5	
32	4	436 404	436 409	436 406	436 407	436 410	436 402							5	
32	5	436 504	436 509	436										5	

To order a ... ▶ **... please add the following suffix to the part no.:**

- wall socket with **inscription label** „BS“ e.g. 436 BS
- **lockable wall socket with inscription label** „AS“ e.g. 436 AS
- **light grey wall socket (RAL 7035)** „LG“ e.g. 436 LG (or 436 BSLG or 436 ASLG)
- **clear white wall socket (RAL 9010)** „RW“ e.g. 436 RW (or 436 BSRW or 436 ASRW)

16	3	415 304	415 306	415 309										10	
16	4	415 404	415 409	415 406	415 407	415 410	415 402							10	
16	5	415 504	415 509	415										10	
32	3	435 304	435 306	435 309										10	
32	4	435 404	435 409	435 406	435 407	435 410	435 402							10	
32	5	435 504	435 509	435										10	

To order a ... ▶ **... please add the following suffix to the part no.:**

- wall socket with **inscription label** „BS“ e.g. 436 BS
- **lockable wall socket with inscription label** „AS“ e.g. 436 AS

Availability of blue printed (or not listed) frequencies and voltages up to 690 V on request!

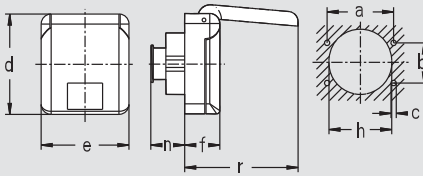

Amp.	16
Poles	3
a	53
b	32
c	4,2
d	80
e	70
f	28
h	50
n	29
r	91

Fixing dimensions = a + b,
Flange dimensions = d + e

**mondo panel sockets,
also suitable for cable ducts,**
RAL 7035 light grey,
RAL 1013 pearl white (suffix „PW“),
RAL 9010 clear white (suffix „RW“),
IP 44 ▲

- Only possible with cover plate 10 028 -

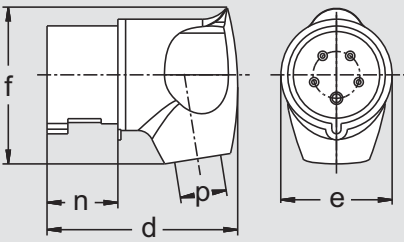

Amp.	16			32		
Poles	3	4	5	3	4	5
d	85	98	98	115	115	115
e	50,3	64,3	64,3	72	72	72
f	70	86	86	96	96	100
n	37	37	37	45,8	45,8	45,8
p	8/15	10/16,5	10/16,5	11/22	11/22	11/22

**mondo angled plug,
screw terminal connection,**
back shell RAL 7035 light grey,
IP 44 ▲

inscription label

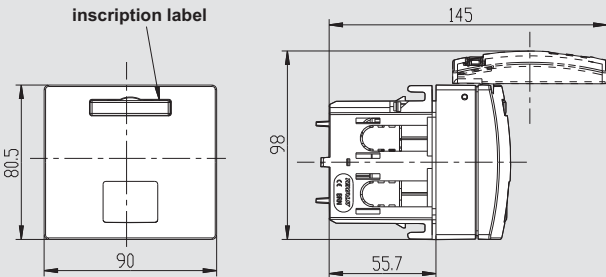

**mondo sockets for cable ducts, IP 44
for TEHALIT steel sheet cable ducts,
with inscription label**

Available in four colours:

- RAL 7035 light grey,
- RAL 9010 clear white (suffix „RW“),
- RAL 9001 cream white (suffix „CW“)
- lacquered aluminium (suffix „LA“)

inscription label

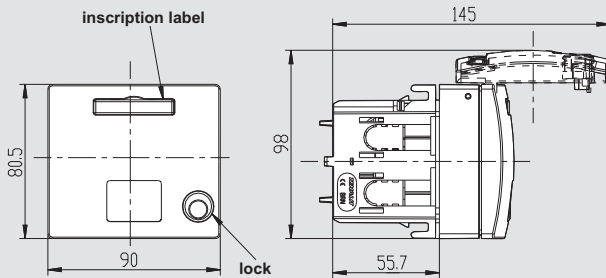

**mondo sockets for cable ducts, IP 44
for TEHALIT steel sheet cable ducts,
with inscription label and lock**

Available in four colours:

- RAL 7035 light grey,
- RAL 9010 clear white (suffix „RW“),
- RAL 9001 cream white (suffix „CW“)
- lacquered aluminium (suffix „LA“)

inscription label

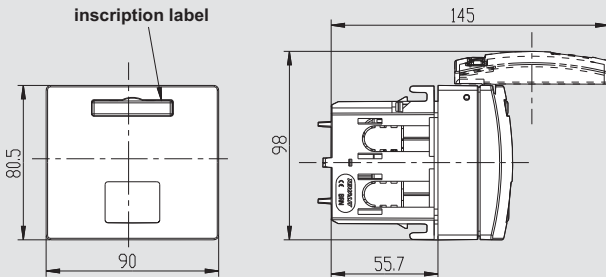

**mondo sockets for cable ducts, IP 44
for TEHALIT plastic cable ducts,
with inscription label**

Available in four colours:

- RAL 7035 light grey,
- RAL 9010 clear white (suffix „RW“),
- RAL 9001 cream white (suffix „CW“)
- lacquered aluminium (suffix „LA“)

inscription label

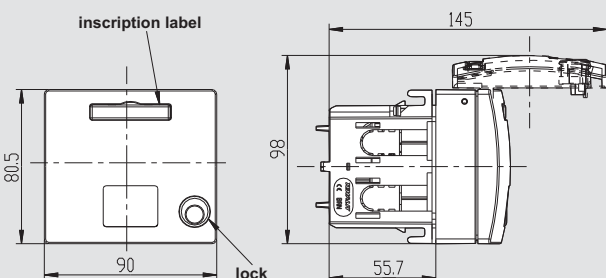

**mondo sockets f. cable ducts, IP 44
for TEHALIT plastic cable ducts,
with inscription label and lock**

Available in four colours:

- RAL 7035 light grey,
- RAL 9010 clear white (suffix „RW“),
- RAL 9001 cream white (suffix „CW“)
- lacquered aluminium (suffix „LA“)

Ampère	Poles	110 V 50 a. 60 Hz			230 V 50 a. 60 Hz			400 V 50 a. 60 Hz			500 V 50 a. 60 Hz			> 50 - 500 V 100 - 300 Hz			> 50 - 500 V over 300 - 500 Hz		
		3pole 4h	4pole 4h	5pole 4h	3pole 6h	4pole 9h	5pole 9h	3pole 9h	4pole 6h	5pole 6h	3pole 7h	4pole 7h	5pole 7h	3pole 10h	4pole 10h	5pole 10h	3pole 2h	4pole 2h	5pole 2h



		Part numbers																		
16	3	417 304	417 306	417 309														10		
16	3		417 306 PW															10		
16	3		417 306 RW															10		
16	3	216 304	216 306	216 309														10		
16	4	216 404	216 409	216 406					216 407	216 410	216 402						10			
16	5	216 504	216 509	216													10/60			
32	3	236 304	236 306	236 309														10		
32	4	236 404	236 409	236 406					236 407	236 410	236 402						10			
32	5	236 504	236 509	236													10			
Also available in pearl white and clear white : For pearl white add "PW" behind the part number, for clear white "RW"																				
16	3		400 306	400 406														10		
16	4			400														10		
16	5																	10		
16	3		400 306 RW	400 406 RW														10		
16	4			400 RW														10		
16	5																	10		
16	3		400 306 CW	400 406 CW														10		
16	4			400 CW														10		
16	5																	10		
16	3		400 306 LA	400 406 LA														10		
16	4			400 LA														10		
16	5																	10		
 cable duct sockets																				
16	3		402 306	402 406														10		
16	4			402														10		
16	5																	10		
16	3		402 306 RW	402 406 RW														10		
16	4			402 RW														10		
16	5																	10		
16	3		402 306 CW	402 406 CW														10		
16	4			402 CW														10		
16	5																	10		
16	3		402 306 LA	402 406 LA														10		
16	4			402 LA														10		
16	5																	10		
for																				
16	3		401 306	401 406														10		
16	4			401														10		
16	5																	10		
16	3		401 306 RW	401 406 RW														10		
16	4			401 RW														10		
16	5																	10		
16	3		401 306 CW	401 406 CW														10		
16	4			401 CW														10		
16	5																	10		
16	3		401 306 LA	401 406 LA														10		
16	4			401 LA														10		
16	5																	10		
TEHALIT cable ducts, series BR, BRN and BRA																				
16	3		403 306	403 406														10		
16	4			403														10		
16	5																	10		
16	3		403 306 RW	403 406 RW														10		
16	4			403 RW														10		
16	5																	10		
16	3		403 306 CW	403 406 CW														10		
16	4			403 CW														10		
16	5																	10		
16	3		403 306 LA	403 406 LA														10		
16	4			403 LA														10		
16	5																	10		

Availability of blue printed (or not listed) frequencies and voltages up to 690 V on request!

Wall sockets with switch

- with interlocking
- without interlocking

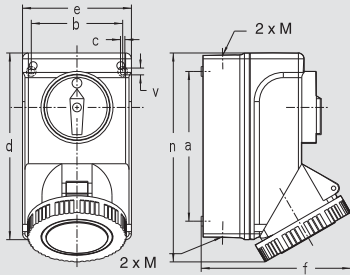

Amp. Poles	16			32		
	3	4	5	3	4	5
a	127	127	127	154	154	154
b	78	78	78	94	94	94
b1	/	/	/	/	/	/
c	4,5	4,5	4,5	4,5	4,5	4,5
d	166	166	166	193	193	193
e	97	97	97	113	113	113
f (IP 44)	116	120	125	145	145	148
f (IP 67)	120	125	132	154	154	154
n (IP 44)	185	185	185	215	215	215
n (IP 67)	185	185	185	215	215	215
v	7	7	7	7	7	7
M	20	20	20	25	25	25

Wall sockets, 3-pole,
with switch, with interlocking, IP 44
• I/O switch 2-pole

Wall sockets, 4-pole,
with switch, with interlocking, IP 44
• I/O switch 4-pole

Wall sockets, 5-pole,
with switch, with interlocking, IP 44
• I/O switch 4-pole

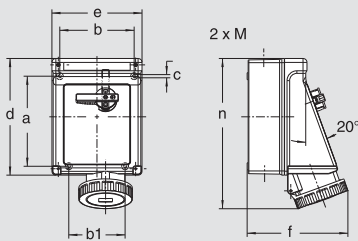

Amp. Poles	16			32			63		
	3	4	5	3	4	5	3	4	5
a	183	183	183	183	183	183	183	183	183
b	151	151	151	151	151	151	151	151	151
b1	114	114	114	114	114	114	114	114	114
c	6,5	6,5	6,5	6,5	6,5	6,5	6,5	6,5	6,5
d	237	237	237	237	237	237	237	237	237
e	183	183	183	183	183	183	183	183	183
f (IP 44)	182	187	184	187	187	189	196	196	196
f (IP 67)	193	194	196	201	201	201	209	209	209
n (IP 44)	268	270	273	282	282	284	302	302	302
n (IP 67)	270	272	277	285	285	289	309	309	309
v	/	/	/	/	/	/	/	/	/
M	25/32	25/32	25/32	25/32	25/32	25/32	25/32	25/32	25/32

Wall sockets, 3-pole,
with switch, with interlocking, IP 44
• I/O switch 2-pole

Wall sockets, 4-pole,
with switch, with interlocking, IP 44
• I/O switch 3-pole

Wall sockets, 5-pole,
with switch, with interlocking, IP 44
• I/O switch 4-pole

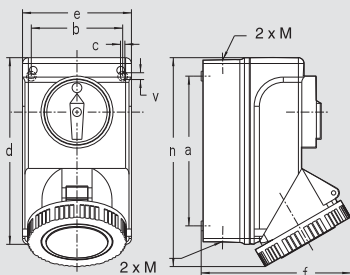

Amp. Poles	16			32		
	3	4	5	3	4	5
a	127	127	127	154	154	154
b	78	78	78	94	94	94
b1	/	/	/	/	/	/
c	4,5	4,5	4,5	4,5	4,5	4,5
d	166	166	166	193	193	193
e	97	97	97	113	113	113
f (IP 44)	116	120	125	145	145	148
f (IP 67)	120	125	132	154	154	154
n (IP 44)	185	185	185	215	215	215
n (IP 67)	185	185	185	215	215	215
v	7	7	7	7	7	7
M	20	20	20	25	25	25

Wall sockets, 3-pole,
with switch, with interlocking, IP 67
• I/O switch 2-pole

Wall sockets, 4-pole,
with switch, with interlocking, IP 67
• I/O switch 3-pole

Wall sockets, 5-pole,
with switch, with interlocking, IP 67
• I/O switch 4-pole

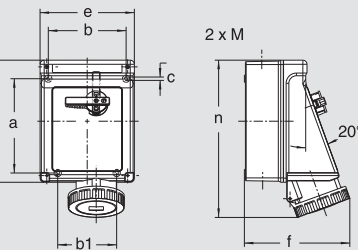

Amp. Poles	16			32			63		
	3	4	5	3	4	5	3	4	5
a	183	183	183	183	183	183	183	183	183
b	151	151	151	151	151	151	151	151	151
b1	114	114	114	114	114	114	114	114	114
c	6,5	6,5	6,5	6,5	6,5	6,5	6,5	6,5	6,5
d	237	237	237	237	237	237	237	237	237
e	183	183	183	183	183	183	183	183	183
f (IP 44)	182	187	184	187	187	189	196	196	196
f (IP 67)	193	194	196	201	201	201	209	209	209
n (IP 44)	268	270	273	282	282	284	302	302	302
n (IP 67)	270	272	277	285	285	289	309	309	309
v	/	/	/	/	/	/	/	/	/
M	25/32	25/32	25/32	25/32	25/32	25/32	25/32	25/32	25/32

Wall sockets, 3-pole,
with switch, with interlocking, IP 67
• I/O switch 2-pole

Wall sockets, 4-pole,
with switch, with interlocking, IP 67
• I/O switch 3-pole

Wall sockets, 5-pole,
with switch, with interlocking, IP 67
• I/O switch 4-pole

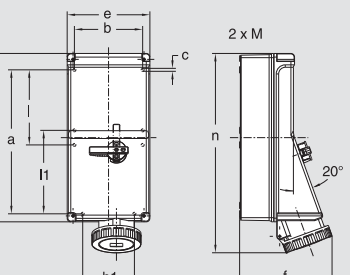

Amp. Poles	16			32			63		
	3	4	5	3	4	5	3	4	5
a	316	316	316	316	316	316	316	316	316
b	151	151	151	151	151	151	151	151	151
b1	114	114	114	114	114	114	114	114	114
c	6,5	6,5	6,5	6,5	6,5	6,5	6,5	6,5	6,5
d	370	370	370	370	370	370	370	370	370
e	183	183	183	183	183	183	183	183	183
f (IP44)	182	187	184	187	187	189	196	196	196
f (IP67)	193	194	196	201	201	201	209	209	209
l	165	165	165	165	165	165	165	165	165
ll	183	183	183	183	183	183	183	183	183
n (IP44)	401	404	405	415	415	417	432	432	432
n (IP67)	404	405	410	418	418	418	443	443	443
M	25/32	25/32	25/32	25/32	25/32	25/32	25/32	25/32	25/32

Wall sockets, 3-pole,
with switch, with interlocking, IP 44
• I/O switch 2-pole

Wall sockets, 4-pole,
with switch, with interlocking, IP 44
• I/O switch 3-pole

Wall sockets, 5-pole,
with switch, with interlocking, IP 44
• I/O switch 4-pole

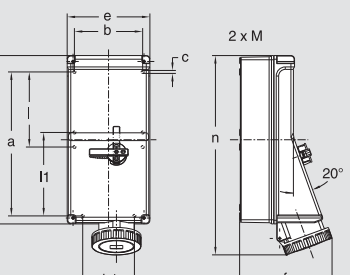

Amp. Poles	16			32			63		
	3	4	5	3	4	5	3	4	5
a	316	316	316	316	316	316	316	316	316
b	151	151	151	151	151	151	151	151	151
b1	114	114	114	114	114	114	114	114	114
c	6,5	6,5	6,5	6,5	6,5	6,5	6,5	6,5	6,5
d	370	370	370	370	370	370	370	370	370
e	183	183	183	183	183	183	183	183	183
f (IP44)	182	187	184	187	187	189	196	196	196
f (IP67)	193	194	196	201	201	201	209	209	209
l	165	165	165	165	165	165	165	165	165
ll	183	183	183	183	183	183	183	183	183
n (IP44)	401	404	405	415	415	417	432	432	432
n (IP67)	404	405	410	418	418	418	443	443	443
M	25/32	25/32	25/32	25/32	25/32	25/32	25/32	25/32	25/32

Wall sockets, 3-pole,
with switch, with interlocking, IP 67
• I/O switch 2-pole

Wall sockets, 4-pole,
with switch, with interlocking, IP 67
• I/O switch 3-pole







Wall sockets, 5-pole,
with switch, with interlocking, IP 67
• I/O switch 4-pole

Switched wall sockets

Ampère	Poles	110 V 50 a. 60 Hz			230 V 50 a. 60 Hz			400 V 50 a. 60 Hz			500 V 50 a. 60 Hz		
		3pole 4h	4pole 4h	5pole 4h	3pole 6h	4pole 9h	5pole 9h	3pole 9h	4pole 6h	5pole 6h	3pole 7h	4pole 7h	5pole 7h

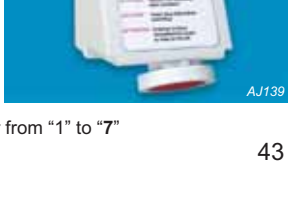

Part numbers

16	3	AT 110 304	AT 110 306	AT 110 309		 AT130
16	4	AT 110 404	AT 110 409	AT 110 406	AT 110 407	
16	5	AT 110 504	AT 110 509	AT 110		
32	3	AT 130 304	AT 130 306	AT 130 309		 AT130
32	4	AT 130 404	AT 130 409	AT 130 406	AT 130 407	
32	5	AT 130 504	AT 130 509	AT 130		
63	3	AE 160 304	AE 160 306	AE 160 309		 AE130
63	4	AE 160 404	AE 160 409	AE 160 406	AE 160 407	
63	5	AE 160 504	AE 160 509	AE 160		
16	3	AT 119 304	AT 119 306	AT 119 309		 AT139
16	4	AT 119 404	AT 119 409	AT 119 406	AT 119 407	
16	5	AT 119 504	AT 119 509	AT 119		
32	3	AT 139 304	AT 139 306	AT 139 309		 AT139
32	4	AT 139 404	AT 139 409	AT 139 406	AT 139 407	
32	5	AT 139 504	AT 139 509	AT 139		
63	3	AE 169 304	AE 169 306	AE 169 309		 AE139
63	4	AE 169 404	AE 169 409	AE 169 406	AE 169 407	
63	5	AE 169 504	AE 169 509	AE 169		
16	3	AJ 110 304	AJ 110 306	AJ 110 309		 AJ130
16	4	AJ 110 404	AJ 110 409	AJ 110 406	AJ 110 407	
16	5	AJ 110 504	AJ 110 509	AJ 110		
32	3	AJ 130 304	AJ 130 306	AJ 130 309		 AJ130
32	4	AJ 130 404	AJ 130 409	AJ 130 406	AJ 130 407	
32	5	AJ 130 504	AJ 130 509	AJ 130		
63	3	AJ 160 304	AJ 160 306	AJ 160 309		 AJ139
63	4	AJ 160 404	AJ 160 409	AJ 160 406	AJ 160 407	
63	5	AJ 160 504	AJ 160 509	AJ 160		
16	3	AJ 119 304	AJ 119 306	AJ 119 309		 AJ139
16	4	AJ 119 404	AJ 119 409	AJ 119 406	AJ 119407	
16	5	AJ 119 504	AJ 119 509	AJ 119		
32	3	AJ 139 304	AJ 139 306	AJ 139 309		 AJ139
32	4	AJ 139 404	AJ 139 409	AJ 139 406	AJ 139 407	
32	5	AJ 139 504	AJ 139 509	AJ 139		
63	3	AJ 169 304	AJ 169 306	AJ 169 309		 AJ169
63	4	AJ 169 404	AJ 169 409	AJ 169 406	AJ 169 407	
63	5	AJ 169 504	AJ 169 509	AJ 169		

On request: If the **neutral conductor** shall be **switched**, change the third digit of the part number from "1" to "7"

Wall sockets with switch

- with interlocking
- without interlocking

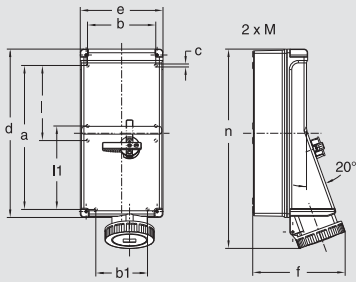

Amp. Poles	125		
	3	4	5
a	316	316	316
b	151	151	151
b1	126	126	126
c	6,5	6,5	6,5
d	370	370	370
e	183	183	183
f (IP44)	/	/	/
f (IP67)	243	243	243
l	/	/	/
ll	/	/	/
n (IP44)	/	/	/
n (IP67)	450	450	450
M	40	40	40

Wall sockets, 3-pole,
with switch, with interlocking, IP 67

- I/O switch 2-pole

Wall sockets, 4-pole,
with switch, with interlocking, IP 67

- I/O switch 3-pole

Wall sockets, 5-pole,
with switch, with interlocking, IP 67

- I/O switch 4-pole

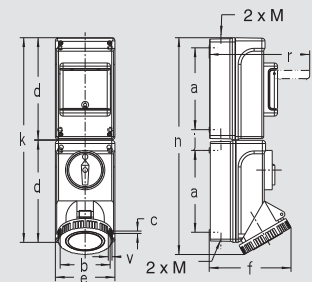

Amp. Poles	16			32		
	3	4	5	3	4	5
a	127	127	127	154	154	154
b	78	78	78	94	94	94
c	4,5	4,5	4,5	4,5	4,5	4,5
d	166	166	166	193	193	193
e	97	97	97	113	113	113
f (IP 44)	116	120	125	145	145	148
f (IP 67)	120	125	132	154	154	154
j	39	39	39	39	39	39
k	333	333	333	387	387	387
n (IP 44)	352	352	352	409	409	409
n (IP 67)	352	352	352	409	409	409
r	177	177	177	191	191	191
v	7	7	7	7	7	7
M	20	20	20	25	25	25

Wall sockets, 3-pole,
with DIN rail, with interlocking, IP 67

- I/O switch 2-pole,

Wall sockets, 4-pole,
with DIN rail, with interlocking, IP 67

- I/O switch 3-pole

Wall sockets, 5-pole,
with DIN rail, with interlocking, IP 67

- I/O switch 4-pole

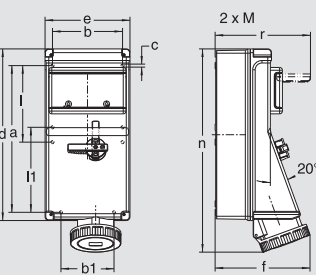

Amp. Poles	16			32			63		
	3	4	5	3	4	5	3	4	5
a	316	316	316	316	316	316	316	316	316
b	151	151	151	151	151	151	151	151	151
b1	114	114	114	114	114	114	114	114	114
c	6,5	6,5	6,5	6,5	6,5	6,5	6,5	6,5	6,5
d	370	370	370	370	370	370	370	370	370
e	183	183	183	183	183	183	183	183	183
f (IP 44)	182	187	184	187	187	189	196	196	196
f (IP 67)	193	194	196	201	201	201	209	209	209
l	165	165	165	165	165	165	165	165	165
ll	183	183	183	183	183	183	183	183	183
n (IP 44)	401	404	405	415	415	417	432	432	432
n (IP 67)	404	405	410	418	418	418	443	443	443
r	206	206	206	206	206	206	206	206	206
M	25/32	25/32	25/32	25/32	25/32	25/32	25/32	25/32	25/32

Wall sockets, 3-pole,
with DIN rail, with interlocking, IP 67

- I/O switch 2-pole

Wall sockets, 4-pole,
with DIN rail, with interlocking, IP 67

- I/O switch 3-pole

Wall sockets, 5-pole,
with DIN rail, with interlocking, IP 67

- I/O switch 4-pole

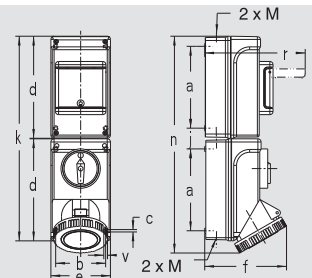

Amp. Poles	16			32		
	3	4	5	3	4	5
a	127	127	127	154	154	154
b	78	78	78	94	94	94
c	4,5	4,5	4,5	4,5	4,5	4,5
d	166	166	166	193	193	193
e	97	97	97	113	113	113
f (IP 44)	116	120	125	145	145	148
f (IP 67)	120	125	132	154	154	154
j	39	39	39	39	39	39
k	333	333	333	387	387	387
n (IP 44)	352	352	352	409	409	409
n (IP 67)	352	352	352	409	409	409
r	177	177	177	191	191	191
v	7	7	7	7	7	7
M	20	20	20	25	25	25

Wall sockets, 3-pole, interlocking, IP 44

- I/O switch 2-pole
- with MCB 1-pole 16 or 32 A »C«

Wall sockets, 4-pole, interlocking, IP 44

- I/O switch 3-pole
- with MCB 3-pole 16 od. 32 A »C«

Wall sockets, 5-pole, interlocking, IP 44

- I/O switch 4-pole
- with MCB 3-pole 16 or 32 A

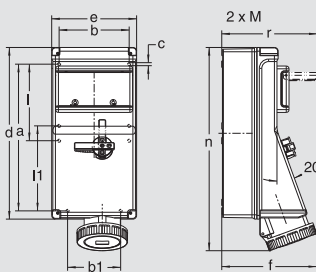

Amp. Poles	16			32			63		
	3	4	5	3	4	5	3	4	5
a	316	316	316	316	316	316	316	316	316
b	151	151	151	151	151	151	151	151	151
b1	114	114	114	114	114	114	114	114	114
c	6,5	6,5	6,5	6,5	6,5	6,5	6,5	6,5	6,5
d	370	370	370	370	370	370	370	370	370
e	183	183	183	183	183	183	183	183	183
f (IP 44)	182	187	184	187	187	189	196	196	196
f (IP 67)	193	194	196	201	201	201	209	209	209
l	165	165	165	165	165	165	165	165	165
ll	183	183	183	183	183	183	183	183	183
n (IP 44)	401	404	405	415	415	417	432	432	432
n (IP 67)	404	405	410	418	418	418	443	443	443
r	206	206	206	206	206	206	206	206	206
M	25/32	25/32	25/32	25/32	25/32	25/32	25/32	25/32	25/32

Wall sockets, 5-pole interlocking, IP 44

- with I/O switch 4-pole,
- with MCB 3-pole 16 A, 32 A or 63 A »C«
- with RCD 4-pole 40 A/30 mA or 63 A/30 mA

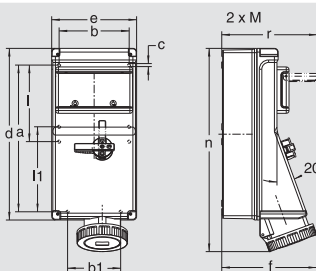

Amp. Poles	16			32			63		
	3	4	5	3	4	5	3	4	5
a	316	316	316	316	316	316	316	316	316
b	151	151	151	151	151	151	151	151	151
b1	114	114	114	114	114	114	114	114	114
c	6,5	6,5	6,5	6,5	6,5	6,5	6,5	6,5	6,5
d	370	370	370	370	370	370	370	370	370
e	183	183	183	183	183	183	183	183	183
f (IP 44)	182	187	184	187	187	189	196	196	196
f (IP 67)	193	194	196	201	201	201	209	209	209
l	165	165	165	165	165	165	165	165	165
ll	183	183	183	183	183	183	183	183	183
n (IP 44)	401	404	405	415	415	417	432	432	432
n (IP 67)	404	405	410	418	418	418	443	443	443
r	206	206	206	206	206	206	206	206	206
M	25/32	25/32	25/32	25/32	25/32	25/32	25/32	25/32	25/32

Wall sockets, 5-pole interlocking, IP 67

- with 4-pole I/O switch,
- with MCB 3-pole 16 A, 32 A or 63 A »C«
- with RCD 4-pole 40 A/30 mA or 63 A/30 mA

Switched wall sockets

Ampère	Poles	110 V 50 a. 60 Hz			230 V 50 a. 60 Hz			400 V 50 a. 60 Hz			500 V 50 a. 60 Hz		
		3pole 4h	4pole 4h	5pole 4h	3pole 6h	4pole 9h	5pole 9h	3pole 9h	4pole 6h	5pole 6h	3pole 7h	4pole 7h	5pole 7h



Part numbers					
125	3	AO 179 304	AO 179 306	AO 179 309	AO 179 407
125	4	AO 179 404	AO 179 409	AO 179 406	
125	5	AO 179 504	AO 179 509	AO 179	
16	3	AU 119 304 TS	AU 119 306 TS	AU 119 309 TS	AU 119 407 TS
16	4	AU 119 404 TS	AU 119 409 TS	AU 119 406 TS	
16	5	AU 119 504 TS	AU 119 509 TS	AU 119 TS	
32	3	AU 139 304 TS	AU 139 306 TS	AU 139 309 TS	AU 139 407 TS
32	4	AU 139 404 TS	AU 139 409 TS	AU 139 406 TS	
32	5	AU 139 504 TS	AU 139 509 TS	AU 139 TS	
16	3	AL 119 304 TS	AL 119 306 TS	AL 119 309 TS	AL 119 407 TS
16	4	AL 119 404 TS	AL 119 409 TS	AL 119 406 TS	
16	5	AL 119 504 TS	AL 119 509 TS	AL 119 TS	
32	3	AL 139 304 TS	AL 139 306 TS	AL 139 309 TS	AL 139 407 TS
32	4	AL 139 404 TS	AL 139 409 TS	AL 139 406 TS	
32	5	AL 139 504 TS	AL 139 509 TS	AL 139 TS	
63	3	AL 169 304 TS	AL 169 306 TS	AL 169 309 TS	AL 169 407 TS
63	4	AL 169 404 TS	AL 169 409 TS	AL 169 406 TS	
63	5	AL 169 504 TS	AL 169 509 TS	AL 169 TS	
16	3	AU 110 304 UD	AU 110 306 UD	AU 110 309 UD	AU 110 407 SA
16	4	AU 110 404 SA	AU 110 409 SA	AU 110 406 SA	
16	5	AU 110 504 TA	AU 110 509 TA	AU 110 TA	
32	3	AU 130 304 UD	AU 130 306 UD	AU 130 309 UD	AU 130 407 SA
32	4	AU 130 404 SA	AU 130 409 SA	AU 130 406 SA	
32	5	AU 130 504 TA	AU 130 509 TA	AU 130 TA	
16	5	AL 110 504 TH	AL 110 509 TH	AL 110 TH	AL 110 TH
32	5	AL 130 504 TH	AL 130 509 TH	AL 130 TH	
63	5	AL 160 504 TH	AL 160 509 TH	AL 160 TH	
16	5	AL 119 504 TH	AL 119 509 TH	AL 119 TH	AL 119 TH
32	5	AL 139 504 TH	AL 139 509 TH	AL 139 TH	
63	5	AL 169 504 TH	AL 169 509 TH	AL 169 TH	



7

On request: If the **neutral conductor** shall be **switched**, change the third digit of the part number from "1" to "7"

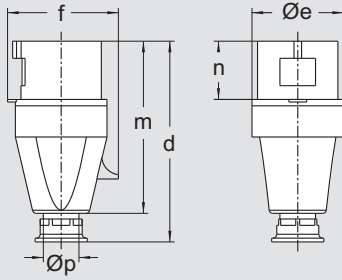

Amp.	16			32			63		
Poles	3	4	5	3	4	5	3	4	5
d	123	131	131	155	155	155	240	240	240
Øe	51	65	65	73	73	73	81	81	81
f	60	68	75	79	79	88	97	97	97
m	118	112	112	133	133	133	192	192	192
n	37	37	37	46	46	46	67	67	67
Øp	7,5-14,5	7,5-14,5	7,5-14,5	10-19,5	10-19,5	10-19,5	18-34,5	18-34,5	18-34,5

Coupler
for light and stage engineering,
with trumpet gland,
16 - 63 A: IP 44 ▲
125 A: IP 67 ●²⁾

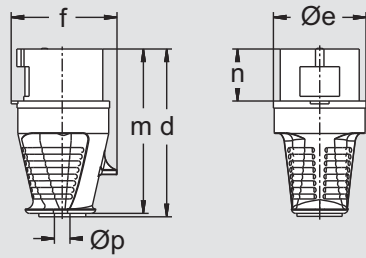

Amp.	16
Poles	5
d	111
Øe	51
f	60
m	108
Øp	8/15

Plug
for light and stage engineering,
with inverted cable entry,
IP 44 ▲

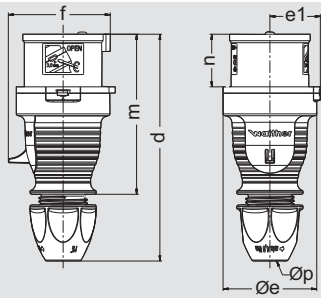

Amp.	16	32
Poles	5	5
d	150-161	174-183
Øe	65	72
e1	35	38,5
f	71	83
m	111	128
n	37	45,5
Øp	7,5-18,5	10-22,5

Plug
for light and stage engineering,
with exterior cable gland,
IP 44 ▲

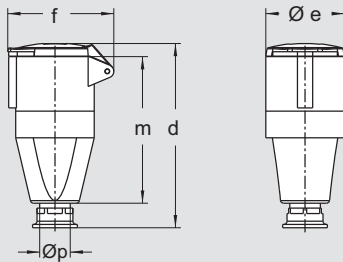

Amp.	16			32			63		
Poles	3	4	5	3	4	5	3	4	5
d	135	151	151	171	171	171	255	255	255
Øe	51	65	65	72	72	72	96	96	96
f	68	85	85	91	91	98	114	114	114
m	110	113	113	136	136	136	194	194	194
Øp	7,5-14,5	7,5-14,5	7,5-14,5	10-19,5	10-19,5	10-19,5	18-34,5	18-34,5	18-34,5

Coupler
for light and stage engineering,
with trumpet gland,
16 - 63 A: IP 44 ▲
125 A: IP 67 ●²⁾

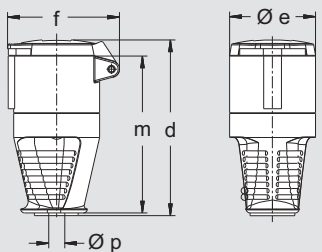

Amp.	16
Poles	5
d	121
Øe	51
f	68
m	108
Øp	8/15

Coupler
for light and stage engineering,
with inverted cable entry,
IP 44 ▲

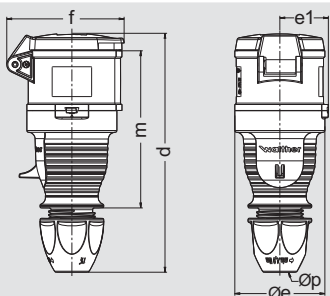

Amp.	16	32
Poles	5	5
d	165-176	189-199
Øe	65	72
e1	35	38,5
f	85	97
m	114	130
Øp	7,5/18,5	10-22,5

Coupler
for light and stage engineering,
with exterior cable gland,
IP 44 ▲

1) Drawing and dimensions for 125 A, IP 67 see chapter „Plugs“, part no. 279
2) Drawing and dimensions for 125 A, IP 67 see chapter „Couplers“, part no. 379



Ampère	Poles	110 V 50 a. 60 Hz			230 V 50 a. 60 Hz			400 V 50 a. 60 Hz			500 V 50 a. 60 Hz			Part numbers
		3pole 4h	4pole 4h	5pole 4h	3pole 6h	4pole 9h	5pole 9h	3pole 9h	4pole 6h	5pole 6h	3pole 7h	4pole 7h	5pole 7h	
16	3				211 306 SW								10	
16	4							211 406 SW					10	
16	5							211 SW					10	
32	3				231 306 SW								10	
32	4							231 406 SW					10	
32	5							231 SW					10	
63	3				261 306 SW								5	
63	4							261 406 SW					5	
63	5							261 SW					5	
125	3				279 306 SW ¹⁾								2	
125	4							279 406 SW ¹⁾					2	
125	5							279 SW ¹⁾					2	
16	3	215 304 SW			215 306 SW								10	
16	5							210 SW					10/60	
32	5							230 SW					10/60	
16	3				311 306 SW								10	
16	4							311 406 SW					10	
16	5							311 SW					10	
32	3				331 306 SW								10	
32	4							331 406 SW					10	
32	5							331 SW					10	
63	3				361 306 SW								5	
63	4							361 406 SW					5	
63	5							361 SW					5	
125	3				379 306 SW ²⁾								2	
125	4							379 406 SW ²⁾					2	
125	5							379 SW ²⁾					2	
16	3	315 304 SW			315 306 SW								10	
16	5							310 SW					10/60	
32	5							330 SW					10/60	



The here listed 63 A + 125 A panel sockets are also available with **pilot contact**.
To order them, simply add a „P“ behind the part number.

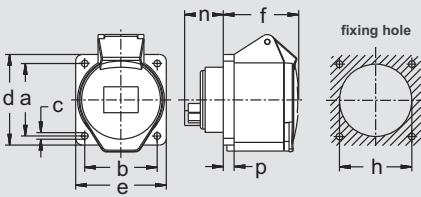

Amp.	16			32			63		
Poles	3	4	5	3	4	5	3	4	5
a	60	60	60	60	60	60	85	85	85
b	60	60	60	60	60	60	77	77	77
c	5,5	5,5	5,5	5,5	5,5	5,5	6,5	6,5	6,5
d	75	75	75	75	75	75	107	107	107
e	75	75	75	75	75	75	100	100	100
f	52	53	53	65	65	65	85	85	85
h	46	60	60	60	60	60	90	90	90
n	28	28	28	27	27	27	52	52	52
p	6	9	9	9	9	9	12	12	12

Panel sockets, straight,
for light and stage engineering,
16 - 63 A: IP 44, flange dimensions 75 x 75,
fingerproof acc. to BGV A3

63 A: IP 44, flange dimensions 107 x 100,
fingerproof acc. to BGV A3

125 A: IP 67³⁾

Female insert 710 116 / 710 116 01

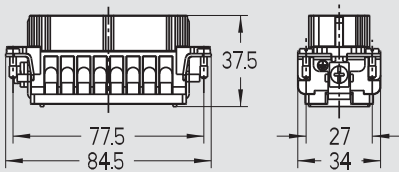

Male insert 710 216 / 710 216 01

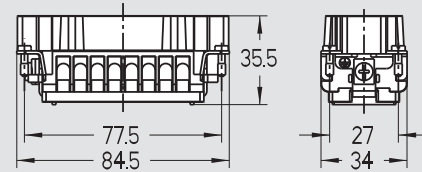

Female insert, screw terminals, wire protection, series B16, 0,5-2,5 mm² (20-14 AWG)

Female insert, insulation displacement connection, series B16, 0,5-2,5 mm² (20-14 AWG)

Male insert, screw terminals, wire protection, series B 16, 0,5-2,5 mm² (20-14 AWG)

Male insert, insulation displacement connection, series B16, 0,5-2,5 mm² (20-14 AWG)

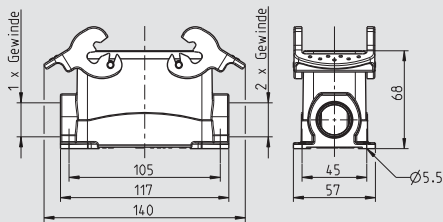

Wall mount housings
for light and stage engineering,
series B 16,
height 68 mm,
with double locking levers,
with collar,
without cable gland

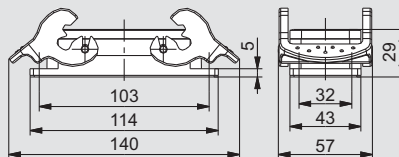

Panel housing
for light and stage engineering,
series B 16,
height 29 mm,
with double locking levers,
with recess for labels (clips),
panel cut-out 86 x 35 mm

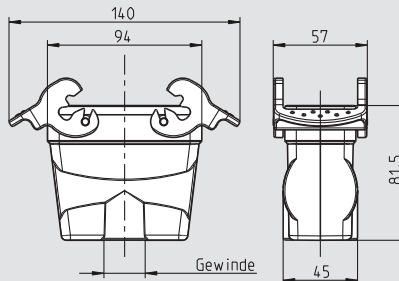

Coupler hoods
for light and stage engineering,
series B 16,
height 70,5 mm,
with double locking levers,
with collar,
without cable gland

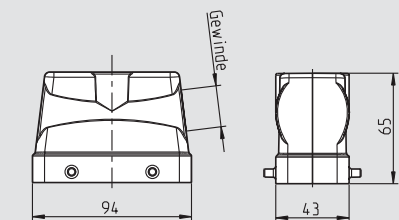

Hoods
for light and stage engineering,
series B 16,
height 60 mm,
for double locking levers,
side cable entry,
without cable gland, 1 x M 25

3) Drawing and dimensions for 125 A, IP 67 see chapter „Panel Sockets“, part no. 479

Ampère	Poles	110 V 50 a. 60 Hz			230 V 50 a. 60 Hz			400 V 50 a. 60 Hz			Accessories
		3pole 4h	4pole 4h	5pole 4h	3pole 6h	4pole 9h	5pole 9h	3pole 9h	4pole 6h	5pole 6h	



Also available as 6, 10 and 24 pole versions

		Part numbers					
16	3	410 304 SW	410 306 SW			10	
16	4			410 406 SW		10	
16	5			410 SW		10	
32	3			430 306 SW		10	
32	4				430 406 SW	10	
32	5				430 SW	10	
63	3			460 306 SW		5	
63	4				460 406 SW	5	
63	5				460 SW	5	
125	3			479 306 SW ⁽³⁾		2	
125	4				479 406 SW ⁽³⁾	2	
125	5				479 SW ⁽³⁾	2	
16		Female, screw terminals	710 116			10	
16		Female, IDC	710 116 01			10	
16		Male, screw terminals	710 216			10	
16		Male, IDC	710 216 01			10	
16			P711016MSSW	M 25 719 630		10	
16			P757072MSSW	M 32 719 631		10	
16			714 116 SW			10	
16			P 713 616 SW	M 25 719 630		10	
16			P 753 772 SW	M 32 719 631		10	
16			P 718 016 SW	M 25 719 630		10	
16			P 728 140 SW	M 32 719 631		10	



The here listed 63 A + 125 A panel sockets are also available with **pilot contact**. To order them, simply add a „P“ behind the part number.

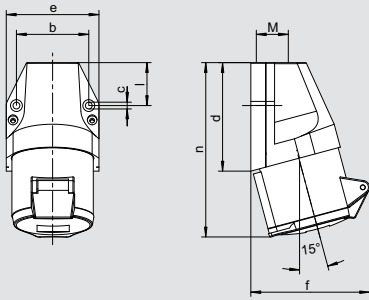

Amp.	16	32
Poles	7	7
b	60	60
c	5,3	5,3
d	80	97
e	74	82
f	90	105
l	31	45
n	129	155
M	20	25

Wall sockets,
external fixing,
1 top cable entry,
IP 44 ⚠

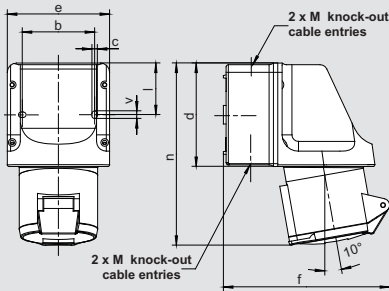

Amp.	16	32
Poles	7	7
b	66,5	66,5
c	5	5
d	96	96
e	95	95
f	146	157
l	47,5	47,5
n	164	173
v	7	7
M	20/25	20/25

Wall sockets,
internal fixing,
2 knock-out cable entries on top and bottom,
IP 44 ⚠

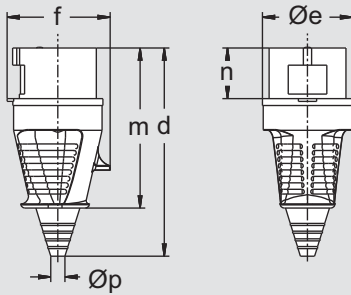

Amp.	16	32
Poles	7	7
d	153	181
Øe	65	72
f	75	88
m	117	138
n	37	46
Øp	8/21	11/24

Plugs,
flexible cable entry,
IP 44 ⚠

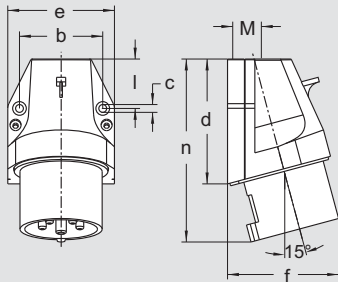

Amp.	16	32
Poles	7	7
b	60	60
c	5,3	5,3
d	80	97
e	74	82
f	73	86
l	31	45
n	117	141
M	20	25

Wall mount appliance inlets,
external fixing,
1 top cable entry,
IP 44 ⚠

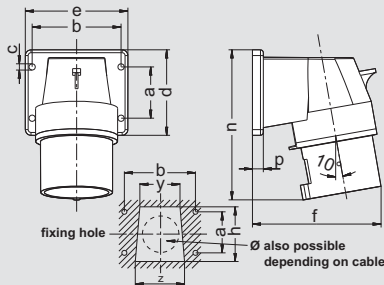

Amp.	16	32
Poles	7	7
a	40	45
b	68	78
c	5,5	5,5
d	66	75
e	80	90
f	92	103
h	52	60
n	110	129
p	9,5	9,5
y	38	44
z	46	54

Panel mount appliance inlets, angled,
screwed flange enclosure,
IP 44 ⚠

Fixing dimensions = a + b,
Flange dimensions = d + e

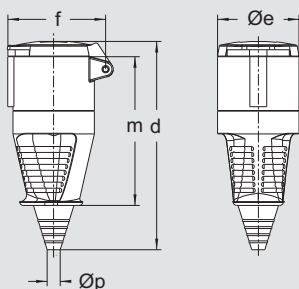





Amp.	16	32
Poles	7	7
d	167	196
Øe	65	72
f	85	98
m	119	141
Øp	8/21	11/24

Couplers,
flexible cable entry,
IP 44 ⚠

7-pole plugs & sockets

Ampère	Poles	230 V 50 a. 60 Hz			400 V 50 a. 60 Hz			500 V 50 a. 60 Hz			
		3pole 6h	4pole 9h	5pole 9h	3pole 9h	4pole 6h	5pole 6h	3pole 7h	4pole 7h	5pole 7h	



		Part numbers									
16	7	110 709	110 706	110 707	10						
	32	130 709	130 706	130 707	10						
16	7	111 709	111 706	111 707	5						
	32	131 709	131 706	131 707	5						
16	7	210 709	210 706	210 707	10						
	32	230 709	230 706	230 707	10						
16	7	610 709	610 706	610 707	10						
	32	630 709	630 706	630 707	10						
16	7	611 709	611 706	611 707	10						
	32	631 709	631 706	631 707	10						
16	7	310 709	310 706	310 707	10						
	32	330 709	330 706	330 707	10						

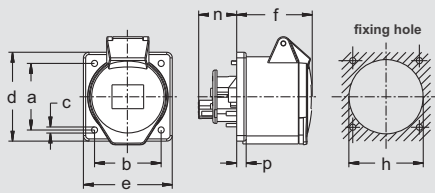

Amp.	16	32
Poles	7	7
a	60	60
b	60	60
c	5,5	5,5
d	80	80
e	80	80
f	60	60
h	67	71
n	23,5	23,5
p	8,5	8,5

Fixing dimensions = a + b,
Flange dimensions = d + e

Panel sockets, straight,
screwed flange,
flange dimensions 80 x 80,
IP 44 ⚠

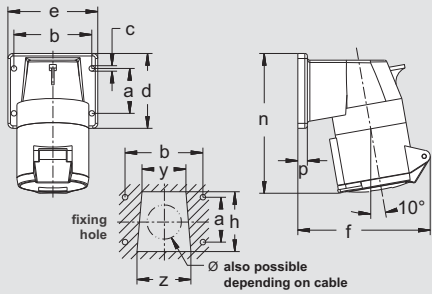

Amp.	16	32
Poles	7	7
a	40	45
b	68	78
c	5,5	5,5
d	66	75
e	80	90
f	110	124
h	52	60
n	122	142
p	9,5	9,5
y	38	44
z	46	54

Fixing dimensions = a + b,
Flange dimensions = d + e

Panel sockets, angled,
screwed flange enclosure,
IP 44 ⚠

7-pole plugs & sockets

Ampère	Poles	230 V 50 a. 60 Hz			400 V 50 a. 60 Hz			500 V 50 a. 60 Hz				 6 P + E
		3pole 6h	4pole 9h	5pole 9h	3pole 9h	4pole 6h	5pole 6h	3pole 7h	4pole 7h	5pole 7h		

		Part numbers								
16	7	411 709	411 706	411 707	10					
	32	431 709	431 706	431 707	10					
16	7	514 709	514 706	514 707	10					
	32	534 709	534 706	534 707	10					



9

7-pole plugs and sockets

always come with nickel-plated contacts - **for protection against oxidation.**

If an electrical drive is operated via a plug and socket device, e.g. star-delta starting, Dalander connection or conveyor belt systems, then 7-pole plugs and sockets have to be used.

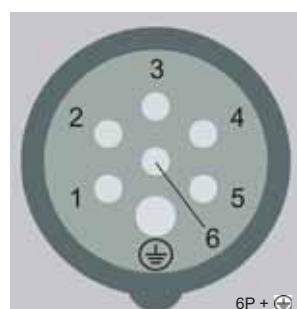

Plastic socket combinations, wall mount,
enclosures 657/658/659

Cable entry 2 x on top and bottom M 20/25, knock-out

657

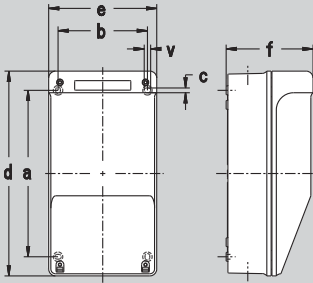

a	b	c	d	e	f	v	M
192	103	5,5	237	125	100,5	7,5	20/25

658

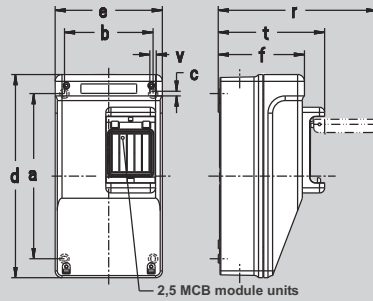

a	b	c	d	e	f	r	t	v	M
192	103	5,5	237	125	100,5	185	124	7,5	20/25

659

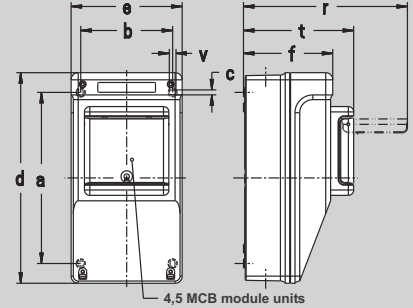

a	b	c	d	e	f	r	t	v	M
192	103	5,5	237	125	100,5	185	124	7,5	20/25

10



657 01 05



658 01 05

stock item



659 00 01

stock item

Plastic enclosure, wall mount, wired ready for connection

Part no.	CEE panel sockets 5-pole 400 V				3-pole 230 V 16 A	Schuko 16 A	Protection Neozed	Protection MCB	RCD	IP degree	
	125 A	63 A	32 A	16 A						IP 44	IP 67
657 01 05				1		2				I	
658 01 05				1		1		1 x B16/1-pole		I	
659 00 01						2		2 x B16/1-pole	2/25/0,03 A	I	
659 00 06						2		2 x C16/1-pole	2/25/0,03 A	I	



Plastic enclosure, wall mount, wired ready for connection

Part no.	CEE panel sockets 5-pole 400 V				3-pole 230 V 16 A	Schuko 16 A	Neozed	Protection		IP degree	
	125 A	63 A	32 A	16 A				MCB	RCD	IP 44	IP 67
657 01 06 X7				1		1					I
658 11 03			1			1		1 x B16/1-pole		I	
659 11 05 X7			1						4/40/0,03 A		I
659 01 05				1				1 x C16/3-pole		I	
659 01 04				1					4/40/0,03 A	I	
659 01 07				1					RCBO 4/16/0,03 AC	I	

Plastic socket combinations, wall mount,
enclosures 691/692

Cable entry 2 x on top and bottom M 25 / M 32 / M 40, knock-out

691

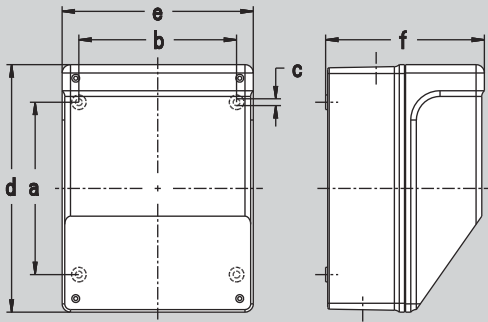

a	b	c	d	e	f	M
165	151	6,5	237	183	152	25/32/40

692

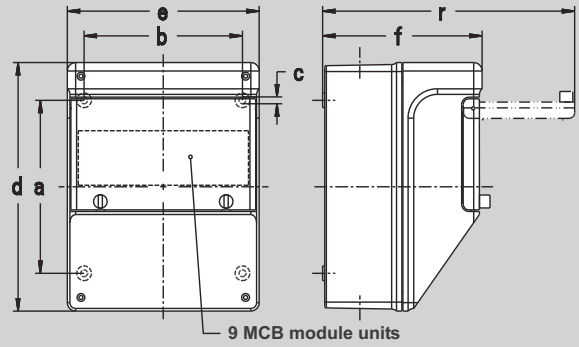

a	b	c	d	e	f	r	M
165	151	6,5	237	183	152	241	25/32/40



Plastic enclosure, wall mount, wired ready for connection

Part no.	CEE panel sockets 5-pole 400 V				3-pole 230 V 16 A	Schuko 16 A	Protection			IP degree	
	125 A	63 A	32 A	16 A			Neozed	MCB	RCD	IP 44	IP 67
691 00 04						6				I	
691 02 01				2		2				I	
691 30 01			1	1		3				I	



Plastic enclosure, wall mount, wired ready for connection

Part no.	CEE panel sockets 5-pole 400 V				3-pole 230 V 16 A	Schuko 16 A	Neozed	Protection		IP degree	
	125 A	63 A	32 A	16 A				MCB	RCD	IP 44	IP 67
692 01 32				1		1		1 x C16/3-pole 1 x B16/1-pole	4/40/0,03 A	I	
692 01 08				1		2		1 x C16/3-pole 2 x B16/1-pole		I	
692 01 30				1		2		1 x C16/3-pole 2 x B16/1-pole	4/40/0,03 A	I	
692 01 17				1		2		1 x C16/3-pole 2 x C16/1-pole	4/40/0,03 A	I	
692 02 07				2				2 x C16/3-pole	4/40/0,03 A	I	
692 11 17			1			1		1 x C32/3-pole 1 x C16/1-pole	4/40/0,03 A	I	
692 12 02			2					2 x C32/3-pole		I	

Plastic socket combinations, wall mount, enclosure 698

Cable entry 2 x on top and bottom M 25 / M 32 / M 40, knock-out

698

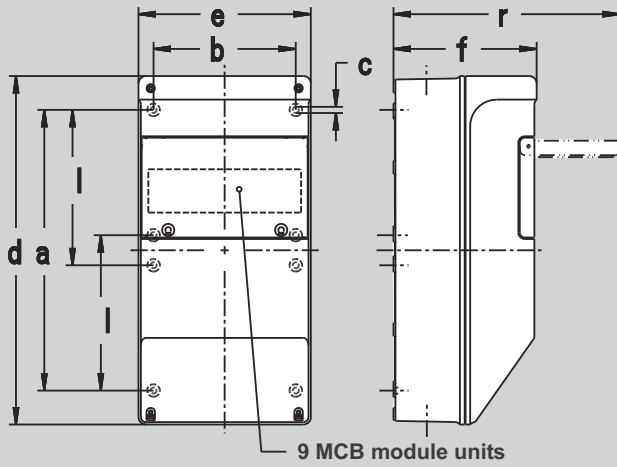

a	b	c	d	e	f	l	r	M
298	151	6,5	370	183	152	165	240	25/32/40



10

Plastic enclosure, wall mount, wired ready for connection

Part no.	CEE panel sockets 5-pole 400 V				3-pole 230 V 16 A	Schuko 16 A	Neozed	Protection		Terminal block K25	IP degree	
	125 A	63 A	32 A	16 A				MCB	RCD		IP 44	IP 67
698 00 03						6		6 x C16/1-pole	4/40/0,03 A	5-pole	I	
698 01 07				1		3		1 x C16/3-pole 3 x B16/1-pole	4/40/0,03 A	5-pole	I	
698 02 02				2		3		2 x C16/3-pole 3 x B16/1-pole		5-pole	I	
698 11 01			1			4		1 x C32/3-pole 2 x B16/1-pole	4/40/0,03 A	10-pole	I	



Plastic enclosure, wall mount, wired ready for connection

Part no.	CEE panel sockets 5-pole 400 V				3-pole 230 V 16 A	Schuko 16 A	Neozed	Protection		Terminal block K25	IP degree	
	125 A	63 A	32 A	16 A				MCB	RCD		IP 44	IP 67
698 12 03			2			3		2 x C32/3-pole 3 x B16/1-pole		5-pole	I	
698 30 03			1	1		2		1 x C32/3-pole 1 x C16/3-pole 2 x B16/1-pole		5-pole	I	
698 30 11			1	1		2		1 x C16/3-pole 2 x B16/1-pole	4/40/0,03 A	5-pole	I	
698 30 01			1	1		3		1 x C32/3-pole 1 x C16/3-pole 3 x C16/1-pole		5-pole	I	
698 30 17			1	1		3		1 x C16/3-pole 3 x C16/1-pole	4/40/0,03 A	5-pole	I	
698 21 11		1						1 x C63/3-pole	4/63/0,03 A	10-pole	I	

Plastic socket combinations, wall mount,
enclosure 699

Cable entry 2 x on top and bottom M 25 / M 32 / M 40, knock-out

699

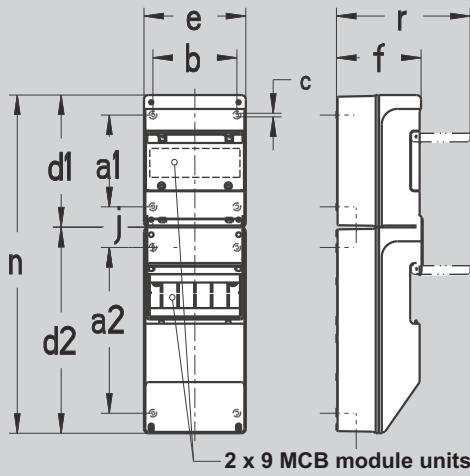

a1	a2	b	c	d1	d2	e	f	j	n	r	M
165	298	151	6,5	237	370	183	152	73	608	241	25/32/40



Plastic enclosure, wall mount, wired ready for connection

Part no.	CEE panel sockets 5-pole 400 V				3-pole 230 V 16 A	Schuko 16 A	Neozed	Protection		Terminal block K25	IP degree	
	125 A	63 A	32 A	16 A				MCB	RCD		IP 44	IP 67
699 03 01				3		2		3 x C16/3-pole 2 x B16/1-pole	4/63/0,03 A	10-pole	I	
699 12 03			2			3		2 x C32/3-pole 3 x C16/1-pole	4/63/0,03 A	10-pole	I	
699 30 09			1	1		2		1 x C32/3-pole 1 x C16/3-pole 2 x B16/1-pole	4/40/0,03 A	10-pole	I	
699 31 02			1	2		2		1 x C32/3-pole 2 x C16/3-pole 2 x B16/1-pole	4/63/0,03 A	10-pole	I	

Plastic socket combinations, wall mount, enclosure 685

Cable entry 3 x on top and bottom M 40 / M 50, knock-out

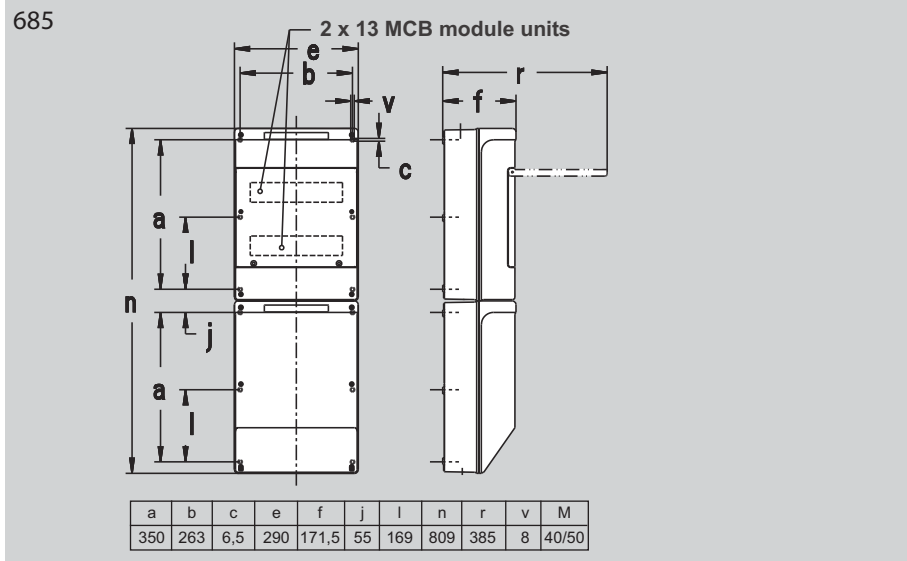

Plastic enclosure, wall mount, wired ready for connection

Part no.	CEE panel sockets 5-pole 400 V				3-pole 230 V 16 A	Schuko 16 A	Neozed	Protection		Terminal block	IP degree	
	125 A	63 A	32 A	16 A				MCB	RCD		IP 44	IP 67
685 34 01			3	3		3		3 x C32/3-pole 3 x C16/3-pole 3 x B16/1-pole	4/40/0,03 A only for Schuko	K 35 5-pole	I	
685 44 01		1	1	1		3		1 x C63/3-pole 1 x C32/3-pole 1 x C16/3-pole 3 x B16/1-pole	2 x 4/63/0,03 A 1 x main switch 3/125 A	K 35 5-pole	I	
685 47 01		1	2	2		3		1 x C63/3-pole 2 x C32/3-pole 2 x C16/3-pole 3 x B16/1-pole	4/40/0,03 A only for Schuko	K 35 5-pole	I	
685 91 AC	1	1	1	1		4		1 x C63/3-pole 1 x C32/3-pole 1 x C16/3-pole 4 x B16/1-pole	4/125/0,03 A	K 50 5-pole	I	

Plastic socket combinations, wall mount, enclosure 682

Cable entry 3 x on top and bottom M 40 / M 50, knock-out

682

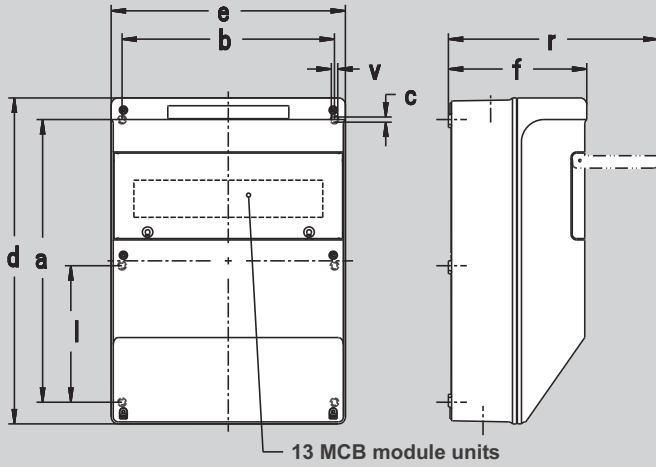

a	b	c	d	e	f	l	r	v	M
350	263	6,5	404	290	171,5	169	260	8	40/50



682 02 02X7



682 03 01



682 12 06



682 30 02

Plastic enclosure, wall mount, wired ready for connection

Part no.	CEE panel sockets 5-pole 400 V				3-pole 230 V 16 A	Schuko 16 A	Neozed	Protection		Terminal block K25	IP degree	
	125 A	63 A	32 A	16 A				MCB	RCD		IP 44	IP 67
682 02 02 X7				2		3		2 x C16/3-pole 3 x C16/1-pole	4/63/0,03 A	10-pole		I
682 03 01				3		4		3 x C16/3-pole 4 x B16/1-pole		5-pole	I	
682 12 06			2			3		2 x C32/3-pole 3 x B16/1-pole	4/63/0,03 A	10-pole	I	
682 30 02			1	1		3		1 x C32/3-pole 1 x C16/3-pole 3 x B16/1-pole	4/63/0,03 A	10-pole		I



Plastic enclosure, wall mount, wired ready for connection

Part no.	CEE panel sockets 5-pole 400 V				3-pole 230 V 16 A	Schuko 16 A	Neozed	Protection MCB	RCD	Terminal block K25	IP degree	
	125 A	63 A	32 A	16 A							IP 44	IP 67
682 30 08			1	1		3		1 x C32/3-pole 1 x C16/3-pole 3 x B16/1-pole	4/40/0,03 A	10-pole	I	
682 30 01			1	1		4		1 x C32/3-pole 1 x C16/3-pole 4 x B16/1-pole	4/40/0,03 A	10-pole	I	
682 33 01			2	2		2		2 x C32/3-pole 2 x C16/3-pole 1 x B16/1-pole		5-pole	I	
682 44 02		1	1	1		2		1 x C32/3-pole 1 x C16/3-pole 2 x B16/1-pole	4/63/0,03 A	10-pole	I	
682 44 03 X7		1	1	1		2		1 x C32/3-pole 1 x C16/3-pole 2 x C16/1-pole	4/63/0,03 A	10-pole		I
682 44 17		1	1	1		3		1 x C32/3-pole 1 x C16/3-pole 3 x B16/1-pole	4/63/0,03 A	10-pole	I	

Other socket combination versions acc. to your requirements available on request

Plastic socket combinations, wall mount,
enclosure 689

Cable entry 3 x on top and bottom M 40 / M 50, knock-out

689

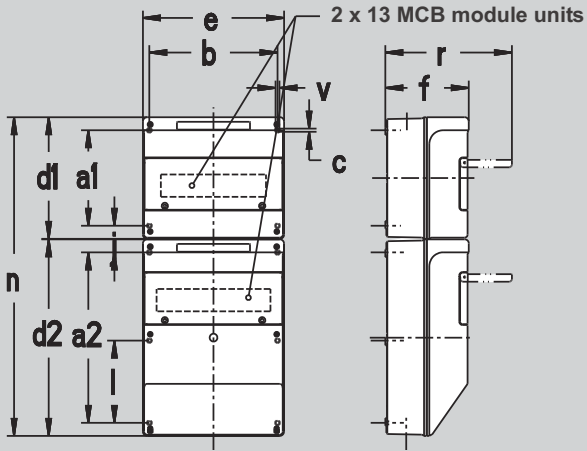

a1	a2	b	c	d1	d2	e	f	j	n	r	l	v	M
196	350	263	6,5	250	404	290	171,5	55	655	260	169	8	40/50



689 03 01



689 04 01



689 30 06



689 31 02

Plastic enclosure, wall mount, wired ready for connection

Part no.	CEE panel sockets 5-pole 400 V				3-pole 230 V 16 A	Schuko 16 A	Neozed	Protection		Terminal block K25	IP degree	
	125 A	63 A	32 A	16 A				MCB	RCD		IP 44	IP 67
689 03 01				3		4		3 x C16/3-pole 4 x B16/1-pole	4/63/0,03 A	10-pole	I	
689 04 01				4		2		4 x C16/3-pole 2 x B16/1-pole	4/63/0,03 A	10-pole	I	
689 30 06			1	1		6		1 x C32/3-pole 1 x C16/3-pole 6 x C16/1-pole	4/63/0,03 A	10-pole	I	
689 31 02			1	2		4		1 x C32/3-pole 2 x C16/3-pole 4 x B16/1-pole	4/63/0,03 A	10-pole	I	



Plastic enclosure, wall mount, wired ready for connection

Part no.	CEE panel sockets 5-pole 400 V				3-pole 230 V 16 A	Schuko 16 A	Protection Neozed	Protection MCB	RCD	Terminal block K25	IP degree	
	125 A	63 A	32 A	16 A							IP 44	IP 67
689 32 01			2	1		4		2x C32/3-pole 1x C16/3-pole 4x B16/1-pole	4/63/0,03 A	10-pole	I	
689 33 01			2	2		2		2x C32/3-pole 2x C16/3-pole 2x B16/1-pole	4/63/0,03 A	10-pole	I	
689 34 01			2	3		2		2x C32/3-pole 3x C16/3-pole 2x B16/1-pole	4/63/0,03 A	10-pole	I	
689 35 01			1	1	1	3	1xD02/3-pole 1xD01/3-pole 4xD01/1-pole		4/63/0,03 A	10-pole	I	
689 44 05		1	1	1		2	2xD02/3-pole 1xD01/3-pole 2xD01/1-pole		4/63/0,03 A	10-pole	I	
689 44 09		1	1	1		2	1xD02/3-pole	1x C32/3-pole 1x C16/3-pole 2x B16/1-pole	4/63/0,03 A	10-pole	I	

PBT plastic socket combinations, chemical resistant

For areas where chemicals and aggressive media are used, the use of enclosures made of PBT plastic is recommended.

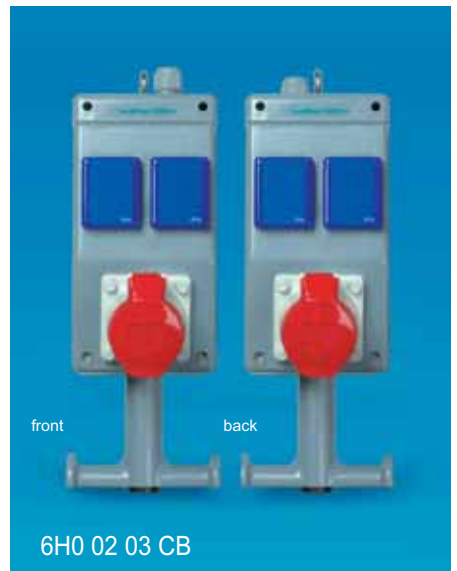

10

PBT plastic enclosure, chemical resistant, wired ready for use. Further enclosure sizes on request.

Part no.	CEE panel sockets 5-pole 400 V				3-pole 230 V 16 A	Schuko 16 A	Neozed	Protection		Terminal block	IP degree	
	125 A	63 A	32 A	16 A				MCB	RCD		IP 44	IP 67
657 01 06 X7CB				1		1				K6 5-pole		I
692 01 30 CB				1		2		1 x C16/3-pole 2 x B16/1-pole	4/40/0,03 A	K25 5-pole	I	
698 30 11 CB			1	1		2		1 x C16/3-pole 2 x B16/1-pole	4/40/0,03 A	K25 5-pole	I	
682 30 06 CB			1	1		2		1 x C32/3-pole 1 x C16/3-pole 2 x B16/1-pole	4/40/0,03 A	K25 10-pole	I	
682 30 06 X7 CB			1	1		2		1 x C32/3-pole 1 x C16/3-pole 2 x B16/1-pole	4/40/0,03 A	K25 10-pole		I
6H0 02 03 CB				2		4				K6 5-pole	I	

Solid rubber socket combinations, wall-mount, enclosure 644

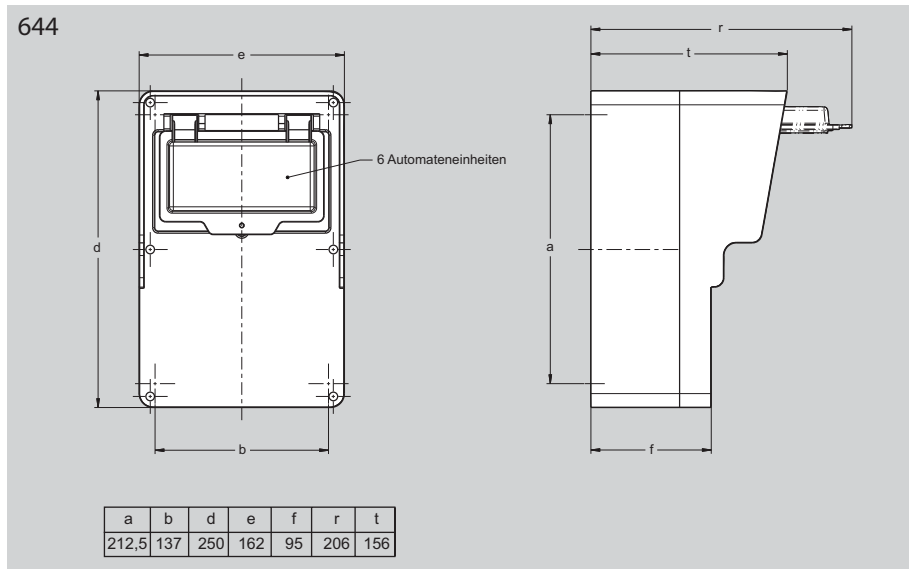

10

Plastic enclosure, wall mount, wired ready for connection

Part no.	CEE panel sockets 5-pole 400 V				3-pole 230 V 16 A	Schuko 16 A	Protection MCB	RCD	Terminal block	IP degree	
	125 A	63 A	32 A	16 A						IP 44	IP 67
644 11 L0			1							I	
644 00 02						2	2 x C16/1-pole	2/25/0,03 A	5-pole K16	I	
644 01 04				1			1 x C16/3-pole	4/40/0,03 A	5-pole K25	I	
644 11 01			1					4/40/0,03 A	5-pole K16	I	

Other socket combination versions acc. to your requirements available on request

Solid rubber socket combinations, wall mount, enclosure 645

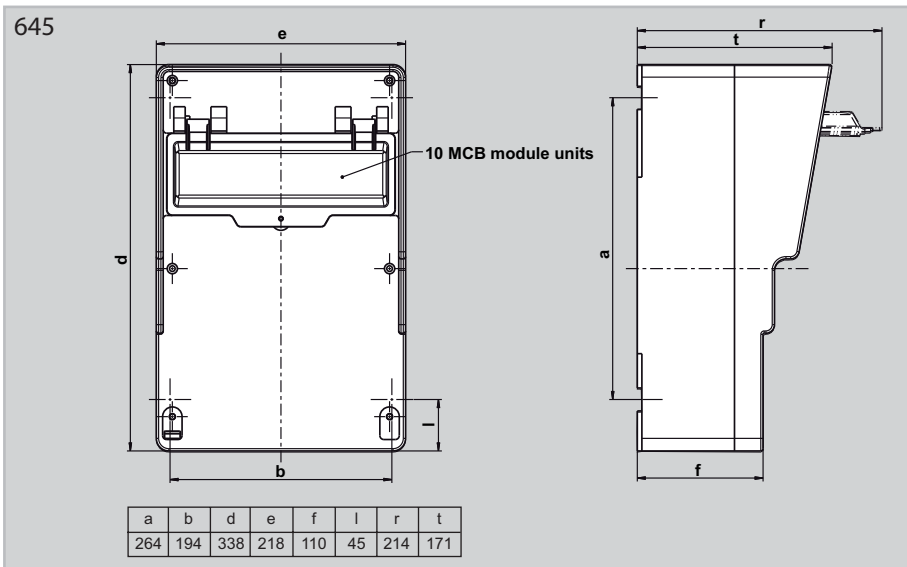

Solid rubber enclosure, wall mount, wired ready for connection

Part no.	CEE panel sockets 5-pole 400 V				3-pole 230 V 16 A	Schuko 16 A	Protection Neozed	Protection		Terminal block K25	IP degree	
	125 A	63 A	32 A	16 A				MCB	RCD		IP 44	IP 67
645 01 L2				1		2						
645 00 01						6		6 x B16/1-pole	4/40/0,03 A	5-pole	I	
645 01 01				1		2		1 x C16/3-pole 2 x B16/1-pole	4/40/0,03 A	5-pole	I	
645 11 01			1			2		1 x C32/3-pole 2 x B16/1-pole	4/40/0,03 A	5-pole	I	

Solid rubber socket combinations, wall-mount, enclosure 646

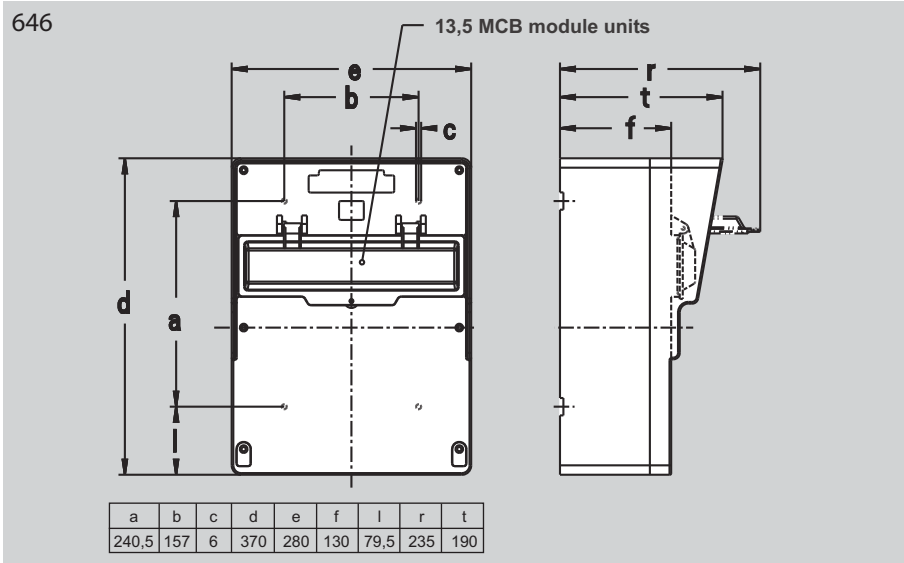

10

Solid rubber enclosure, wall mount, wired ready for connection

Part no.	CEE panel sockets 5-pole 400 V				3-pole 230 V 16 A	Schuko 16 A	Neozed	Protection		Terminal block K25	IP degree	
	125 A	63 A	32 A	16 A				MCB	RCD		IP 44	IP 67
646 02 05				2		3		2xC16/3-pole 3xB16/1-pole	4/40/0,03 A	10-pole	I	
646 30 03			1	1		3	1xD02/3-pole 1xD01/3-pole 3xD01/1-pole			5-pole	I	
646 30 01			1	1		3		1xC32/3-pole 1xC16/3-pole 3xB16/1-pole	4/63/0,03 A	10-pole	I	
646 12 01			2			3		2xC32/3-pole 3xC16/1-pole	4/63/0,03 A	10-pole	I	

Other socket combination versions acc. to your requirements available on request

Solid rubber socket combinations, wall mount, enclosure 647

647

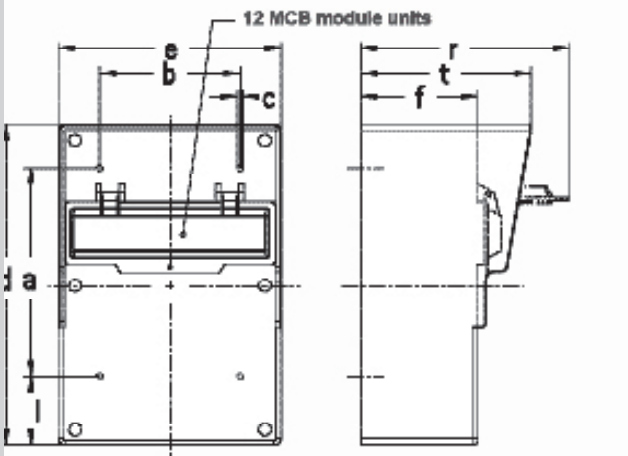

a	b	c	d	e	f	l	r	t
240,5	157	6,5	370	248	130	79,5	235	190



647 02 01



647 30 02

stock item



647 30 AL



647 21 01

10

Solid rubber enclosure, wall mount, wired ready for connection

Part no.	CEE panel sockets 5-pole 400 V				3-pole 230 V 16 A	Schuko 16 A	Neozed	Protection		Terminal block K25	IP degree	
	125 A	63 A	32 A	16 A				MCB	RCD		IP 44	IP 67
647 02 01				2		3		2 x C16/3-pole 3 x B16/1-pole	4/40/0,03 A	10-pole	I	
647 30 02			1	1		3		1 x C32/3-pole 1 x C16/3-pole 3 x B16/1-pole	4/40/0,03 A	10-pole	I	
647 30 AL			1	1		3	1 x D01/3-pole 3 x D01/1-pole		4/40/0,03 A	10-pole	I	
647 21 01		1				2	1 x D02/3-pole 2 x D01/1-pole		4/63/0,03 A	10-pole	I	

Solid rubber socket combinations, wall-mount, enclosure 648

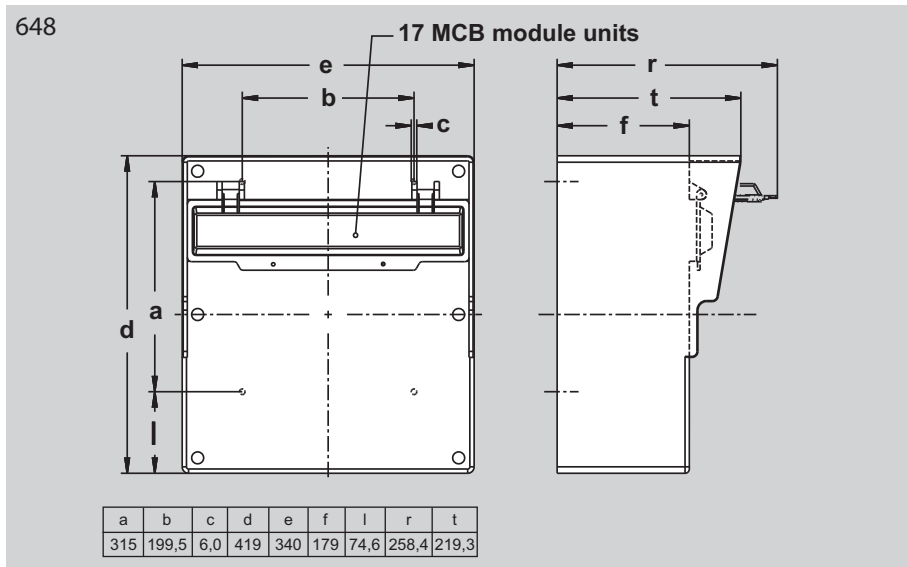

10

Solid rubber enclosure, wall mount, wired ready for connection

Part no.	CEE panel sockets 5-pole 400 V				3-pole 230 V 16 A	Schuko 16 A	Neozed	Protection MCB	RCD	Terminal block K25	IP degree	
	125 A	63 A	32 A	16 A							IP 44	IP 67
648 31 04			1	2		4		1xC32/3-pole 2xC16/3-pole 4xB16/1-pole	4/63/0,03 A	5-pole	I	
648 33 03			2	2		4		2xC32/3-pole 2xC16/3-pole 4xB16/1-pole		10-pole	I	
648 33 04			2	2		4		1xC32/3-pole 1xC16/3-pole 4xB16/1-pole	4/63/0,03 A	10-pole	I	
648 44 AE		1	1	1		2	1xD02/3-pole	1xC32/3-pole 1xC16/3-pole 2xB16/1-pole	4/63/0,03 A	10-pole	I	



Portable plastic distributors

Part no.	CEE panel sockets 5-pole 400 V				3-pole 230 V 16 A	Schuko 16 A	Supply 2 m supply line	Protection		P degree	
	125 A	63 A	32 A	16 A				MCB	RCD	IP 44	IP 67
692 00 07						4	H07RN-F5G6 CEE-plug 32 A	4 x B16/1-pole	4/40/0,03 A	I	
692 01 66				1		2	H07RN-F5G6 CEE-plug 32 A	1 x C16/1-pole 2 x B16/1-pole	4/40/0,03 A	I	
692 02 08				2			H07RN-F5G6 CEE-plug 32 A	2 x C16/3-pole	4/40/0,03 A	I	
698 00 04						6	H07RN-F5G6 CEE-plug 32 A	6 x B16/1-pole	4/40/0,03 A	I	
698 30 13			1	1		3	H07RN-F5G6 CEE-plug 32 A	1 x C16/3-pole 3 x B16/1-pole	4/40/0,03 A	I	
682 02 21				2		4	H07RN-F5G6 CEE-plug 32 A	2 x C16/3-pole 4 x B16/1-pole	4/40/0,03 A	I	
600 KG 01 for 698 and 682 enclosure series											

Solid rubber socket combinations, portable, enclosures 643 / 649 / 649/2

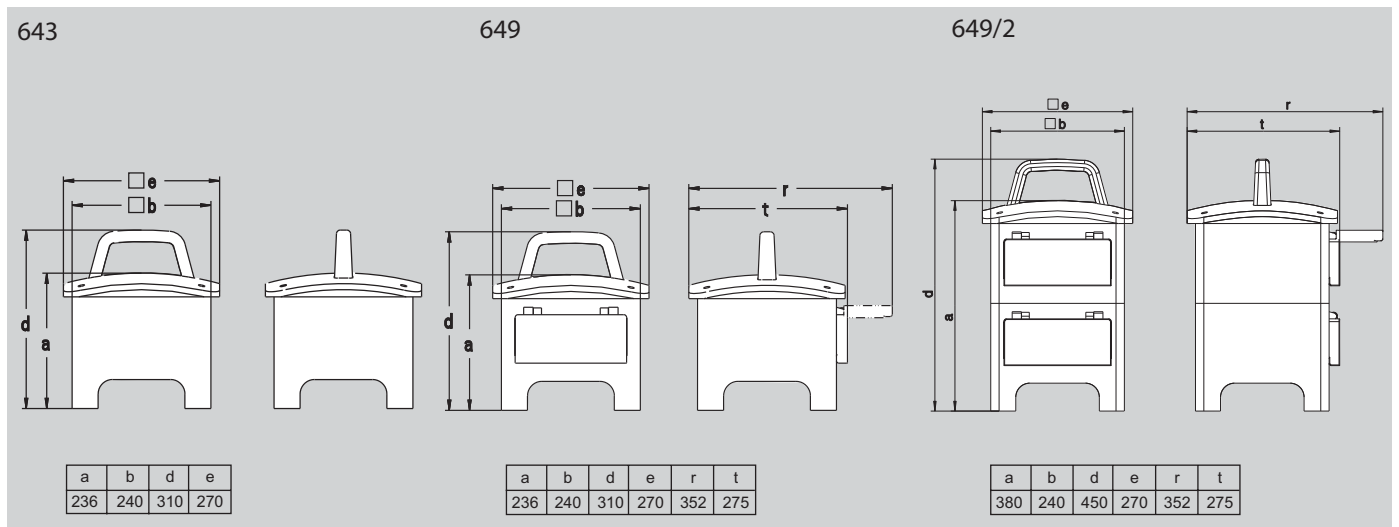

Portable solid rubber distributors

Schuko sockets IP 54 acc. to DIN VDE 0620-1

Part no.	CEE panel sockets 5-pole 400 V				Schuko 16 A	Supply 2 m supply line	Panel mount appliance inlet	Protection		IP degree	
	125 A	63 A	32 A	16 A				MCB	RCD	IP 44	IP 67
643 02 09 A				2	4		16 A			I	
643 02 03 A				2	4	H07RN-F5G2,5 CEE-plug 16 A				I	
649 00 19 A					6		16 A		4/40/0,03 A	I	

Other socket combination versions acc. to your requirements available on request

Solid rubber socket combinations, portable, enclosure 649



Portable solid rubber distributors

Schuko sockets IP 54 acc. to DIN VDE 0620-1

Part no.	CEE panel sockets 5-pole 400 V				Schuko 16 A	Supply 2 m supply line	Panel mount appliance inlet	Protection		IP degree	
	125 A	63 A	32 A	16 A				MCB	RCD	IP 44	IP 67
649 00 16 A					6	H07RN-F5G 2,5 CEE-plug 16 A			4/40/0,03 A	I	
649 00 06 A					8		16 A		4/40/0,03 A	I	
649 00 01 A					8	H07RN-F5G 2,5 CEE-plug 16 A			4/40/0,03 A	I	
649 02 10 A				2	4		16 A		4/40/0,03 A	I	
649 02 09 A				2	4	H07RN-F5G 2,5 CEE-plug 16 A			4/40/0,03 A	I	
649 02 03 A				2	4		32 A	1 x C16/3-pole 2 x B16/1-pole	4/40/0,03 A	I	

Solid rubber socket combinations, portable, enclosure 649 / 649/2



Portable solid rubber distributors

Schuko sockets IP 54 acc. to DIN VDE 0620-1

Part no.	CEE panel sockets 5-pole 400 V				Schuko 16 A	Supply 2 m supply line	Panel mount appliance inlet	Protection		IP degree	
	125 A	63 A	32 A	16 A				MCB	RCD	IP 44	IP 67
649 31 09 A			1	2	4	H07RN-F5G 6 CEE-plug 32 A		1 x C16/3-pole 2 x C16/1-pole	4/40/0,03 A	I	
649 33 15 A			2	2	2	H07RN-F5G 6 CEE-plug 32 A		2 x C16/3-pole 1 x B16/1-pole	4/40/0,03 A	I	
649 33 03 A			2	2	8		63 A	2 x C32/3-pole 2 x C16/3-pole 4 x B16/1-pole	4/63/0,03 A	I	
649 33 04 B			2	2	8	H07RN-F5G 16 CEE-plug 63 A		2 x C32/3-pole 2 x C16/3-pole 4 x B16/1-pole	4/63/0,03 A	I	
649 54 03 A		1	2	2	4		63 A	2 x C32/3-pole 2 x C16/3-pole 4 x B16/1-pole	4/63/0,03 A	I	
649 54 04 B		1	2	2	4	H07RN-F5G 16 CEE-plug 63 A		2 x C32/3-pole 2 x C16/3-pole 4 x B16/1-pole	4/63/0,03 A	I	

Other socket combination versions acc. to your requirements available on request

Power strips, plastic, with handle,
enclosure 650/651

Cable entry 1 x M 20 / M 25, knock-out

650

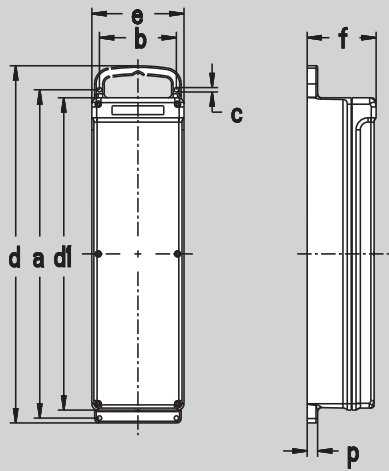

a	b	c	d	d1	e	f	p
410	96	5,5	446	390	115	86	13



10

Power strips, plastic

Part no.	CEE panel sockets 5-pole 400 V				3-pole 230 V 16 A	Schuko 16 A	Supply 2 m supply line	Protection		Terminal block K 6	IP degree	
	125 A	63 A	32 A	16 A				MCB	RCD		IP 44	IP 67
650 00 03						6				5-pole	I	
650 03 01				3		2				5-pole	I	
651 00 01						4			4/40/0,03 A	5-pole	I	
651 01 01				1		3			4/40/0,03 A	5-pole	I	

Power strips, solid rubber, with handle,
enclosure 640

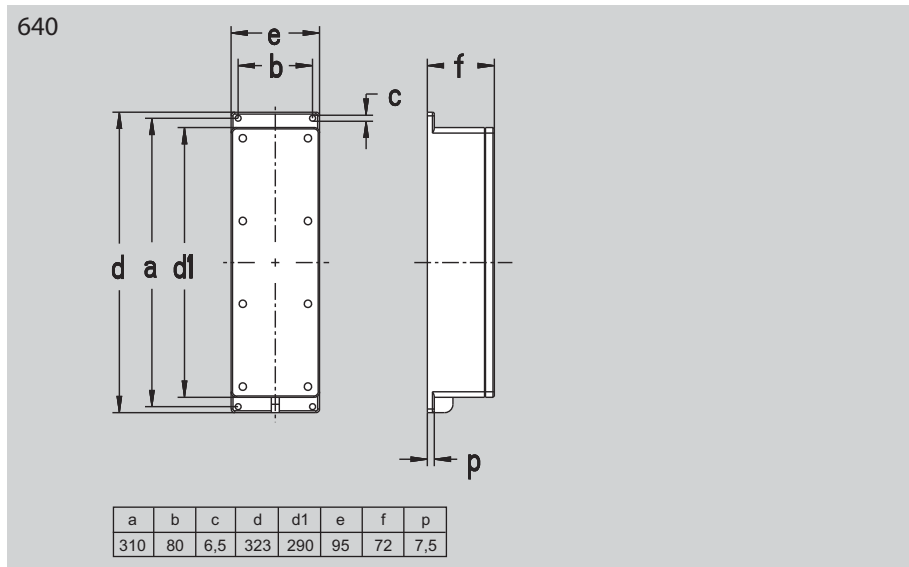

10

Power strips, solid rubber

Schuko sockets IP 54 acc. to DIN VDE 0620-1

Part no.	CEE panel sockets 5-pole 400 V				3-pole 230 V 16 A	Schuko 16 A	Supply 2 m supply line	Protection		IP degree	
	125 A	63 A	32 A	16 A				MCB	RCD	IP 44	IP 67
640 00 10 A						4	H07RN-F3G 2,5 Schuko-plug				I
640 00 04 A						3	H07RN-F3G 2,5 Schuko-plug		2/25/0,03 A		I
640 00 11 A						4	H07RN-F3G 2,5 Schuko-plug	PRCD - S 3-pole 16/0,03 A			I
640 01 01 A				1		2	H07RN-F5G 2,5 CEE-plug 16 A				I

Other socket combination versions acc. to your requirements available on request

Power strips, solid rubber, with handle,
enclosure 641

641

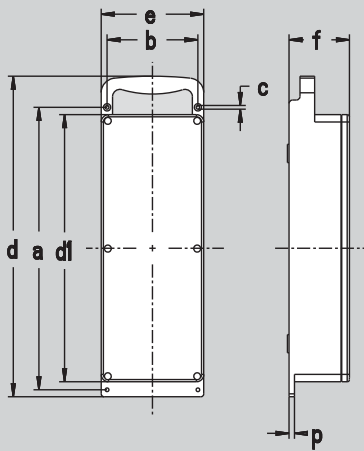

a	b	c	d	d1	e	f	p
418,3	135,6	5,7	462	398	150,4	90,5	16,5



Power strip, solid rubber

Schuko sockets IP 54 acc. to DIN VDE 0620-1

Part no.	CEE panel sockets 5-pole 400 V				3-pole 230 V 16 A	Schuko 16 A	Supply 2 m supply line	Protection		IP degree	
	125 A	63 A	32 A	16 A				MCB	RCD	IP 44	IP 67
641 00 02 A						4	H07RN-F5G 2,5 CEE-plug 16 A		4/40/0,03 A	I	
641 01 01 A				1		4	H07RN-F5G 2,5 CEE-plug 16 A			I	
641 01 02 A				1		2	H07RN-F5G 2,5 CEE-plug 16 A		4/40/0,03 A	I	
641 02 01				2			H07RN-F5G 6 CEE-plug 32 A	2 x C 16/3-pole		I	

Suspension-type socket combinations, plastic, enclosures 6H0, 6H1, 6H

6H0

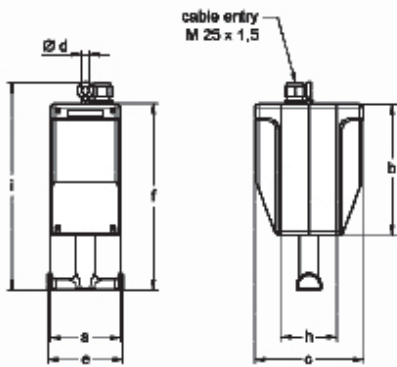

a	b	c	ød	e	f	i	h
126	237	195	12	136	337	374	100

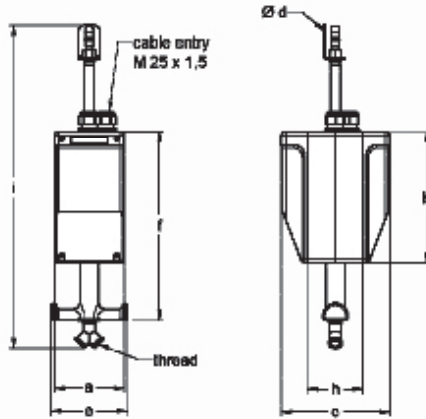

a	b	c	ød	e	f	i	h	thread
126	237	195	10	136	337	ca. 600	100	G3/8"



10

Suspension-type combination, plastic enclosure, wired ready for connection

Part no.	CEE panel sockets 5-pole 400 V				Schuko 16 A	Data socket 2 RJ45	Compressed air connection 3/8"	Protection		IP degree	
	125 A	63 A	32 A	16 A				MCB	RCD	IP 20	IP 44
6H0 00 02					4						I
6H0 00 01					10						I
6H0 00 09					4	1				I	
6H0 01 07 LA				1	4		I				I

Suspension-type socket combinations, plastic, enclosures 6H0, 6H1, 6H2

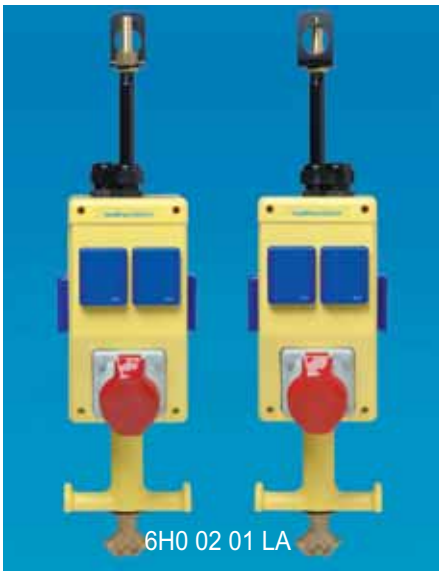

Suspension-type combination, plastic enclosure, wired ready for connection

Part no.	CEE panel sockets 5-pole 400 V				Schuko 16 A	Data socket 2 RJ45	Compressed air connection 3/8"	Protection		IP degree	
	125 A	63 A	32 A	16 A				MCB	RCD	IP 20	IP 44
6H0 02 01 LA				2	6		I				I
6H1 00 05					4				4/40/0,03 A		I
6H1 01 01				1	6				4/40/0,03 A		I
6H1 02 02				2	2			1 x C16/3-pole	1 x B16/1-pole		I
6H1 30 01 LA			1	1	2		I	1 x C16/3-pole	1 x B16/1-pole		I
6H2 30 02 LA			1	1	2		I	1 x C16/3-pole	4/40/0,03 A 1 x B16/1-pole		I

Suspension-type socket combinations, plastic, enclosures 6H3, 6H4, 6H5

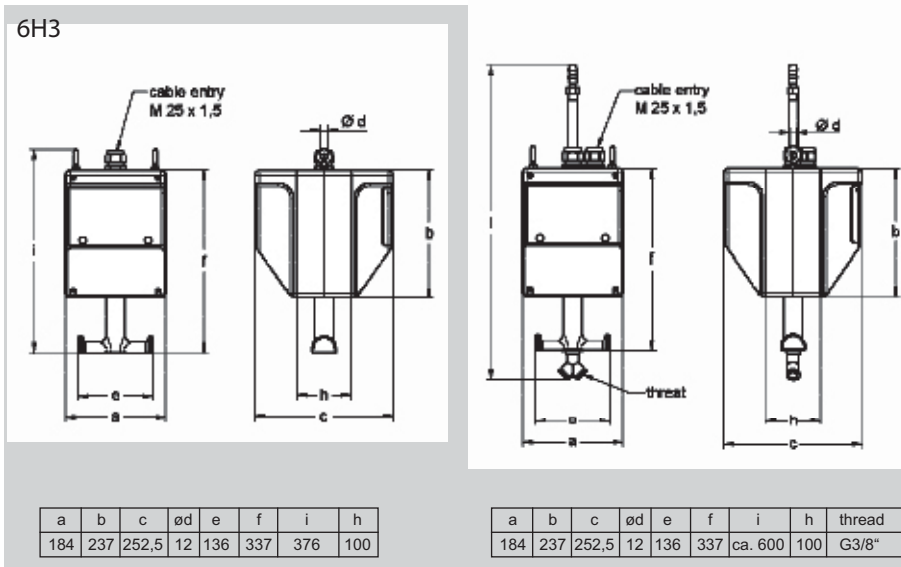

10

Suspension-type combination, plastic enclosure, wired ready for connection

Part no.	CEE panel sockets 5-pole 400 V				Schuko 16 A	Data socket 2 RJ45	Compressed air connection 3/8"	Protection		IP degree	
	125 A	63 A	32 A	16 A				MCB	RCD	IP 20	IP 44
6H4 01 02 LA				1	6	2	I	1 x C16/3-pole 2 x B16/1-pole	4/40/0,03 A	I	
6H4 11 01			1		6	2		1 x C32/3-pole	4/40/0,03 A 3 x B16/1-pole		I
6H5 31 01 LA			1	2	2		I	1 x C32/3-pole 2 x B16/1-pole	4/63/0,03 A 2 x C16/3-pole		I
6H4 41 01		1	1		2			1 x C32/3-pole	4/63/0,03 A 2 x B16/1-pole		I

Stainless steel pillars

Pillars made of stainless steel, steel grade 1.4301

Available on request:

Special dimensions and lacquer varnishes acc. to RAL colour chart.

With connections for compressed air and water.

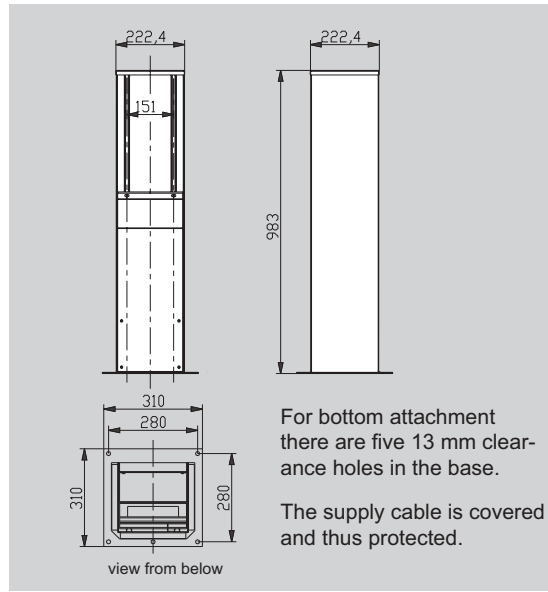

For installation of these enclosure series:

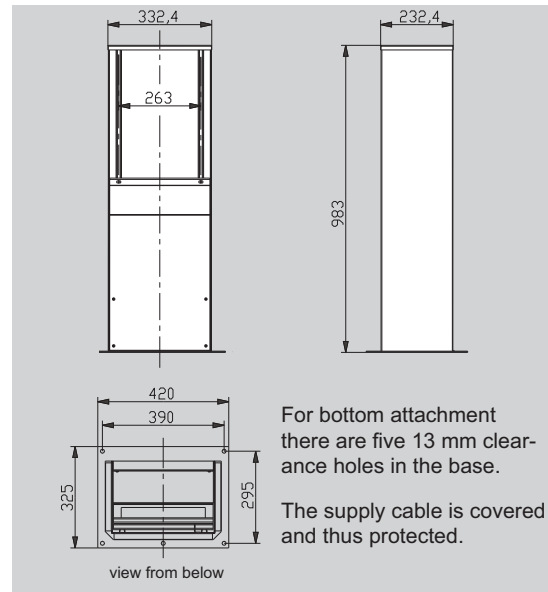

For installation of these enclosure series:

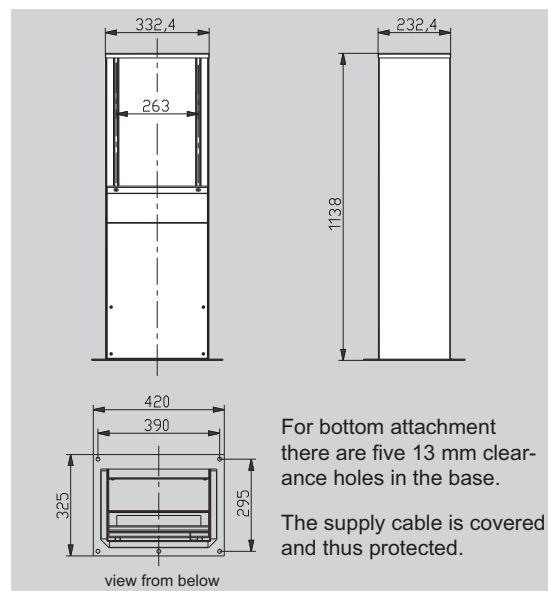

For installation of these enclosure series:

Suitable socket combination series for installation in stainless steel pillars



Enclosure series: 691, 692, 698

Part no.: 620 99 12*



Enclosure series: 698

Part no.: 620 99 18*



Enclosure series: 695

Part no.: 620 99 15*



Enclosure series: 699

Part no.: 620 99 19*



Enclosure series: 682

Part no.: 620 99 22*



Enclosure series: 689

Part no.: 620 99 29*



Enclosure series: 646, 647

Part no.: 620 99 46*



Enclosure series: 685

Part no.: 620 99 25*

* Part number of the (empty) stainless steel pillar which can be equipped with the socket combi shown above

CEEtyp
Socket
combinations
680

The main idea behind
Walther socket combinations
is the enclosure modularity.

Due to an extensive range of
enclosures, the manifold
equipment requirements of
our customers can be met.



Cable grommets
for cable diameters
of 14 - 58 mm

**deeper
enclosure bottom
allows for more
industrial solutions**

- Isolating transformers up to 1,5 kVA mountable
- LV HRC fuse switch disconnector size 00 can be integrated in the socket combination
- Supply cables with cross sections up to 95 mm² can be connected



Enclosure sizes



Enclosure 682
Dimensions: H x W x D:
404 x 290 x 171 mm

Enclosure 682 TB
Dimensions: H x W x D:
404 x 290 x 212 mm



Planning aid for socket combinations according to your requirements

Our socket combinations are too numerous to list here. Therefore we have designed this planning aid to help you with the inquiry in case you require other combination configurations. Please use separate sheets for combinations with different specifications.

Fax Inquiry: +49 (0) 6351/475-205

Tel.-no.: +49 (0) 6351/475-221 or -234

Sender:

Name, first name: _____

Function / Department: _____

Company: _____

Street address: _____

Postal code, place: _____

Country: _____

E-mail / Fax: _____

Object: _____

Quantity: _____

Required delivery date: _____

Date: _____

Wall mount combination:

- q Plastic (PC/ABS)
- q Solid rubber
- q Plastic (PBT)

Suspension-type combi:

- q Plastic (PC/ABS)

Portable combination:

- q Solid rubber
- q Plastic
- q Hard polyethylene

Portable power strips:

- q Plastic (PC/ABS)
- q Solid rubber

Mounted in stainless steel pillar:

- q Plastic (PC/ABS)
- q Plastic (PBT)
- q Solid rubber

Protection degree:

- q splash proof IP 44
- q watertight IP 67

Equipped with: (please ask for more information if you require a socket combination with CEPro plugs and sockets)

Designation	Type of socket				MCB		Neozed fuse base Poles	Electrical interlocking	other
	Qty.	Poles	Current	Voltage	Current	Characteristic			
Schuko									
CEEtyp									
CEEtyp									
CEEtyp									
CEEtyp									
Norvo < 50 V									
Norvo < 50 V									

RCD
 Rated current: q 25 A q 40 A q 63 A q 80 A q 100 A q 125 A
 Leakage current: q 0,03 A q 0,3 A q 0,5 A
 Number of poles: q 2 P q 4 P q RCBO Quantity:

Double data socket RJ 45 Kat. 6 q IP 20 q IP 44 q IP 67

Transformer S = VA U_{pr.} V U_{sec.} V

Control lamp q yes q no **Emergency stop** q yes q no

Connection
 Wall mount combi: Supply line from: M-entry Terminal block
 q top q 20 q 25 q 32 q without q tie line mm²
 q bottom q 50 q 63 q ring main mm²
 Portable combi: q plug + connecting line..... mm², length: m q appliance inlet
 Power strip: q plug + connecting line..... mm², length: m

Circuit diagram/installation dimension limitation: H: W:

Consumer boxes, plastic, wall-mount
single-row, 13 MCB module widths

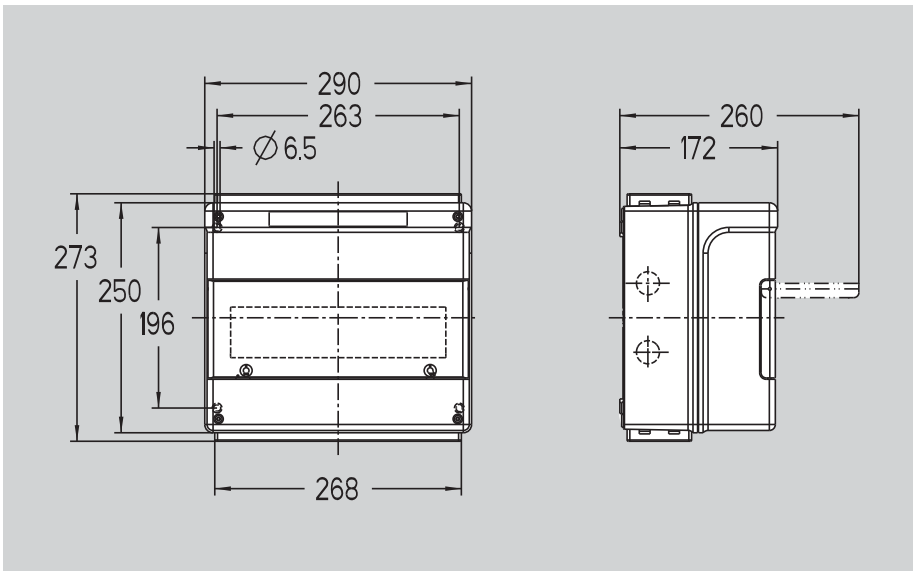

IV 113 15



IV 113 26

AutoboxX

Walther Consumer Boxes

Plastic PC/ABS, similar grey RAL 7035
Rated voltage AC 230 / 400 V
Transparent cover with locking facility
opens upwards

equipped with:

- 1 x DIN rail for snap-mounted devices
- 2 x PE/N terminal, 17-pole
- 1 x mounting instruction
- 1 x labeling strip
- 4 x sealing plug
- 1 x cable cover

Cable entry		Part number
<p>Seal membranes - IP 67</p> <p>10 x Ø 7-12 mm 4 x Ø 7-15 mm 4 x Ø 11-20 mm 1 x Ø 16-29 mm</p>	<p>top and bottom</p>	IV 113 15
<p>Knockouts - with complete cable glands IP 65</p> <p>1 x M 32/40 2 x M 25 6 x M 20</p>	<p>top and bottom</p>	IV 113 26

Consumer boxes, plastic, wall-mount
double-row, 26 MCB module widths

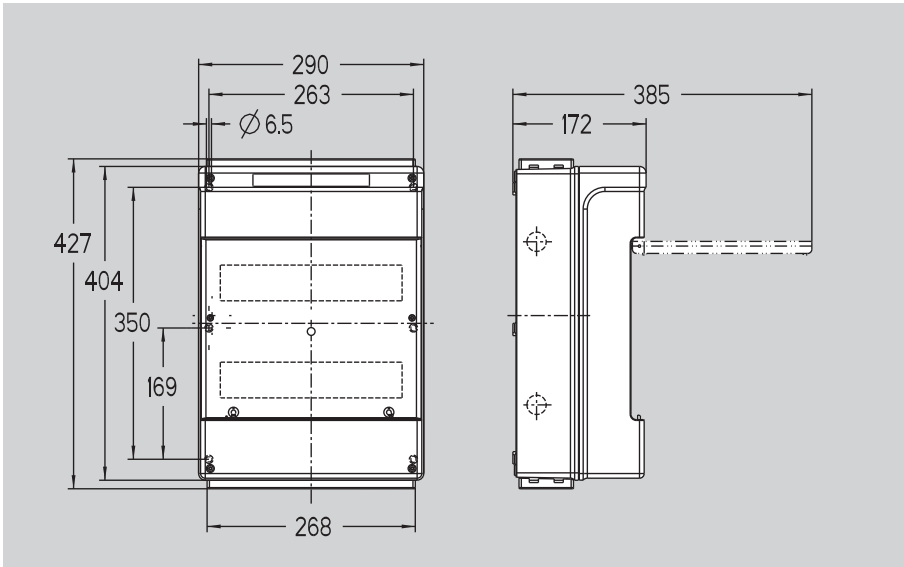

IV 126 15

AutoboxX

Walther Consumer Boxes

Plastic PC/ABS, similar grey RAL 7035
Rated voltage AC 230 / 400 V
Transparent cover with locking facility
opens upwards

equipped with:

- 2 x DIN rail for snap-mounted devices
- 2 x PE/N terminal, 17-pole
- 1 x mounting instruction
- 1 x labeling strip
- 4 x sealing plug
- 1 x cable cover

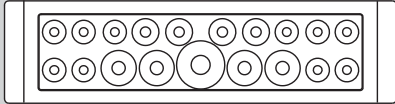
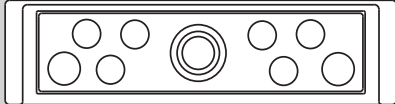

IV 126 26

Cable entry		Part number
<p>Seal membranes - IP 67</p> <p>10 x Ø 7-12 mm 4 x Ø 7-15 mm 4 x Ø 11-20 mm 1 x Ø 16-29 mm</p>	 <p style="text-align: center;">top and bottom</p>	<p style="text-align: center;">IV 126 15</p>
<p>Knockouts - with complete cable glands IP 65</p> <p>1 x M 32/40 2 x M 25 6 x M 20</p>	 <p style="text-align: center;">top and bottom</p>	<p style="text-align: center;">IV 126 26</p>

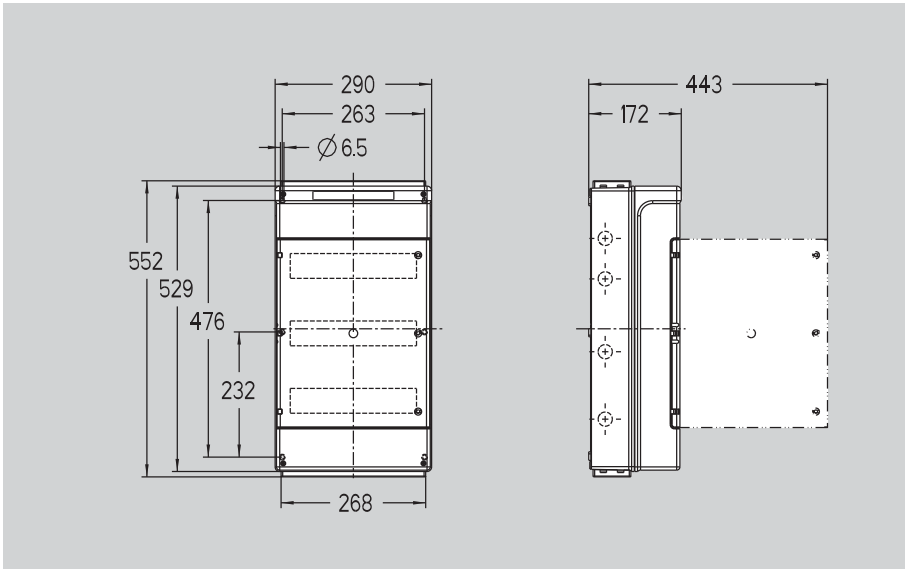

IV 139 15

AutoboxX

Walther Consumer Boxes

Plastic PC/ABS, similar grey RAL 7035
Rated voltage AC 230 / 400 V
Transparent cover with locking facility
opens upwards

equipped with:

- 3 x DIN rail for snap-mounted devices
- 4 x PE/N terminal, 17-pole
- 1 x mounting instruction
- 1 x labeling strip
- 4 x sealing plug
- 1 x cable cover



IV 139 26

11

Cable entry		Part number
<p>Seal membranes - IP 67</p> <p>10 x Ø 7-12 mm 4 x Ø 7-15 mm 4 x Ø 11-20 mm 1 x Ø 16-29 mm</p>	<p>top and bottom</p>	IV 139 15
<p>Knockouts - with complete cable glands IP 65</p> <p>1 x M 32/40 2 x M 25 6 x M 20</p>	<p>top and bottom</p>	IV 139 26



identical.

By means of the keyway in the socket (which identifies the hour position) respectively by means of the guide groove inside the plug, the frequencies can be distinguished.

Due to constructional reasons the hour positions 5, 6 and 7 can not be used. The hour positions 1, 8 and 9 are reserved for future standardisations.

Systems below 50 V are safety extra-low voltage systems and do not require an earth contact.

These different keyway widths prevent the insertion of 32/30 A plugs into 16/20 A sockets.

To distinguish between different voltages and frequencies there is a major keyway in the socket at 6 hour position. The different widths of the keyways are:

It is possible and in accordance with the standard to insert 32/30A plugs into 16/20 A sockets if voltage and frequency are identical.

- 4 mm for 32/30 A plugs
- 7 mm for 16/20 A plugs

It is also possible to insert a 2-pole plug into a 3-pole socket if voltage and frequency are

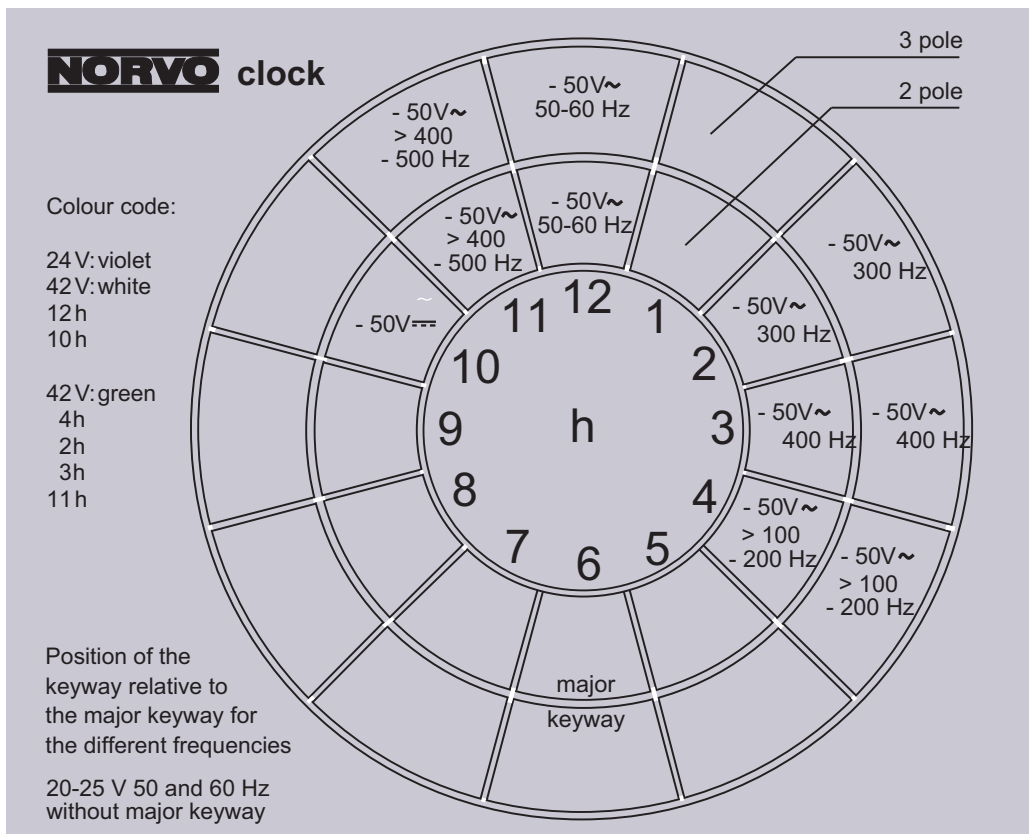

Application areas of extra-low voltage systems are for example:

- boiler companies
- pipeline construction
- generating stations
- mobile lighting systems
- tank cleaning systems

Norvo
Plugs & Sockets
for extra low voltages up to 50 V

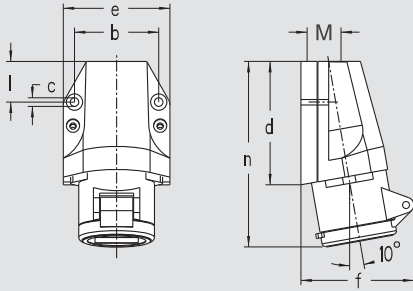

Amp.	16		32	
Poles	2	3	2	3
b	54,5	54,5	54,5	54,5
c	5,2	5,2	5,2	5,2
d	81	81	81	81
e	70	70	70	70
f	72	72	72	72
l	28	28	28	28
n	119	119	119	119
M	25	25	25	25

NORVO wall sockets,
external fixing,
1 top cable entry,
IP 44 ▲

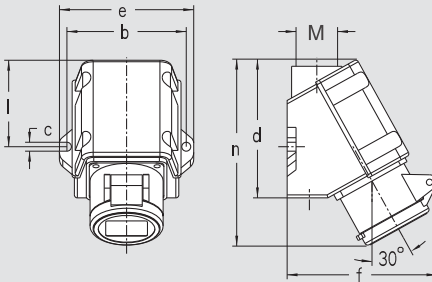

Amp.	16		32	
Poles	2	3	2	3
b	80	80	80	80
c	6,2	6,2	6,2	6,2
d	93	93	93	93
e	90	90	90	90
f	93	93	93	93
l	60	60	60	60
n	125	125	125	125

NORVO wall sockets,
external fixing,
top cable entry 1 x PG 21,
bottom cable entry 2 x PG 16,
IP 44 ▲

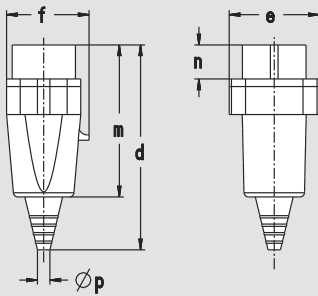

Amp.	16		32	
Poles	2	3	2	3
d	135	135	135	135
e	59	59	59	59
f	55	55	55	55
m	99	99	99	99
n	22,5	22,5	22,5	22,5
Øp	8/21	8/21	8/21	8/21

NORVO plugs,
with flexible cable entry,
IP 44 ▲

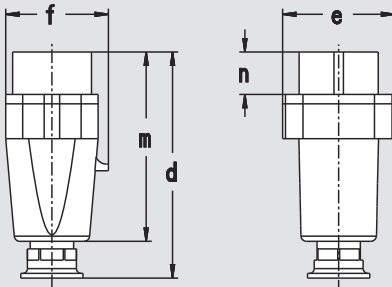

Amp.	16		32	
Poles	2	3	2	3
d	128	128	128	128
e	59	59	59	59
f	55	55	55	55
m	99	99	99	99
n	22,5	22,5	22,5	22,5
Øp	7,5-14,5	7,5-14,5	7,5-14,5	7,5-14,5

NORVO plugs,
with trumpet gland, PG 16
IP 44 ▲

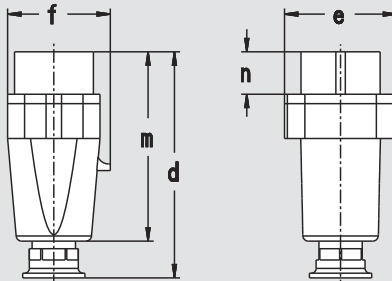

Amp.	16		32	
Poles	2	3	2	3
d	128	128	128	128
e	59	59	59	59
f	55	55	55	55
m	99	99	99	99
n	22,5	22,5	22,5	22,5
Øp	7,5-19,5	7,5-19,5	7,5-19,5	7,5-19,5

NORVO plugs,
with trumpet gland, PG 21
IP 44 ▲

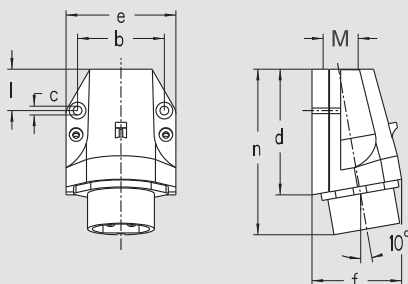

Amp.	16		32	
Poles	2	3	2	3
b	54,5	54,5	54,5	54,5
c	5,2	5,2	5,2	5,2
d	81	81	81	81
e	70	70	70	70
f	68	68	68	68
l	28	28	28	28
n	105	105	105	105
M	28	28	28	28

NORVO wall mount appliance inlets,
external fixing,
1 top cable entry,
IP 44 ▲

Norvo plugs & sockets for low voltages up to 50 V

Ampère	Poles	24~ V 50/60 Hz		42~V 50/60 Hz		42~V 100/200 Hz		42~V 300 Hz		42~V 400 Hz		42~V >400/500Hz		42 ... V —					
		2-pole —	3-pole —	2-pole 12 h	3-pole 12 h	2-pole 4 h	3-pole 4 h	2-pole 2 h	3-pole 2 h	2-pole 3 h	3-pole 3 h	2-pole 11 h	3-pole 11 h	2-pole 10 h					
Part numbers																			
16	2	10 110	10 111	10 112	10 113	10 114	10 115	10 116	10										
16	3	10 150	10 151	10 152	10 153	10 154	10 155	10											
32	2	11 110	11 111	11 112	11 113	11 114	11 115	11 116	10										
32	3	11 150	11 151	11 152	11 153	11 154	11 155	10											
16	2	10 100	10 101	10 102	10 103	10 104	10 105	10 106	10										
16	3	10 140	10 141	10 142	10 143	10 144	10 145	10											
32	2	11 100	11 101	11 102	11 103	11 104	11 105	11 106	10										
32	3	11 140	11 141	11 142	11 143	11 144	11 145	10											
16	2	10 280	10 281	10 282	10 283	10 284	10 285	10 286	10										
16	3	10 290	10 291	10 292	10 293	10 294	10 295	10											
32	2	11 280	11 281	11 282	11 283	11 284	11 285	11 286	10										
32	3	11 290	11 291	11 292	11 293	11 294	11 295	10											
16	2	10 210	10 211	10 212	10 213	10 214	10 215	10 216	10										
16	3	10 250	10 251	10 252	10 253	10 254	10 255	10											
32	2	11 210	11 211	11 212	11 213	11 214	11 215	11 216	10										
32	3	11 250	11 251	11 252	11 253	11 254	11 255	10											
16	2	10 220	10 221	10 222	10 223	10 224	10 225	10 226	10										
16	3	10 260	10 261	10 262	10 263	10 264	10 265	10											
32	2	11 220	11 221	11 222	11 223	11 224	11 225	11 226	10										
32	3	11 260	11 261	11 262	11 263	11 264	11 265	10											
16	2	10 800	10 801	10 802	10 803	10 804	10 805	10 806	10										
16	3	10 840	10 841	10 842	10 843	10 844	10 845	10											
32	2	11 800	11 801	11 802	11 803	11 804	11 805	11 806	10										
32	3	11 840	11 841	11 842	11 843	11 844	11 845	10											

Availability of not listed clock positions on request

Norvo
Plugs & Sockets
for extra low voltages up to 50 V

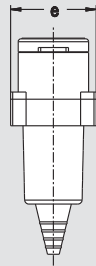
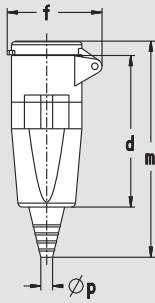

Amp.	16		32	
Poles	2	3	2	3
d	150	150	150	150
e	59	59	59	59
f	67	67	67	67
m	104	104	104	104
Øp	8/21	8/21	8/21	8/21

NORVO couplers,
with flexible cable entry,
IP 44 ▲

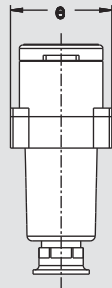
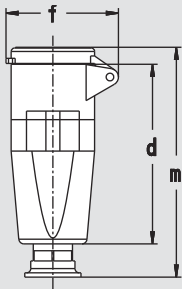

Amp.	16		32	
Poles	2	3	2	3
d	143	143	143	143
e	59	59	59	59
f	67	67	67	67
m	104	104	104	104
Øp	7,5 - 14,5			

NORVO couplers,
with trumpet gland, PG 16
IP 44 ▲

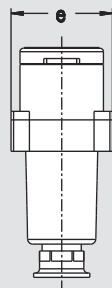
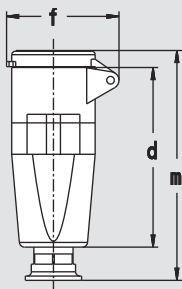

Amp.	16		32	
Poles	2	3	2	3
d	143	143	143	143
e	59	59	59	59
f	67	67	67	67
m	104	104	104	104
Øp	10-19,5	10-19,5	10-19,5	10-19,5

NORVO couplers,
with trumpet gland, PG 21
IP 44 ▲

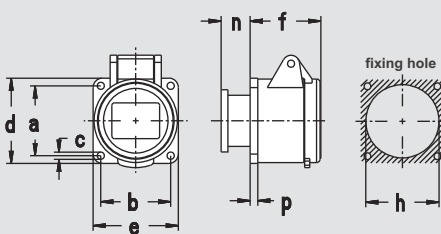

Amp.	16		32	
Poles	2	3	2	3
a	41	41	41	41
b	41	41	41	41
c	4,2	4,2	4,2	4,2
d	50	50	50	50
e	50	50	50	50
f	42	42	42	42
h	40	40	40	40
n	18	18	18	18
p	4	4	4	4

NORVO panel sockets, straight,
flange dimensions 50 x 50 mm,
IP 44 ▲

fixing dimensions = a + b, flange dimensions = d + e

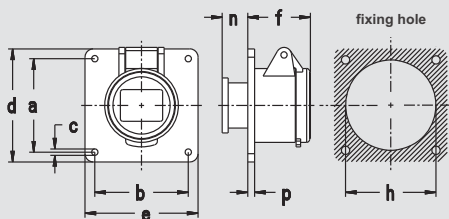

Amp.	16		32	
Poles	2	3	2	3
a	60	60	60	60
b	60	60	60	60
c	4,2	4,2	4,2	4,2
d	75	75	75	75
e	75	75	75	75
f	42	42	42	42
h	40	40	40	40
n	18	18	18	18
p	4	4	4	4

NORVO panel sockets, straight,
flange dimensions 75 x 75 mm,
IP 44 ▲

fixing dimensions = a + b, flange dimensions = d + e

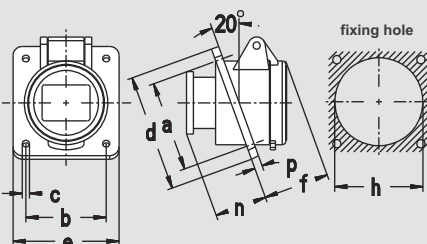

Amp.	16		32	
Poles	2	3	2	3
a	53	53	53	53
b	47	47	47	47
c	4,5	4,5	4,5	4,5
d	68	68	68	68
e	62	62	62	62
f	38	38	38	38
h	55	55	55	55
n	30	30	30	30
p	4,5	4,5	4,5	4,5

NORVO panel sockets, angled,
flange dimensions 68 x 62,
IP 44 ▲

fixing dimensions = a + b, flange dimensions = d + e

Norvo plugs & sockets for low voltages up to 50 V

Ampère	Poles	24~V 50/60 Hz		42~V 50/60 Hz		42~V 100/200 Hz		42~V 300 Hz		42~V 400 Hz		42~V >400/500Hz		42...V —					
		2-pole —	3-pole —	2-pole 12 h	3-pole 12 h	2-pole 4 h	3-pole 4 h	2-pole 2 h	3-pole 2 h	2-pole 3 h	3-pole 3 h	2-pole 11 h	3-pole 11 h	2-pole 10 h					
Part numbers																			
16	2	10 380	10 381	10 382	10 383	10 384	10 385	10 386	10										
16	3	10 390	10 391	10 392	10 393	10 394	10 395	10 386	10										
32	2	11 380	11 381	11 382	11 383	11 384	11 385	11 386	10										
32	3	11 390	11 391	11 392	11 393	11 394	11 395	11 386	10										
16	2	10 310	10 311	10 312	10 313	10 314	10 315	10 316	10										
16	3	10 350	10 351	10 352	10 353	10 354	10 355	10 316	10										
32	2	11 310	11 311	11 312	11 313	11 314	11 315	11 316	10										
32	3	11 350	11 351	11 352	11 353	11 354	11 355	11 316	10										
16	2	10 320	10 321	10 322	10 323	10 324	10 325	10 326	10										
16	3	10 360	10 361	10 362	10 363	10 364	10 365	10 326	10										
32	2	11 320	11 321	11 322	11 323	11 324	11 325	11 326	10										
32	3	11 360	11 361	11 362	11 363	11 364	11 365	11 326	10										
16	2	10 400	10 401	10 402	10 403	10 404	10 405	10 406	10										
16	3	10 440	10 441	10 442	10 443	10 444	10 445	10 406	10										
32	2	11 400	11 401	11 402	11 403	11 404	11 405	11 406	10										
32	3	11 440	11 441	11 442	11 443	11 444	11 445	11 406	10										
16	2	10 600	10 601	10 602	10 603	10 604	10 605	10 606	10										
16	3	10 640	10 641	10 642	10 643	10 644	10 645	10 606	10										
32	2	11 600	11 601	11 602	11 603	11 604	11 605	11 606	10										
32	3	11 640	11 641	11 642	11 643	11 644	11 645	11 606	10										
16	2	10 500	10 501	10 502	10 503	10 504	10 505	10 506	10										
16	3	10 540	10 541	10 542	10 543	10 544	10 545	10 506	10										
32	2	11 500	11 501	11 502	11 503	11 504	11 505	11 506	10										
32	3	11 540	11 541	11 542	11 543	11 544	11 545	11 506	10										

Availability of not listed clock positions on request

CEPro
Plugs & Sockets
 - power and control in one unit

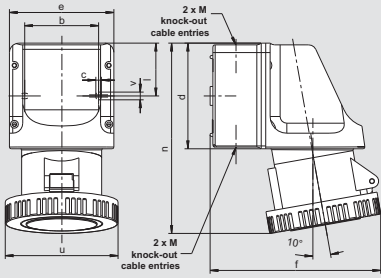

Amp.	16		32
Poles	3	5	5
b	66,5	66,5	66,5
c	5	5	5
d	96	96	96
e	95	95	95
f	140	147	156
l	47,5	47,5	47,5
n	164	164	176
u	72	88	103
v	7	7	7
M	20/25	20/25	20/25

Wall sockets,
 internal fixing,
 2 knock-out cable entries on top and bottom
 IP 67

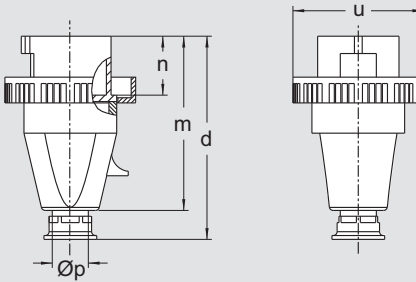

Amp.	16		32
Poles	3	5	5
d	126	139	166
m	110	114	135
n	37	37	46
u	72	88	103
Øp	7,5-12,5	10-19,5	18-24,5

Plugs,
 trumpet gland,
 IP 67

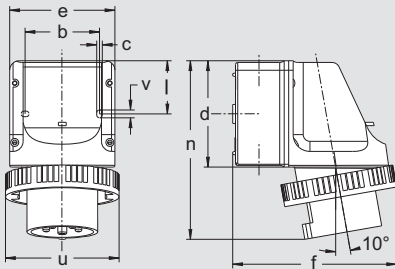

Amp.	16		32
Poles	3	5	5
b	66,5	66,5	66,5
c	5	5	5
d	96	96	96
e	95	95	95
f	140	140	150
l	47,5	47,5	47,5
n	154	154	164
u	72	88	103
v	7	7	7
M	20/25	20/25	20/25

Wall mount appliance inlets,
 internal fixing,
 2 knock-out cable entries on top and bottom,
 IP 67

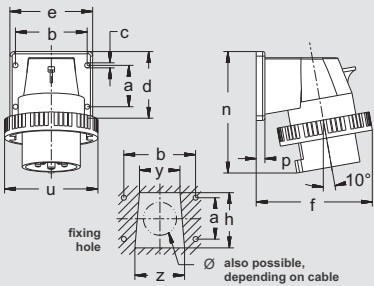

Amp.	16		32
Poles	3	5	5
a	30	40	45
b	55	68	78
c	5,5	5,5	5,5
d	52	66	75
e	65	80	90
f	81	103	117
h	38	52	60
n	98	113	131
p	9,5	9,5	9,5
u	72	88	103
y	30	38	44
z	36	46	54

Panel mount appliance inlets, angled,
 with screwed flange,
 IP 67

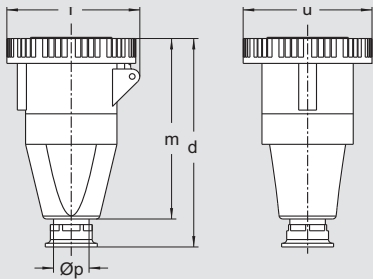

Amp.	16		32
Poles	3	5	5
d	136	150	177
f	78	91	105
m	121	126	149
u	72	88	103
Øp	7,5-12,5	10-19,5	18-24,5

Couplers,
 trumpet gland,
 IP 67

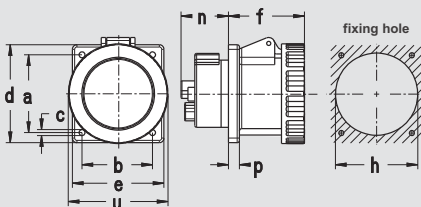

Amp.	16		32
Poles	3	5	5
a	47	60	60
b	47	60	60
c	5,5	5,5	5,5
d	62	80	80
e	62	80	80
f	57	59	70
h	46	67	71
n	22	22	23
p	8,5	8,5	8,5
u	72	88	103

Panel sockets, straight,
 with screwed flange,
 IP 67

CEPro plugs and sockets for power and control

Ampère	Poles	Max. no. of control contacts	110 V 50 a. 60 Hz		230 V 50 a. 60 Hz		400 V 50 a. 60 Hz		440 V 60 Hz	500 V 50 a. 60 Hz				
			3pole 4h	5pole 4h	3pole 6h	5pole 9h	3pole 9h	5pole 6h	5pole 11h	3pole 7h	5pole 7h			
Part numbers														
16	3	6 pcs.*	7 119 304	7 119 306	7 119 309									
16	5	9 pcs.*	7 119 504	7 119 509	7 119	7 119 511	7 119 507							
32	5	10 pcs.*	7 139 504	7 139 509	7 139	7 139 511	7 139 507							
16	3	6 pcs.*	7 219 304	7 219 306	7 219 309									
16	5	9 pcs.*	7 219 504	7 219 509	7 219	7 219 511	7 219 507							
32	5	10 pcs.*	7 239 504	7 239 509	7 239	7 239 511	7 239 507							
16	3	6 pcs.*	7 618 304	7 618 306	7 618 309									
16	5	9 pcs.*	7 618 504	7 618 509	7 618	7 618 511	7 618 507							
32	5	10 pcs.*	7 638 504	7 638 509	7 638	7 638 511	7 638 507							
16	3	6 pcs.*	7 619 304	7 619 306	7 619 309									
16	5	9 pcs.*	7 619 504	7 619 509	7 619	7 619 511	7 619 507							
32	5	10 pcs.*	7 639 504	7 639 509	7 639	7 639 511	7 639 507							
16	3	6 pcs.*	7 319 304	7 319 306	7 319 309									
16	5	9 pcs.*	7 319 504	7 319 509	7 319	7 319 511	7 319 507							
32	5	10 pcs.*	7 339 504	7 339 509	7 339	7 339 511	7 339 507							
16	3	6 pcs.*	7 419 304	7 419 306	7 419 309									
16	5	9 pcs.*	7 419 504	7 419 509	7 419	7 419 511	7 419 507							
32	5	10 pcs.*	7 439 504	7 439 509	7 439	7 439 511	7 439 507							



* Please order crimp and glass fibre cable contacts separately

CEPro
Plugs & Sockets
 - power and control in one unit

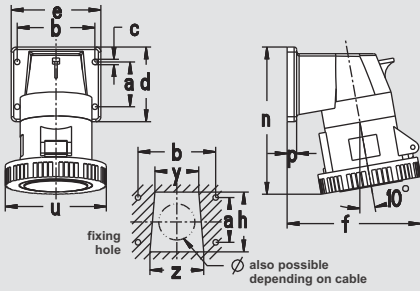

Amp.	16	32
Poles	3	5
a	30	40
b	55	68
c	5,5	5,5
d	52	66
e	65	80
f	88	108
h	38	52
n	109	123
p	9,5	9,5
u	72	88
y	30	38
z	38	46

Panel sockets, angled,
 with screwed flange enclosure,
 IP 67

Amp.	16	32
Poles	3	5
k	70	86
n	41	42
u	60	76

Protective caps,
 for plugs and appliance inlets,
 with attachment kit
 IP 67



Power contact section

The CEPro plug and socket system is similar to the CEE system, the power contacts are arranged in a circle. However, in CEPro devices, phase, neutral and earth positions are arranged at a different angle, which prevents incorrect mating between CEE and CEPro system.

Control contact section

The pins and sleeves are from WALTHER's widely used and tested PROCON range of industrial connectors. These control contacts are shielded from the power contacts which prevents the risk of flash-over between the two circuits.

Termination method inside the control contact section

The cables are connected to the different control contacts by means of crimping. An important advantage of the crimping technique is that a gastight connection can be made between contact and cable con-

ductor, thereby establishing a constantly low contact resistance.

The crimp contacts snap into place in the contact cavities and can be undone with a removal tool.

Scope of delivery

CEPro devices are provided with screw terminal power contacts. The control contact section comes without pins and sleeves so that it can be equipped by the user himself with the required crimp contacts.



WALTHER-CEPro cable

In addition to the CEPro plugs and sockets, WALTHER also offers special hybrid cables which guarantee safe transmission of power and control signals.

All cables consist of fine wire copper strands. The wires are twisted together and shielded in pairs.

This avoids influence by switching impulses from the power section and a good damping of interference from the outside is achieved.

The application is suitable for a temperature range of - 30 up to + 80 °C with flexing cable, but the flexing radius should not be lower than 7.5 x cable diameter.

The wires in the cables are tested against each other and the power current section is tested to the control part with 3500 V. The outside coating is made of polyurethane.

CEPro plugs and sockets in connection with CEPro cable ensure a safe power and signal transmission, guaranteeing the requirements of a „safe connection“ according to VDE 0100 T 410.

CEPro plugs and sockets for power and control

Ampère	Poles	Max. no. of control contacts	110 V 50 a. 60 Hz		230 V 50 a. 60 Hz		400 V 50 a. 60 Hz		440 V 60 Hz		500 V 50 a. 60 Hz		Part numbers	5	5	5	
			3pole 4h	5pole 4h	3pole 6h	5pole 9h	3pole 9h	5pole 6h	5pole 11h	3pole 7h	5pole 7h						
16	3	6 pcs.*	7 518 304	7 518 304	7 518 309	7 518 309	7 518 309	7 518 309	7 518 309	7 518 309	7 518 309	7 518 309	7 518 309	7 518 309	7 518 309	7 518 309	7 518 309
16	5	9 pcs.*	7 518 504	7 518 504	7 518 509	7 518 509	7 518 509	7 518 509	7 518 509	7 518 509	7 518 509	7 518 509	7 518 509	7 518 509	7 518 509	7 518 509	7 518 509
32	5	10 pcs.*	7 538 504	7 538 504	7 538 509	7 538 509	7 538 509	7 538 509	7 538 509	7 538 509	7 538 509	7 538 509	7 538 509	7 538 509	7 538 509	7 538 509	7 538 509
* Please order crimp and glass fibre cable contacts separately																	
16	3		613 300	613 300													10
16	5		613 500	613 500													10
32	5		633 500	633 500													10



Application areas

This system is ideal for installations and machines which operate or utilise both power and control systems: e.g. production planning systems (PPS) or computer integrated manufacturing (CIM).

Other applications are for example connection to end-users with network-backed-up systems, like:

- crane controls
- light- and stage control
- container control etc.

CEPro plugs and sockets can transmit both power and control signals simultaneously within one compact system.

CEPro devices can be plugged and withdrawn under load.

CEPRO coding

In installations where several CEPro sockets are in close proximity but performing different functions, the sockets and plugs have to be made unmistakable. This is achieved either by **mechanical** or **electronic** coding.

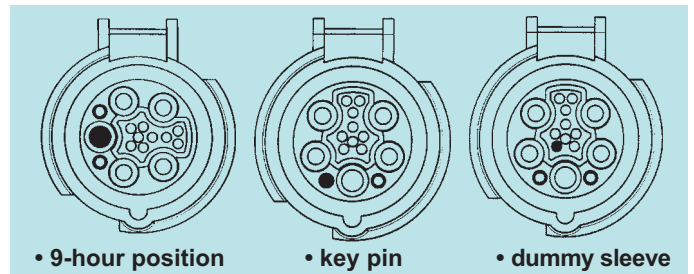

Mechanical coding:

- Use of screwable key pins in connection with blanking plugs
- Allocation of different hour positions
- Snapping-in of blind sleeves in the control contact section.

Electronic coding:

Electrical connections are only set-up in dependence of a programmable logic control (PLC).

Since the complete control contact section is lagging the power contact section when plugging, there is a large number of different electrical locking possibilities by using different pairs of control contacts.

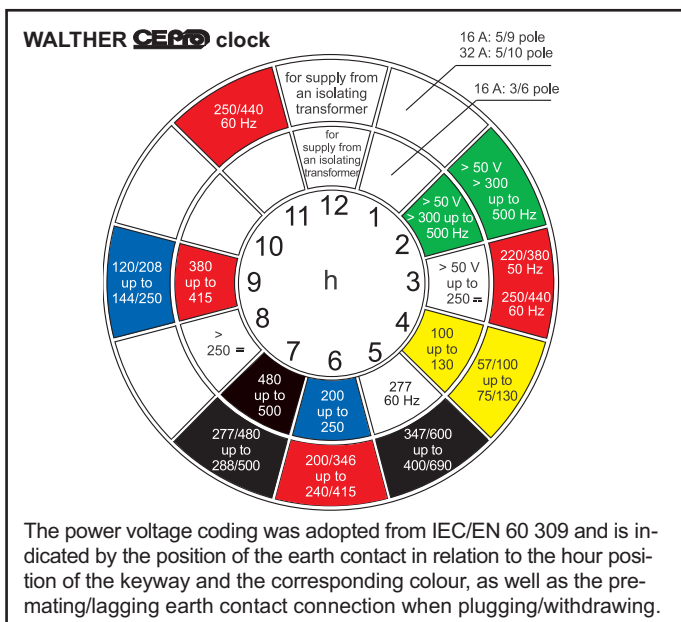

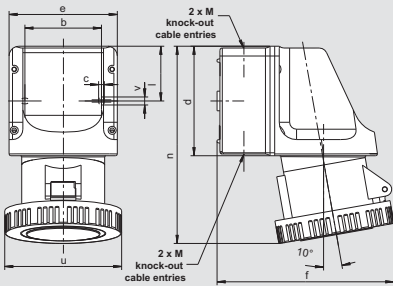

Amp.	32
Poles	4
b	66,5
c	5
d	96
e	95
f	154
l	47,5
n	176
u	96
v	7
M	20/25

Wall socket,
internal fixing,
2 knock-out cable entries on top and bottom,
IP 67

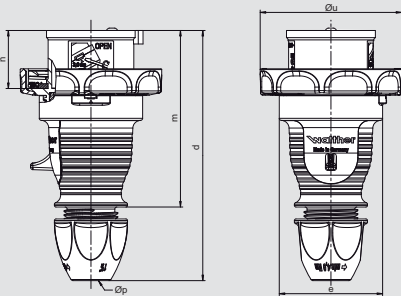

Amp.	32
Poles	4
d	150-161
Ø e	Ø 65
m	111
n	36,5
Ø u	Ø 81
Ø p	10 - 22,5

Plug, with screw terminal connection
with cable gland, IP 67

or

Plug, screwless („SL“),
with insulation displacement connection,
with cable gland, IP 67

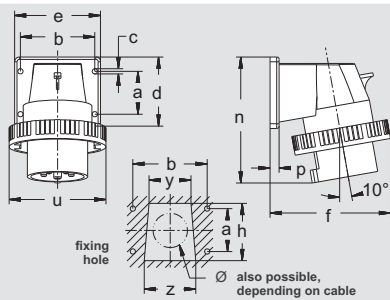

Amp.	32
Poles	4
a	45
b	78
c	5,5
d	75
e	90
f	111
h	60
n	131
p	9,5
u	96
y	44
z	54

fixing dimensions = a + b,
flange dimensions = d + e

Panel mount appliance inlet, angled,
screwed flange enclosure,
IP 67

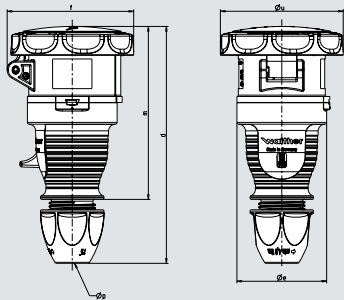

Amp.	32
Poles	4
d	174-183
Ø e	Ø 72
f	95
m	142
Ø u	Ø 95
Ø p	10 - 22,5

Coupler, with screw terminal connection,
with cable gland, IP 67

or

Coupler, screwless („SL“),
with insulation displacement connection,
with cable gland, IP 67

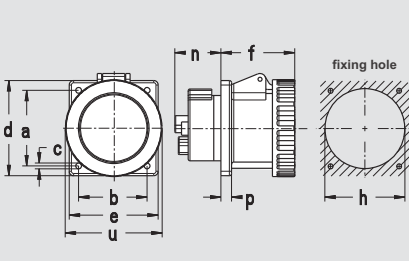

Amp.	32
Poles	4
a	60
b	60
c	5,5
d	75
e	75
f	65
h	60
n	27
p	9
u	96

fixing dimensions = a + b,
flange dimensions = d + e



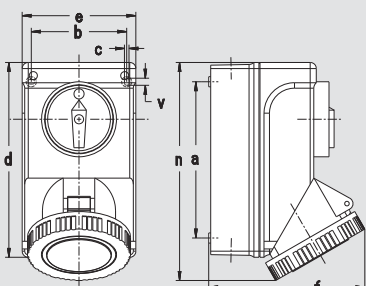







Panel socket, straight,
fingerproof acc. to BGV A3,
IP 67



Amp.	32
Poles	4
a	154
b	94
c	4,5
d	193
e	113
f	154
n	215
v	7
M	25

Wall socket,
with switch and double interlocking,
with 3-pole switch,
IP 67

Container Plugs and Sockets

Ampère	Poles	400 - 440 V 50 - 60 Hz 4-pole 3 h		 3 P + E
Part numbers				
32	4	139 403	5	 139403
32	4	239 403	10	 239
32	4	239 403 SL	10	 239
32	4	639 403	10	 639403
32	4	339 403	10	 339403
32	4	339 403 SL	10	 339403
32	4	439 403	10	 439403
32	4	AT 139 403	1	 AT139403

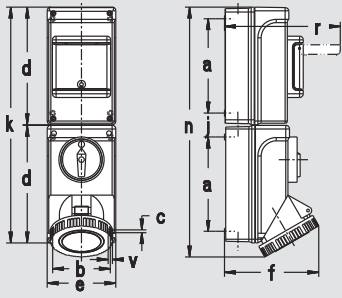

Amp.	32
Poles	4
a	154
b	94
c	4,5
d	193
e	113
f	154
j	39
k	387
n	409
r	191
v	7
M	20/25

Wall socket,
with switch and DIN-rail,
with double interlocking,
switch 3-pole,
IP 67 ☹☹

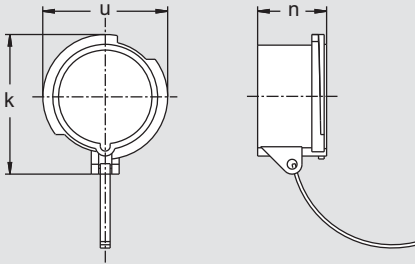





Amp.	32
Poles	4
a	90
b	50
u	82

Protective cap,
for plugs and appliance inlets,
with attachment kit,
IP 67 ☹☹



Container Plugs and Sockets

Ampère	Poles	400 - 440 V 50 - 60 Hz 4-pole 3 h		 3 P + E
32	4	AU 139 403 TS	1	 AT139403
		633 400 for 32 A 4-pole	10	 633400

Container wall socket

Always 3-pole + \ominus 3 h.
Two cable entries on top and bottom. Cover fixing screws made of stainless steel.

The worldwide network of container loading stations, whether in

- n ships
- n harbours
- n airports
- n warehouses
- n railway stations

is the result of our globalisation.

Therefore the associated plugs and sockets are internationally standardised according to IEC 309-2/EN 60 309-2.

This includes:

- n Plugs and sockets
3-pole + \ominus 3 h, 400-440 V
- n Nickel-plated contacts
- n Highly heat resistant contact carriers
- n Protection degree IP 67



Material Properties

Protection degrees

Chemical resistance:

	PC/ABS	Polyamide	Rubber	Polyethylene	Polystyrene	PBT at 23°C	PBT at 60°C	Stainless steel (V1.4301)
1. Hydrocarbons								
n-hexane	O	+	-	+	+	+	+	◇
four star petrol, containing aromatic chemicals	-	+	-	+	-	+	O	+
heating oil	O	+	O	+	O	+	+/O	+
gasoline f. cleaning purposes (free of aromatic chemicals)	O	+	O	O	O	+	O	+
benzol	-	+	-	+	-	+	-	+
naphtalene	-	+	-	+	O	+	O	◇
nitro benzol	-	+	-	O	-	O	O	◇
toluol	-	+	-	+	-	+	-	+
2. Alcohols								
ethyl alcohol, 96%	O	O	+	+	O	+	O	+
isopropanol	O	O	+	O	+	+	O	◇
phenol	-	-/Δ	-	+	O	-/Δ	-/Δ	O
glykol	O	O/Δ	+	+	+	O	-	◇
glycerine	O	+	+	+	+	+	+	+
3. Ketones								
acetone	-	+	+	+	-	+	-	+
methyl isobutyl cetone	-	+	-	O	-	+	O	◇
4. Acids (max. concentration)								
hydrochloric acid (20%)	+	-	O	+	+	O	-	-
nitric acid (10%)	+	-	O	O	O	+	O	+
phosphoric acid (30%)	+	-	+	+	+	+	O	+
sulfuric acid (30%)	+	-	+	+	+	O	-	O
citric acid (10%)	+	+	+	+	+	+	O	+
lactic acid (10%)	+	+	+	+	+	+	+	+
acetic acid (10%)	+	O	-	+	+	+	O	+
oleic acid	-	+	-	+	+	+	O	O
5. Bases								
aniline	-	O	-	+	-	O	-	+
sodium hydroxide (10%)	-	+	+	+	+	O	-	◇
ammonia solution, diluted	-	+	+	+	+	O	-	+
6. Halogenes								
bromine	-	-	-	-	-	◇	◇	-
chlorine	-	-	-	-	-	◇	◇	O
iodine	-	-	+	+	O	◇	◇	O
7. Oils, greases								
soybean oil	-	+	-	+	+	+	+	+
olive oil	-	+	-	+	+	+	+	+
lard	-	+	-	+	+	+	+	+
butter	-	+	-	+	+	+	+	+
8. Salt solutions								
potassium carbonate, saturated	-	+	+	O	+	+	O	+
sodium thiosulfate	+	+	+	+	+	+	O	+
sodium hypochloride	+	-	-	O	+	+	+	O
sea water	+	+	+	+/O	+	+	+	+
9. Detergents								
curd soap solution, 2%	+	+	O	+	+	+	+	+
washing powder, e.g. "Persil"	O	+	+	+	+	+	+	+
cleaning agent, e.g. "Dor"	+	+	O	+/O	+	◇	◇	+
10. Other media								
diethyl ether	-	+	-	+	-	+	O	◇
urea	+	O	+	+	+	◇	◇	+
trichloric ethylene	-	O	-	+	-	O	-	+
hydrogen superoxide, 30	+	O	-	O	+	+	O	O

- + = resistant
- O = resistant to a limited extent
- = not resistant
- Δ = soluble
- ◇ = no test results available yet

IEC/EN 60 529, VDE 0470 T1:

The type of protection is indicated by the IP code.
IP = International Protection

Component Code letters	Digits or letters IP	Meaning for the protection of operational equipment	Meaning for the protection of persons
First digit	0	Protection against ingress of solid foreign objects	Against access to dangerous parts with:
	1	(not protected)	(not protected)
	2	≥ 50 mm diameter	back of the hand
	3	≥ 2,5 mm diameter	finger
	4	≥ 1,0 mm diameter	tool
	5	dust protected	wire
Second digit	6	dust proof	wire
	0	Protection against harmful effects due to the ingress of water	
	1	(not protected)	
	2	vertically dripping water	
	3	dripping (15° angle)	
	4	spray water	
	5	splash water	
	6	water jets	
7	powerful water jets		
8	temporary immersion		
		continuous immersion	

Source: IEC/EN 60 529, VDE 0470 T1

Note:

According to the standard IEC/EN 60 309, CEEtyp plugs and sockets have the following **protection degrees**:

16 - 63 A: IP 44 and IP 67

125 A: only IP 67

CEE clock

Voltage systems with voltages over 50 V must have an earthing contact. The earthing contact, the phases and a neutral - if any - are arranged in a circle. The earthing contact has the largest diameter.

The diameter of the earthing contact is dimensioned in a way to prevent insertion into the insulated through holes of the phases and a possibly available neutral contact.

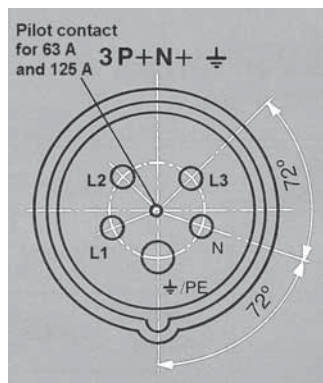

Arrangement of contact sleeves and terminal markings at 6 h position

The earth contact sleeve has the shortest distance to the plugging surface. Thus the protective earth connection is pre-mating to the voltage-carrying contacts when inserting a plug into a socket, and lagging when withdrawing the plug. Or, in other words, the earth contact makes first and breaks last.

Sockets have a keyway at 6 h position (when looking into the socket from the front).

The position of the earth contact sleeve in relation to this keyway indicates the coded voltage. The coded voltage may only be pre-set by the manufacturer. Furthermore it must not be possible to install a plug insert into a socket or a coupler.

WALTHER CEE clock

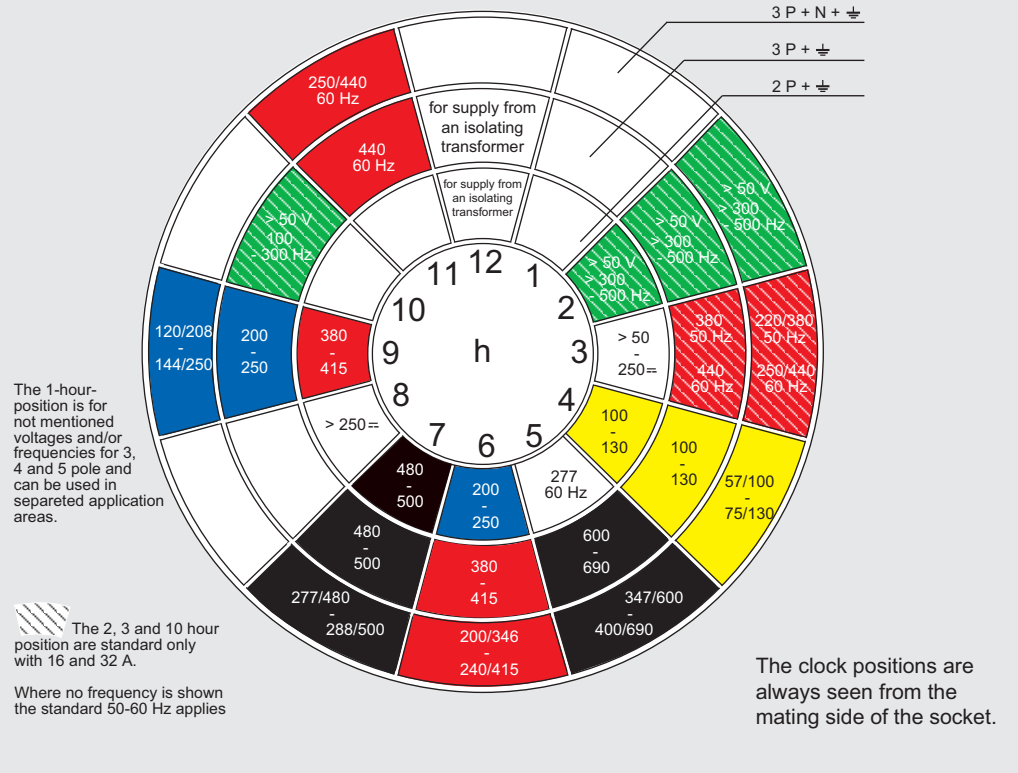

If the earthing-contact-coded voltage is colour-coded, then the colours as indicated in IEC/EN 60 309-1, table 2, have to be used.

Rated operating voltage V	Colour
20 to 25	violet
40 to 50	white
100 to 130	yellow
200 to 250	blue
380 to 480	red
500 to 690	black

Source: IEC/EN 60 309-1, table 2

1) For frequencies over 60 Hz up to 500 Hz, the colour green may - if necessary - also be used in connection with the code for the nominal operating voltage.

2) In countries where devices of series II are used, the colour orange is reserved for 125/250 V~ AC and the grey is reserved for 277 V~ AC.

Walther CEE clock acc. to IEC 309-2 and UL 1686

(clock positions seen from the mating side of the socket)

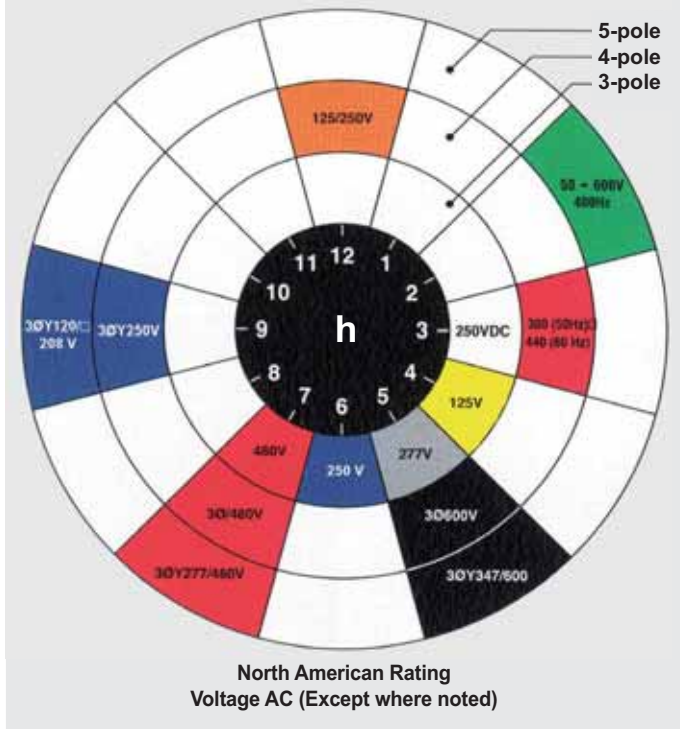

EC CERTIFICATE OF CONFORMITY

The manufacturer

WALTHER-WERKE
Ferdinand Walther GmbH
Ramsener Straße 6
67304 Eisenberg

herewith declares at his own responsibility that the below listed products

- CEEtyp plugs and sockets incl. switched and interlocked sockets
- CEEtyp socket outlet combinations

comply with the essential requirements of the following EC guidelines:

- low voltage directive 2006/95/EC

Applied standards and technical specifications:

- DIN EN 60309 part 1
- DIN EN 60309 part 2
- DIN EN 60439 part 1
- DIN VDE 0100, part 550

Eisenberg, 28.03.2012

WALTHER-WERKE
Ferdinand Walther GmbH



Sales Department



Quality Management

Customer:
Customer No.:
Order No.:
Part No.:

CONFIRMATION

We herewith declare that neither our product series CEEtyp nor Procon nor our "e-mobility" charging devices contain any substances nor exceed the limit values according to the Directive 2002/95/EC on the restriction of the use of certain hazardous substances in electrical and electronic equipment (RoHS), which are prohibited or restricted.

Our products are not affected by the amendments to the RoHS Directive dated 01.07.2008.

Our product series are not concerned by the Directive 2002/96/EC on waste electrical or electronic equipment (WEEE).

Our product series CEEtyp is only concerned by Directive 2002/96/EC (WEEE) for application in categories 1 – 8, but in relation herewith it is not considered as a device as defined by the Directive.

The present declaration has been issued on the base of the currently valid laws and regulations as well as to our best knowledge and to our current state of information. We recommend the addressee or the recipient of this declaration to ask for updates in regular intervals.

The present declaration replaces all previous declarations regarding this issue and it is valid for goods produced from January 2005 on.

Best regards

WALTHER-WERKE
Ferdinand Walther GmbH



Jürgen Kalthoff

Eisenberg, 28.03.2012

EC Declaration of Conformity

regarding directive 2006/122/EG (**PFOS** and **PAK**) and 1907/2006 (**REACH**)

The manufacturer

WALTHER-WERKE
Ferdinand Walther GmbH
Ramsener Straße 6
67304 Eisenberg

declares that the products that have been delivered to you:

CEEtyp plugs and sockets including switched sockets
CEEtyp socket combinations
AutoboxX consumer boxes
PROCON heavy duty connectors
CEPro plugs and sockets for power and control signals
EIBoxX automation technique
Assemblies for construction sites and other distributors for outside areas

do – to the best of our knowledge – not contain any substances in concentrations whose bringing into circulation is prohibited according to the directives pertaining to these products.

All information is given to the best of our knowledge and belief. It complies with the current state of technology. This statement is no legally bound guarantee.

We hope to have answered your questions to your complete satisfaction and are at your disposal in case you should have any further queries.

Eisenberg, 28.03.2012

WALTHER-WERKE
Ferdinand Walther GmbH

Sales Department

Quality Assurance

Customer :
Customer no. :
Order no. :
Part no. :

General Conditions

for the supply of products and services of the Electrical and Electronical Industry for Export

I. GENERAL

- The scope of deliveries and/or services (hereinafter referred to as „Supplies“) shall be determined by the written declarations of both Parties. General terms and conditions of the Purchaser shall apply only if and when expressly accepted by the supplier or the provider of services (hereinafter referred to as „Supplier“) in writing. Verbal agreements are only binding with a written confirmation by us.
- The Supplier herewith reserves any industrial property rights and/or copyrights pertaining to its cost estimates, drawings and other documents (hereinafter referred to as „Documents“). The Documents shall not be made accessible to third parties without the Supplier's prior consent and shall, upon request, be returned without undue delay to the Supplier if the contract is not awarded to the Supplier. Sentences 1 and 2 shall apply mutatis mutandis to documents of the Purchaser; these may, however, be made accessible to third parties to whom the Supplier may rightfully transfer Supplies.
- The Purchaser shall have the non-exclusive right to use standard software, provided that it remains unchanged, is used within the agreed performance parameters, and on the agreed equipment. The Purchaser may make one back-up copy without express agreement.
- Partial Supplies shall be allowed, unless they are unreasonable to accept for the Purchaser.

II. PRICES AND TERMS OF PAYMENT

- Prices indicated in the trade price list are gross prices per unit in EURO ex works and exclude packaging; value added tax shall be added at the then applicable rate. We reserve the right to invoice prices as valid on the day of shipment.
- Packaging will be charged at cost. Reusable boxes, frames etc. will be credited at two thirds of the invoiced amount by us in case of carriage paid return. According to law the German Supplier is associated with a packaging re-using system on the territory of the Federal Republic of Germany which disposes the packaging at the location of the commercial enterprises, agencies, manufacturers and craftsmen of the German electrical industry. The name of the disposal association is indicated on the packaging. The disposal system can be used by the German Purchaser. The Purchaser gets information on this system from the supplier.
- Delivery dates will be fixed to the best knowledge, but are without guarantee. Any claims due to delays in delivery will not be accepted.
- Payments have to be made in EURO within 30 days net after date of the invoice free at Supplier's paying office. For payments within 10 days we grant 3 % cash discount on the net value. Bank charges, especially for payments from foreign countries, have to be paid by the customer.
- The Purchaser may set off only those claims that are undisputed or against which no legal recourse is possible.

III. RETENTION OF TITLE

- Items pertaining to the Supplies („Retained Goods“) shall remain the property of the Supplier until each and every claim the Supplier has against the Purchaser on account of the business connection has been fulfilled. If the combined value of the security interests of the Supplier exceeds the value of all secured claims by more than 20 %, the Supplier shall release a corresponding part of the security interest if so requested by the Purchaser.
- For the duration of the retention of title, the Purchaser may not pledge the Retained Goods or use them as security, and resale shall be possible only for resellers in the ordinary course of their business and only on condition that the reseller receives payment from its customer or makes the transfer of property to the customer dependent upon the customer fulfilling its obligation to effect payment.
- The Purchaser shall inform the Supplier forthwith of any seizure or other act of intervention by third parties.
- Where the Purchaser fails to fulfill its duties, including failure to make payments due, the Supplier shall be entitled to cancel the contract and take back the Retained Goods in the case of continued failure following expiry of a reasonable time set by the Supplier; the statutory provisions that a time limit is not needed remain unaffected. The Purchaser shall be obliged to surrender the Retained Goods.

IV. TIME FOR SUPPLIES; DELAY

- Times set for Supplies can only be observed if all Documents to be supplied by the Purchaser, necessary permits and releases, especially concerning plans, are received in time and if agreed terms of payment and other obligations of the Purchaser are fulfilled. Unless these conditions are fulfilled in time, times set shall be extended appropriately; this shall not apply where the Supplier is responsible for the delay.
- If non-observance of the times set is due to force majeure such as mobilization, war, rebellion or similar events, e. g. strike or lockout, such time shall be extended accordingly.
- If the Supplier is responsible for the delay (hereinafter referred to as „Delay“) and the Purchaser demonstrably suffered a loss therefrom, the Purchaser may claim a compensation as liquidated damages of 0.5 % for every completed week of Delay, but in no case more than a total of 5 % of the price of that part of the Supplies which because of the Delay could not be put to the intended use.
- Purchaser's claims for damages due to delayed Supplies as well as claims for damages in lieu of performance exceeding the limits specified in No. 3 above shall be excluded in all cases of delayed Supplies even upon expiry of a time set to the Supplier to effect the Supplies. This shall not apply in cases of mandatory liability based on intent, gross negligence, or due to injury of life, body or health. Cancellation of the contract by the Purchaser based on statute shall be limited to cases where the Supplier is responsible for the delay. The above provisions do not imply a change in the burden of proof to the detriment of the Purchaser.
- At the Supplier's request the Purchaser shall declare within a reasonable period of time whether the Purchaser cancels the contract due to the delayed Supplies or insists on the Supplies to be carried out.
- If dispatch or shipment is delayed at the Purchaser's request by more than one month after notice of the readiness for dispatch was given, the Purchaser may be charged, for every month commenced, storage costs of 0.5 % of the price of the items of the Supplies, but in no case more than a total of 5 %. The parties to the contract may prove that higher or, as the case may be, lower storage costs have been incurred.

V. TRANSFER OF RISK

- Even where delivery has been agreed freight free, the risk shall pass to the Purchaser as follows:
 - if the Supplies do not include assembly or erection, at the time when the Supplies are shipped or picked up by the carrier. Upon request of the Purchaser, the Supplier shall insure the Supplies against the usual risks of transport at the expense of the Purchaser;
 - if the Supplies include assembly or erection, at the day of taking over in the own works or, if so agreed, after a fault-free trial run.
- The risk shall pass to the Purchaser if dispatch, shipping, the start or performance of assembly or erection, the taking over in the own works or the trial run is delayed for reasons for which the Purchaser is responsible or if the Purchaser has otherwise failed to accept the Supplies.

VI. SPECIAL VERSIONS

CEEtyp socket outlet combinations, assemblies for construction sites, distribution ACS for festival grounds and market places as well as transformer compact stations are special versions according to customer's requirements. Taking back is not possible.

VII. RECEIVING OF SUPPLIES

The Purchaser shall not refuse to receive Supplies due to minor defects.

VIII. DEFECTS AS TO QUALITY

- The Supplier shall be liable for defects as to quality („Sachmängel“, hereinafter referred to as „Defects“), as follows:
- All parts or services where a Defect becomes apparent within the limitation period shall, at the discretion of the Supplier, be repaired, replaced or provided again free of charge irrespective of the hours of operation elapsed, provided that the reason for the Defect had already existed at the time when the risk passed.
 - Claims based on Defects are subject to a limitation period of 12 months. This provision shall not apply where longer periods are prescribed by law according to Sec. 438 para. 1 No. 2 (buildings and things used for a building), Sec. 479 para. 1 (right of recourse), and Sec. 634a para. 1 No. 2 (defects of a building) German Civil Code („BGB“), as well as in cases of injury of life, body or health, or where the Supplier intentionally or grossly negligently fails to fulfill its obligation or fraudulently conceals a Defect. The legal provisions regarding suspension of expiration („*Ablaufhemmung*“), suspension („*Hemmung*“) and recommencement of limitation periods remain unaffected.
 - The Purchaser shall notify Defects to the Supplier in writing and without undue delay.
 - In the case of notification of a Defect, the Purchaser may withhold payments to a reasonable extent taking into account the Defect occurred. The Purchaser, however, may withhold payments only if the subject-matter of the notification of the Defect occurred is justified beyond doubt. Unjustified notifications of Defect shall entitle the Supplier to have its expenses reimbursed by the Purchaser.
 - The Supplier shall first be given the opportunity to supplement its performance („*Nacherfüllung*“) within a reasonable period of time.
 - If supplementary performance is unsuccessful, the Purchaser shall be entitled to cancel the contract or reduce the remuneration, irrespective of any claims for damages it may have according to Art. XI.
 - There shall be no claims based on Defect in cases of insignificant deviations from the agreed quality, of only minor impairment of usefulness, of natural wear and tear or damage arising after the transfer of risk from faulty or negligent handling, excessive strain, unsuitable equipment, defective workmanship, inappropriate foundation soil or from particular external influences not assumed under the contract, or from non-reproducible software errors. Claims based on defects attributable to improper modifications or repair work carried out by the Purchaser or third parties and the consequences thereof shall be likewise excluded.
 - The Purchaser shall have no claim with respect to expenses incurred in the course of supplementary performance, including costs of travel and transport, labour, and material, to the extent that expenses are increased because the subject-matter of the Supplies was subsequently brought to another location than the Purchaser's branch office, unless doing so complies with the intended use of the Supplies.
 - The Purchaser's right of recourse against the Supplier pursuant to Sec. 478 BGB is limited to cases where the Purchaser has not concluded an agreement with its customers exceeding the scope of the statutory provisions governing claims based on Defects. Moreover, No. 8 above shall apply mutatis mutandis to the scope of the right of recourse the Purchaser has against the Supplier pursuant to Sec. 478 para. 2 BGB.
 - Furthermore, the provisions of Art. XI (Other Claims for Damages) shall apply in respect of claims of damages. Any other claims of the Purchaser against the Supplier or its agents or any such claims exceeding the claims provided for in this Art. VIII, based on a Defect, shall be excluded.

IX. INDUSTRIAL PROPERTY RIGHTS AND COPYRIGHT; DEFECTS IN TITLE

- Unless otherwise agreed, the Supplier shall provide the Supplies free from third parties' industrial property rights and copyrights (hereinafter referred to as „IPR“) with respect to the country of the place of destination. If a third party asserts a justified claim against the Purchaser based on an infringement of an IPR with respect to the Supplies made by the Supplier and then used in conformity with the contract, the Supplier shall be liable to the Purchaser within the time period stipulated in Art. VIII No. 2 as follows:
 - The Supplier shall choose whether to acquire, at its own expense, the right to use the IPR with respect to the Supplies concerned or whether to modify the Supplies such that they no longer infringe the IPR or replace them. If this would be unreasonable to demand from the Supplier, the Purchaser may cancel the contract or reduce the remuneration pursuant to the applicable statutory provisions.
 - The Supplier's liability to pay damages shall be governed by Art. XI.
 - The above obligations of the Supplier shall only apply if the Purchaser (i) immediately notifies the Supplier of any such claim asserted by the third party in writing, (ii) does not concede the existence of an infringement and (iii) leaves any protective measures and settlement negotiations to the discretion of the Supplier. If the Purchaser stops using the Supplies in order to reduce the damage or for other good reason, it shall be obliged to point out to the third party that no acknowledgement of the alleged infringement may be inferred from the fact that the use has been discontinued.
- Claims of the Purchaser shall be excluded if it is itself responsible for the infringement of an IPR.
- Claims of the Purchaser shall also be excluded if the infringement of the IPR is caused by specifications made by the Purchaser, to a type of use not foreseeable by the Supplier or to the Supplies being modified by the Purchaser or being used together with products not provided by the Supplier.
- In addition, with respect to claims by the Purchaser pursuant to No. 1 a) above, Art. VIII Nos. 4, 5, and 9 shall apply mutatis mutandis in the event of an infringement of an IPR.
- Where other defects in title occur, Art. VIII shall apply mutatis mutandis.
- Any other claims of the Purchaser against the Supplier or its agents or any such claims exceeding the claims provided for in this Art. IX, based on a defect in title, shall be excluded.

X. IMPOSSIBILITY OF PERFORMANCE; ADAPTATION OF CONTRACT

- To the extent that Supplies are impossible to be carried out, the Purchaser shall be entitled to claim damages, unless the Supplier is not responsible for the impossibility. The Purchaser's claim for damages shall, however, be limited to an amount of 10 % of the value of the part of the Supplies which, owing to the impossibility, cannot be put to the intended use. This limitation shall not apply in the case of mandatory liability based on intent, gross negligence or injury of life, body or health; this does not imply a change in the burden of proof to the detriment of the Purchaser. The right of the Purchaser to cancel the contract shall remain unaffected.
- Where unforeseeable events within the meaning of Art. IV No. 2 substantially change the economic importance or the contents of the Supplies or considerably affect the Supplier's business, the contract shall be adapted taking into account the principles of reasonableness and good faith. Where doing so is economically unreasonable, the Supplier shall have the right to cancel the contract. If the Supplier intends to exercise its right to cancel the contract, it shall notify the Purchaser thereof without undue delay after having realised the repercussions of the event; this shall also apply even where an extension of the delivery period had previously been agreed with the Purchaser.

XI. OTHER CLAIMS FOR DAMAGES

- Any claims for damages and reimbursement of expenses the Purchaser may have (hereinafter referred to as „Claims for Damages“), based on whatever legal reason, including infringement of duties arising in connection with the contract or tort, shall be excluded.
- The above shall not apply in the case of mandatory liability, e. g. under the German Product Liability Act („*Produkthaftungsgesetz*“), in the case of intent, gross negligence, injury of life, body or health, or breach of a condition which goes to the root of the contract („*wesentliche Vertragspflichten*“). However, Claims for Damages arising from a breach of a condition which goes to the root of the contract shall be limited to the foreseeable damage which is intrinsic to the contract, unless caused by intent or gross negligence or based on liability for injury of life, body or health. The above provision does not imply a change in the burden of proof to the detriment of the Purchaser.
- To the extent that the Purchaser has a valid Claim for Damages according to this Art. XI, it shall be time-barred upon expiration of the limitation period applicable to Defects pursuant to Art. VIII No. 2. In the case of claims for damages under the German Product Liability Act, the statutory provisions governing limitation periods shall apply.

XII. VENUE AND APPLICABLE LAW

- If the Purchaser is a businessperson, sole venue for all disputes arising directly or indirectly out of the contract is Rockenhausen. However, the Supplier may also bring an action at the Purchaser's place of business.
- Legal relations existing in connection with this contract shall be governed by German substantive law, to the exclusion of the United Nations Convention on Contracts for the International Sale of Goods (CISG).

XIII. SEVERABILITY CLAUSE

The legal invalidity of one or more provisions of this contract shall in no way affect the validity of the remaining provisions. This shall not apply if it would be unreasonable for one of the parties to continue the contract.



Walther-Werke
Ferdinand Walther GmbH
Ramsener Straße 6
67304 Eisenberg/Pfalz
Phone + (49) 63 51 / 475-0
Fax + (49) 63 51 / 475-227
www.walther-werke.de
mail@walther-werke.de